

Test Report

Applicant: Tescom Elektronik Sanayi ve Ticaret A.S.

Product Name: UPS

Brand Name: TESCOM

Model No.: LEO+ 650VA , LEO+ 850VA

Remark: Provision is made on the basis of the original report, MTEC21010076 basis; Changed applicant, manufacturer, trademark and model.

Date of Receipt : Apr.07, 2021

Date of Test: Jul. 19- 28, 2016

Date of Report: Apr.08, 2021

Prepared by: Shenzhen Most Technology Service Co., Ltd.

The EMC testing has been performed on the submitted samples and found in compliance with the council EMC directive 2014/30/EU.

Shenzhen Most Technology Service Co., Ltd.
No.5, 2nd Langshan Road, North District, Hi-tech Industry Park,
Nanshan, Shenzhen, Guangdong, China
Phone: 86-755-86026850
Fax: 86-755-26013350
[http:// www.szmost.com](http://www.szmost.com)

TABLE OF CONTENTS

Description	Page
Test Report Declaration.....	4
1. GENERAL INFORMATION	5
1.1. Description of Device (EUT).....	5
1.2. Operational Mode(s) of EUT	5
1.3. Test Voltage(s) of EUT	5
2. DESCRIPTION OF TEST STANDARD	6
3. LABORATORY INFORMATION.....	7
3.1. Laboratory Name	7
3.2. Location	7
3.3. Test facility	7
3.4. Measurement Uncertainty	7
4. SUMMARY OF TEST RESULTS.....	8
5. BLOCK DIAGRAM OF TEST SETUP.....	9
5.1. Block Diagram of connection between EUT and simulation-EMI.....	9
5.2. Block Diagram of connection between EUT and simulation-EMS	9
6. TEST INSTRUMENT USED	10
6.1. For Conducted Disturbance at Mains Terminals Emission Test.....	10
6.2. For Radiation Test (In Anechoic Chamber).....	10
6.3. For Harmonic / Flicker Test.....	10
6.4. For Electrostatic Discharge Immunity Test	10
6.5. For RF Strength Susceptibility Test	10
6.6. For Electrical Fast Transient/Burst Immunity Test	11
6.7. For Surge Test.....	11
6.8. For Injected Currents Susceptibility Test	11
6.9. For Magnetic Field Immunity Test.....	11
6.10. For Voltage Dips and Interruptions Test	11
7. CONDUCTED DISTURBANCE AT MAINS TERMINALS TEST.....	12
7.1. Configuration of Test System	12
7.2. Test Standard	12
7.3. Power Line Conducted Disturbance at Mains Terminals Limit	12
7.4. Test Procedure	12
7.5. Conducted Disturbance at Mains Terminals Test Results	13
8. RADIATED DISTURBANCE TEST	14
8.1. Configuration of Test System.....	14
8.2. Test Standard	14
8.3. Radiated Disturbance Limit.....	14
8.4. Test Procedure	14
8.5. Radiated Disturbance Test Results	15
9. HARMONIC CURRENT TEST	16
9.1. Configuration of Test System.....	16
9.2. Test Standard	16
9.3. Test Limits	16
9.4. Test Results.....	16
10. IMMUNITY PERFORMANCE CRITERIA.....	19
11. LOW FREQUENCY SIGNALS TEST	20
11.1. Configuration of Test System.....	20
11.2. Test Standard	20
11.3. Test Results.....	20
12. ELECTROSTATIC DISCHARGE IMMUNITY TEST	22

12.1.	Configuration of Test System	22
12.2.	Test Standard	22
12.3.	Severity Levels and Performance Criterion	23
12.4.	Test Procedure	23
12.5.	Test Results	23
13.	RF FIELD STRENGTH SUSCEPTIBILITY TEST.....	25
13.1.	Configuration of Test System	25
13.2.	Test Standard	25
13.3.	Severity Levels and Performance Criterion	25
13.4.	Test Procedure	26
13.5.	Test Results	26
14.	ELECTRICAL FAST TRANSIENT/BURST IMMUNITY TEST	28
14.1.	Configuration of Test System	28
14.2.	Test Standard	28
14.3.	Severity Levels and Performance Criterion	28
14.4.	Test Procedure	29
14.5.	Test Results	29
15.	SURGE TEST	31
15.1.	Configuration of Test System	31
15.2.	Test Standard	31
15.3.	Severity Levels and Performance Criterion	31
15.4.	Test Procedure	32
15.5.	Test Results	32
16.	INJECTED CURRENTS SUSCEPTIBILITY TEST	34
16.1.	Configuration of Test System	34
16.2.	Test Standard	34
16.3.	Severity Levels and Performance Criterion	34
16.4.	Test Procedure	34
16.5.	Test Results	35
17.	MAGNETIC FIELD IMMUNITY TEST	37
17.1.	Configuration of Test System	37
17.2.	Test Standard	37
17.3.	Severity Levels and Performance Criterion	37
17.4.	Test Procedure	38
17.5.	Test Results	38
18.	VOLTAGE DIPS AND INTERRUPTIONS TEST.....	40
18.1.	Configuration of Test System	40
18.2.	Test Standard	40
18.3.	Severity Levels and Performance Criterion	40
18.4.	Test Procedure	41
18.5.	Test Results	41
APPENDIX I		(8 pages)
APPENDIX II		(12 pages)
APPENDIX III (Photos of the EUT)		(8 Pages)

TEST REPORT DECLARATION

Report Number	MTEC21040585	
Applicant	Tescom Elektronik Sanayi ve Ticaret A.S.	
	Merkez: Dudullu OSB 2.Cadde No:7 Umraniye, Istanbul / TURKEY	
Manufacturer	EAST Group Co., Ltd.	
	No.6 Northern Industry Road, Songshan Lake Sci. & Tech. Industrial Park, Dongguan City, Guangdong Province, China	
Product	Product Name	UPS
	Model No.	LEO+ 650VA , LEO+ 850VA
	Power Supply	AC220-240V,50/60Hz DC12V(by Battery)
Test Result	The EUT was found compliant with the requirement(s) of the standards.	
Standard	EN IEC 62040-2:2018, EN IEC 61000-3-2:2019 (IEC 61000-2-2:2002+A1:2017+A2:2018 ,IEC 61000-4-2:2008, IEC 61000-4-3:2006, IEC 61000-4-4:2012, IEC 61000-4-5:2014, IEC 61000-4-6:2013, IEC 61000-4-8:2009, IEC 61000-4-11:2004)	
*Note	<p>The above device has been tested by Shenzhen Most Technology Service Co., Ltd. To determine the maximum emission levels emanating from the device and the severe levels of the device can endure and its performance criterion. The test record, data evaluation & Equipment Under Test (EUT) configurations represented are contained in this test report and Shenzhen Most Technology Service Co., Ltd. Is assumed full responsibility for the accuracy and completeness of test. Also, this report shows that the EUT is technically compliant with the requirement of the above standards.</p> <p>This report applies to above tested sample only. This report shall not be reproduced except in full, without written approval of Shenzhen Most Technology Service Co., Ltd., this document may be altered or revised by Shenzhen Most Technology Service Co., Ltd., personal only, and shall be noted in the revision of the document.</p>	
Prepared by		
	Alisa Luo(Engineer)	
Reviewed by		
	Sunny Deng(Engineer)	
Approved by		
	Yvette Zhou(Manager)	

1. GENERAL INFORMATION

1.1. Description of Device (EUT)

Description	:	UPS
Model Number	:	LEO+ 650VA , LEO+ 850VA
Remark	:	N/A

1.2. Operational Mode(s) of EUT

Order Number	:	Test Mode(s)
1	:	Charging
2	:	Charging+Discharging
3	:	Discharging

1.3. Test Voltage(s) of EUT

Order Number	:	Test Voltage(s)
1	:	AC 230V/50Hz
2	:	DC 12V by Battery

2. DESCRIPTION OF TEST STANDARD

The intention of this publication is to establish uniform requirements for the radio disturbance level of the equipment contained in the scope, to fix limits of disturbance, to describe methods of measurement and to standardize operating conditions and interpretation of results.

The following referenced standard are indispensable for the application of this report.

Referenced Description below:

EN IEC 62040-2:2018

Uninterruptible power systems(UPS)-Part2:Electromagnetic compatibility(EMC)requirements

EN IEC 61000-3-2:2019

Limits for harmonic current emissions (equipment input current ≤ 16 A per phase).

3. LABORATORY INFORMATION

3.1. Laboratory Name

Shenzhen Most Technology Service Co., Ltd.

3.2. Location

No.5, 2nd Langshan Road, North District, Hi-tech Industrial Park, Nanshan, Shenzhen, Guangdong, China

3.3. Test facility

- 3m Anechoic Chamber : Nov. 28, 2012 File on Federal Communication Commission
Registration Number:490827
- Shielding Room : Nov. 28, 2012 File on Federal Communication Commission
Registration Number:490827
- EMC Lab. : Accredited by TUV Rheinland Shenzhen
Audit Report: UA 50149851
Mar. 12, 2009
- Accredited by Industry Canada
Registration Number: 7103A-1
Oct. 22, 2012
- Accredited by TIMCO
Registration Number: Q1460
March 28, 2010

3.4. Measurement Uncertainty

No.	Item	Uncertainty
1.	Uncertainty for Conducted Disturbance Test	1.25dB
2.	Uncertainty for Radiated Disturbance Test	3.15dB

4. SUMMARY OF TEST RESULTS

EMISSION			
Test Item	Standard	Limits	Results
Conducted disturbance at mains terminals	EN IEC 62040-2:2018	C1	PASS
Radiated disturbance	EN IEC 62040-2:2018	C1	PASS
Harmonic current emissions	EN IEC 61000-3-2:2019	Class A	PASS
IMMUNITY (EN IEC 62040-2:2018)			
Test Item	Basic Standard	Performance Criteria	Results
Low frequency signals	IEC 61000-2-2:2002+ A1:2017+A2:2018	A	PASS
Electrostatic discharge (ESD)	IEC 61000-4-2: 2008	B	PASS
Radio-frequency, Continuous radiated disturbance	IEC 61000-4-3:2006	A	PASS
Electrical fast transient (EFT)	IEC 61000-4-4:2012	B	PASS
Surge (Input a.c. power ports)	IEC 61000-4-5:2014	B	PASS
Radio-frequency, Continuous conducted disturbance	IEC 61000-4-6:2013	A	PASS
Power frequency magnetic field	IEC 61000-4-8:2009	A	PASS
Voltage dips, >95% reduction	IEC 61000-4-11:2004	B	PASS
Voltage dips, 30% reduction		B	PASS
Voltage interruptions		B	PASS
N/A is an abbreviation for Not Applicable.			

5. BLOCK DIAGRAM OF TEST SETUP

The equipments are installed test to meet EN 62040-2 requirement and operating in a manner which tends to maximize its emission characteristics in a normal application. EUT was tested in normal configuration (Please See following Block diagrams)

5.1. Block Diagram of connection between EUT and simulation-EMI



(EUT: UPS)

5.2. Block Diagram of connection between EUT and simulation-EMS



(EUT: UPS)

6. TEST INSTRUMENT USED

6.1. For Conducted Disturbance at Mains Terminals Emission Test

Item	Equipment	Manufacturer	Model No.	Serial No.	Last Cal.	Cal. Interval
1.	Test Receiver	Rohde & Schwarz	ESCI	100492	Mar. 10, 16	1 Year
2.	L.I.S.N.	Rohde & Schwarz	ENV216	100093	Mar. 10, 16	1 Year
3.	Coaxial Switch	Anritsu Corp	MP59B	6200283933	Mar. 10, 16	1 Year
4.	Terminator	Hubersuhner	50Ω	No.1	Mar. 10, 16	1 Year
5.	RF Cable	SchwarzBeck	N/A	No.1	Mar. 10, 16	1 Year

6.2. For Radiation Test (In Anechoic Chamber)

Item	Equipment	Manufacturer	Model No.	Serial No.	Last Cal.	Cal. Interval
1.	Test Receiver	Rohde & Schwarz	ESPI	101202	Mar. 10, 16	1 Year
2.	Bilog Antenna	Sunol	JB3	A121206	Mar. 10, 16	1 Year
3.	Cable	Resenberger	N/A	NO.1	Mar. 10, 16	1 Year
4.	Cable	SchwarzBeck	N/A	NO.2	Mar. 10, 16	1 Year
5.	Cable	SchwarzBeck	N/A	NO.3	Mar. 10, 16	1 Year
6.	DC Power Filter	DuoJi	DL2×30B	N/A	N/A	N/A
7.	Single Phase Power Line Filter	DuoJi	FNF 202B30	N/A	N/A	N/A
8.	3 Phase Power Line Filter	DuoJi	FNF 402B30	N/A	N/A	N/A

6.3. For Harmonic / Flicker Test

Item	Equipment	Manufacturer	Model No.	Serial No.	Last Cal.	Cal. Interval
	AC Power Source	Kikusui	AC40MA	LM003232	Mar. 10, 16	1 Year
2.	Test Analyzer	Kikusui	KHA1000	LM003720	Mar. 10, 16	1 Year
3.	Line Impedance Network	Kikusui	LIN40MA-PCR-L	LM002352	Mar. 10, 16	1 Year

6.4. For Electrostatic Discharge Immunity Test

Item	Equipment	Manufacturer	Model No.	Serial No.	Last Cal.	Cal. Interval
1.	ESD Tester	Zhongsheng	ESD-203AX	023K14538	Mar. 10, 16	1 Year

6.5. For RF Strength Susceptibility Test

Item	Equipment	Manufacturer	Model No.	Serial No.	Last Cal.	Cal. Interval
1.	Signal Generator	IFR	2032	203002/100	Mar. 10, 16	1 Year
2.	Amplifier	A&R	150W1000	301584	NCR	NCR

3.	Dual Directional Coupler	A&R	DC6080	301508	Mar. 10, 16	1 Year
4.	Power Sensor	Anritsu	MA2491A	32263	Mar. 10, 16	1 Year
5.	Power Meter	R&S	NRVS	100444	Mar. 10, 16	1 Year
6.	Field Monitor	A&R	FM5004	300329	Mar. 10, 16	1 Year
7.	Field Probe	A&R	FP5000	300221	Mar. 10, 16	1 Year
8.	Log-periodic Antenna	A&R	AT1080	16512	Mar. 10, 16	1 Year
9.	RF Cable	MIYAZAKI	N/A	No.1/No.2	Mar. 10, 16	1 Year

6.6. For Electrical Fast Transient/Burst Immunity Test

Item	Equipment	Manufacturer	Model No.	Serial No.	Last Cal.	Cal. Interval
1.	EMCPRO System	EM Test	UCS-500-M4	V0648102026	Mar. 10, 16	1 Year

6.7. For Surge Test

Item	Equipment	Manufacturer	Model No.	Serial No.	Last Cal.	Cal. Interval
1.	EMCPRO System	EM Test	UCS-500-M4	V0648102026	Mar. 10, 16	1 Year

6.8. For Injected Currents Susceptibility Test

Item	Equipment	Manufacturer	Model No.	Serial No.	Last Cal.	Cal. Interval
1.	Signal Generator	IFR	2032	203002/100	Mar. 10, 16	1 Year
2.	Amplifier	A&R	150W1000	301584	NCR	NCR
3.	CDN	FCC	FCC-801-M2-25	47	Mar. 10, 16	1 Year
4.	CDN	FCC	FCC-801-M3-25	107	Mar. 10, 16	1 Year
5.	EM Injection Clamp	FCC	F-203I-23mm	403	Mar. 10, 16	1 Year
6.	RF Cable	MIYAZAKI	N/A	No.1/No.2	Mar. 10, 16	1 Year

6.9. For Magnetic Field Immunity Test

Item	Equipment	Manufacturer	Model No.	Serial No.	Last Cal.	Cal. Interval
1.	EMCPRO System	EM Test	UCS-500-M4	V0648102026	Mar. 10, 16	1 Year

6.10. For Voltage Dips and Interruptions Test

Item	Equipment	Manufacturer	Model No.	Serial No.	Last Cal.	Cal. Interval
1.	EMCPRO System	EM Test	UCS-500-M4	V0648102026	Mar. 10, 16	1 Year

7. CONDUCTED DISTURBANCE AT MAINS TERMINALS TEST

7.1. Configuration of Test System

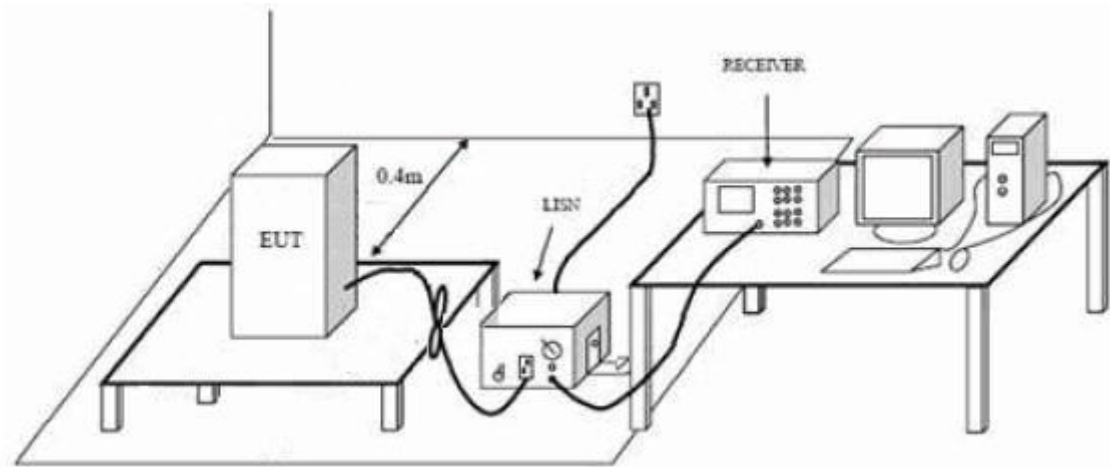

7.2. Test Standard

EN IEC 62040-2:2018

7.3. Power Line Conducted Disturbance at Mains Terminals Limit

Table 1 – Limits of mains terminal and network port disturbance voltage for category C1 and category C2 UPS in the frequency range 0,15 MHz to 30 MHz

Frequency range MHz	Limits dB (μ V)							
	Category C1 UPS				Category C2 UPS			
	Mains terminal		Network port		Mains terminal		Network port	
	Quasi-peak	Average	Quasi-peak	Average	Quasi-peak	Average	Quasi-peak	Average
0,15 to 0,50 ^b	66 to 56 ^a	56 to 46 ^a	84 to 74 ^a	74 to 64 ^a	79	66	97 to 87 ^a	84 to 74 ^a
0,50 to 5 ^b	56	46	74	64	73	60	87	74
5 to 30	60	50			73	60		

^a The limit decreases linearly with the logarithm of the frequency.
^b The lower limit shall apply at the transition frequency.

- Notes: 1. * Decreasing linearly with logarithm of frequency.
 2. The lower limit shall apply at the transition frequencies.

7.4. Test Procedure

The EUT was placed on a non-metallic table, 10cm above the ground plane. The EUT Power connected to the power mains through a line impedance stabilization network (L.I.S.N. 1#). This provided a 50-ohm coupling impedance for the EUT (Please refer to the block diagram of the test setup and photographs). The other peripheral devices power cord connected to the power mains through a line impedance stabilization network (L.I.S.N.#2). Both sides of power line were checked for maximum conducted interference. In order to find the maximum emission, the relative positions of equipments and all of the interface cables were changed according to EN 62040-2 on conducted Disturbance test.

The bandwidth of test receiver is set at 9kHz.

The frequency range from 150kHz to 30MHz is checked. The test result are reported on Section 7.5.

7.5. Conducted Disturbance at Mains Terminals Test Results

7.5.1. Test Results: **PASS**

7.5.2. If the average limit is met when using a quasi-peak detector, the EUT shall be deemed to meet both limits and measurement with average detector is unnecessary.

7.5.3. Emission Level = Correct Factor + Reading Level.

7.5.4. The test data and the scanning waveform are attached within Appendix I.

8. RADIATED DISTURBANCE TEST

8.1. Configuration of Test System

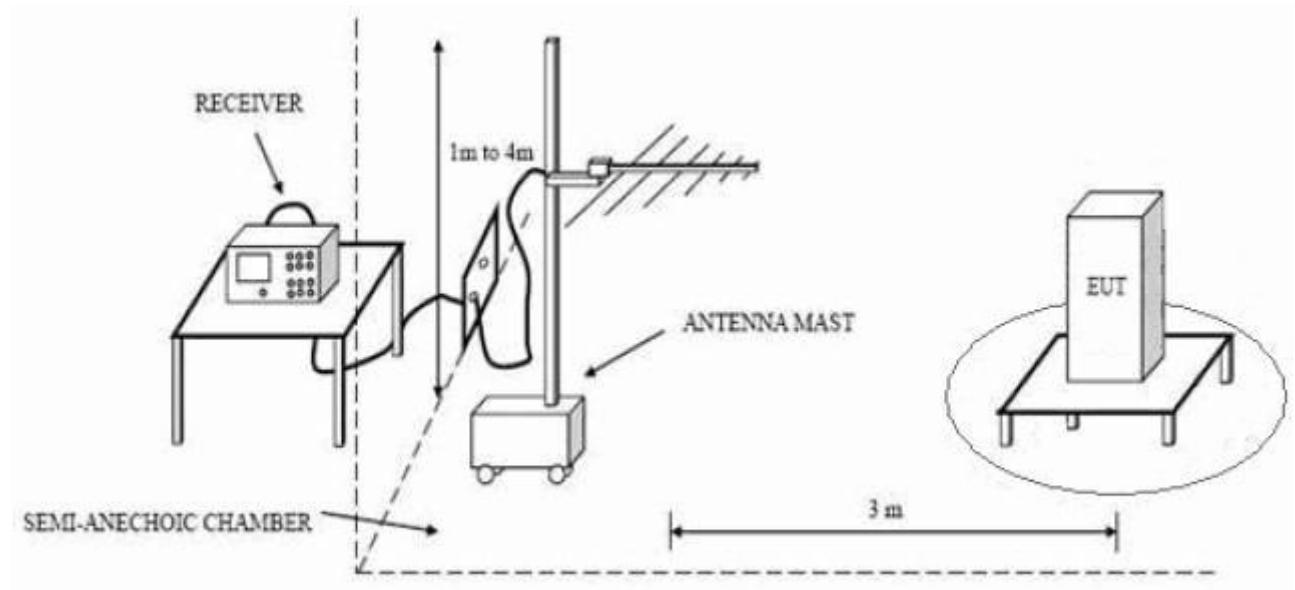

8.2. Test Standard

EN IEC 62040-2:2018

8.3. Radiated Disturbance Limit

Table 3 – Limits of radiated emission in the frequency range 30 MHz to 1 000 MHz

Frequency range MHz	Quasi-peak limits dB ($\mu\text{V}/\text{m}$)		
	Category C1 UPS	Category C2 UPS	Category C3 UPS
30 to 230 ^a	30	40	50
230 to 1 000	37	47	60

^a The lower limit shall apply at the transition frequency.

Note: 1. The lower limit shall apply at the transition frequencies.

2. Distance refers to the distance in meters between the test antenna and the closed point of any part of the EUT.

8.4. Test Procedure

The EUT was placed on a non-metallic table, 10 cm above the ground plane inside a semi-anechoic chamber. An antenna was located 10m from the EUT on an adjustable mast. A pre-scan was first performed in order to find prominent radiated emissions. For final emissions measurements at each frequency of interest, the EUT were rotated and the antenna height was varied between 1m and 4m in order to maximize the emission. Measurements in both horizontal and vertical polarities were made and the data was recorded. In order to find the maximum emission, the relative positions of equipments and all of the interface cables were changed according to EN60240-2 on Radiated Disturbance test.

The bandwidth setting on the test receiver is 120 kHz.

The frequency range from 30MHz to 1000MHz is checked. The test result are reported on Section 8.5.

8.5. Radiated Disturbance Test Results

8.5.1. Test Results: **PASS**

8.5.2. Emission Level= Correct Factor + Reading Level.

8.5.3. All reading are Quasi-Peak values.

8.5.4. The test data and the scanning waveform are attached within Appendix II.

9. HARMONIC CURRENT TEST

9.1. Configuration of Test System

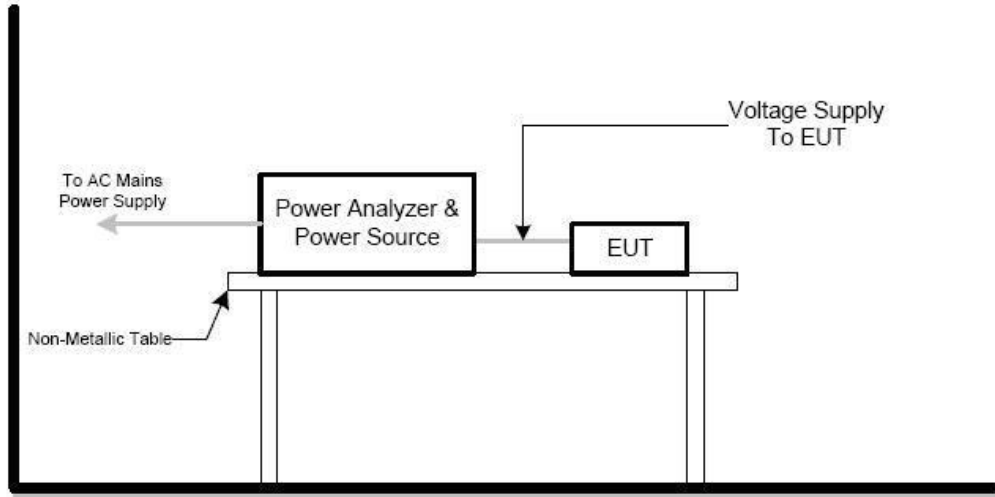

9.2. Test Standard

EN IEC 61000-3-2:2019; Class A

9.3. Test Limits

For Class A equipment, the harmonics of the input current shall not exceed the values given in below:

Harmonic order n	Maximum permissible Harmonic current A
Odd harmonics	
3	2.30
5	1.14
7	0.77
9	0.40
11	0.33
13	0.21
$15 \leq n \leq 39$	$0.15 \frac{15}{n}$
Even harmonics	
2	1.08
4	0.43
6	0.30
$8 \leq n \leq 40$	$0.23 \frac{8}{n}$

9.4. Test Results

9.4.1. Test Results: PASS

HARMONICS CURRENT TEST REPORT

Company	Tescom	Test Engineer	SUNNY
Model name	UPS		
Type	LEO+ 650VA		
Serial No.		Type of test	EN IEC 61000-3-2:2019 *IEC61000-3-2: 2014
Operating mode	Charging+Discharging		EN61000-4-7: 2002/A1:2009 *IEC61000-4-7: 2002+A1:2008
Date of test	2016/07/22 12:01:36	Classification	Class A
Climatic condition	T:26;H:53%	Power analyzer	KHA1000, Ver1.50
Memo		Supply Source	AC 230V/50Hz
		Reference Impedance	

Test Data of Current Harmonics

FINAL TEST RESULT **PASS**

Voltage	230.32V	THC	0.168A
Current	1.510A	POHC/LIMIT	0.009A/ -----A *4
Power	344.32W	Nominal	230V/ 50Hz
Apparent Power	347.7VA	Fundamental current	1.495A
		Measuring period	150s
		Margin	100%

HarmOrder	Limit1(A rms)	Limit2(A rms)	Ave(A rms)	Max(A rms)	LimitOver(s)	Judge
2	1.0800	2.1600	0.1107	0.112	0.0	Pass
3	2.3000	4.6000	0.1089	0.111	0.0	Pass
4	0.4300	0.8600	0.0423	0.043	0.0	Pass
5	1.1400	2.2800	0.0297	0.031	0.0	Pass
6	0.3000	0.6000	0.0151	0.016	0.0	Pass
7	0.7700	1.5400	0.0120	0.013	0.0	Pass
8	0.2300	0.4600	0.0080	0.009	0.0	Pass
9	0.4000	0.8000	0.0100	0.011	0.0	Pass
10	0.1840	0.3680	0.0040	0.004	0.0	N/A
11	0.3300	0.6600	0.0060	0.006	0.0	N/A
12	0.1533	0.3066	0.0021	0.003	0.0	N/A
13	0.2100	0.4200	0.0017	0.002	0.0	N/A
14	0.1314	0.2628	0.0020	0.002	0.0	N/A
15	0.1500	0.3000	0.0050	0.005	0.0	N/A
16	0.1150	0.2300	0.0020	0.002	0.0	N/A
17	0.1324	0.2648	0.0060	0.006	0.0	N/A
18	0.1022	0.2044	0.0027	0.003	0.0	N/A
19	0.1184	0.2368	0.0050	0.005	0.0	N/A
20	0.0920	0.1840	0.0020	0.002	0.0	N/A
21	0.1071	0.2142	0.0040	0.004	0.0	N/A
22	0.0836	0.1672	0.0020	0.002	0.0	N/A
23	0.0978	0.1956	0.0050	0.005	0.0	N/A
24	0.0767	0.1534	0.0010	0.001	0.0	N/A
25	0.0900	0.1800	0.0030	0.003	0.0	N/A
26	0.0708	0.1416	0.0010	0.001	0.0	N/A
27	0.0833	0.1666	0.0010	0.001	0.0	N/A
28	0.0657	0.1314	0.0010	0.002	0.0	N/A
29	0.0776	0.1552	0.0021	0.003	0.0	N/A
30	0.0613	0.1226	0.0010	0.002	0.0	N/A
31	0.0726	0.1452	0.0020	0.002	0.0	N/A
32	0.0575	0.1150	0.0010	0.001	0.0	N/A
33	0.0682	0.1364	0.0010	0.001	0.0	N/A
34	0.0541	0.1082	0.0010	0.001	0.0	N/A
35	0.0643	0.1286	0.0020	0.002	0.0	N/A
36	0.0511	0.1022	0.0010	0.001	0.0	N/A
37	0.0608	0.1216	0.0030	0.003	0.0	N/A
38	0.0484	0.0968	0.0010	0.001	0.0	N/A
39	0.0577	0.1154	0.0021	0.003	0.0	N/A
40	0.0460	0.0920	0.0010	0.002	0.0	N/A

Type of equipment behaviour: Quasi-Stationary

*4 When the Edition 3.0 is applied, 200% of the Limit1 value is applied to each Limit2 value.

HARMONICS CURRENT TEST REPORT

Company	Tescom	Test Engineer	SUNNY
Model name	UPS		
Type	LEO+ 850VA		
Serial No.		Type of test	EN IEC 61000-3-2:2019 *IEC61000-3-2: 2014
Operating mode	Charging+Discharging		EN61000-4-7: 2002/A1:2009 *IEC61000-4-7: 2002+A1:2008
Date of test	2016/07/22 11:55:47	Classification	Class A
Climatic condition	T:26;H:53%	Power analyzer	KHA1000, Ver1.50
Memo		Supply Source	AC 230V/50Hz
		Reference Impedance	

Test Data of Current Harmonics

FINAL TEST RESULT **PASS**

Voltage	230.28V	THC	0.173A
Current	2.448A	POHC/LIMIT	0.009A/ -----A *4
Power	561.59W	Nominal	230V/ 50Hz
Apparent Power	563.8VA	Fundamental current	2.439A
		Measuring period	150s
		Margin	100%

HarmOrder	Limit1(A rms)	Limit2(A rms)	Ave(A rms)	Max(A rms)	LimitOver(s)	Judge
2	1.0800	2.1600	0.1125	0.114	0.0	Pass
3	2.3000	4.6000	0.1144	0.116	0.0	Pass
4	0.4300	0.8600	0.0430	0.044	0.0	Pass
5	1.1400	2.2800	0.0302	0.031	0.0	Pass
6	0.3000	0.6000	0.0160	0.016	0.0	Pass
7	0.7700	1.5400	0.0120	0.013	0.0	N/A
8	0.2300	0.4600	0.0080	0.009	0.0	N/A
9	0.4000	0.8000	0.0102	0.011	0.0	N/A
10	0.1840	0.3680	0.0040	0.004	0.0	N/A
11	0.3300	0.6600	0.0060	0.006	0.0	N/A
12	0.1533	0.3066	0.0021	0.003	0.0	N/A
13	0.2100	0.4200	0.0014	0.002	0.0	N/A
14	0.1314	0.2628	0.0020	0.003	0.0	N/A
15	0.1500	0.3000	0.0050	0.005	0.0	N/A
16	0.1150	0.2300	0.0020	0.002	0.0	N/A
17	0.1324	0.2648	0.0060	0.006	0.0	N/A
18	0.1022	0.2044	0.0027	0.003	0.0	N/A
19	0.1184	0.2368	0.0050	0.005	0.0	N/A
20	0.0920	0.1840	0.0020	0.002	0.0	N/A
21	0.1071	0.2142	0.0040	0.004	0.0	N/A
22	0.0836	0.1672	0.0020	0.002	0.0	N/A
23	0.0978	0.1956	0.0050	0.005	0.0	N/A
24	0.0767	0.1534	0.0010	0.001	0.0	N/A
25	0.0900	0.1800	0.0030	0.003	0.0	N/A
26	0.0708	0.1416	0.0010	0.001	0.0	N/A
27	0.0833	0.1666	0.0010	0.001	0.0	N/A
28	0.0657	0.1314	0.0010	0.002	0.0	N/A
29	0.0776	0.1552	0.0021	0.003	0.0	N/A
30	0.0613	0.1226	0.0010	0.002	0.0	N/A
31	0.0726	0.1452	0.0020	0.002	0.0	N/A
32	0.0575	0.1150	0.0010	0.001	0.0	N/A
33	0.0682	0.1364	0.0010	0.001	0.0	N/A
34	0.0541	0.1082	0.0010	0.001	0.0	N/A
35	0.0643	0.1286	0.0020	0.002	0.0	N/A
36	0.0511	0.1022	0.0010	0.001	0.0	N/A
37	0.0608	0.1216	0.0030	0.003	0.0	N/A
38	0.0484	0.0968	0.0010	0.001	0.0	N/A
39	0.0577	0.1154	0.0021	0.003	0.0	N/A
40	0.0460	0.0920	0.0010	0.001	0.0	N/A

Type of equipment behaviour: Quasi-Stationary

*4 When the Edition 3.0 is applied, 200% of the Limit1 value is applied to each Limit2 value.

10. IMMUNITY PERFORMANCE CRITERIA

The test results shall be classified in terms of the loss of function or degradation of performance of the equipment under test, relative to a performance level by its manufacturer or the requestor of the test, or the agreed between the manufacturer and the purchaser of the product.

	Criterion A	Criterion B
Output characteristics	Voltage permitted to vary only within the steady-state characteristics applicable (100m sec limits in Figures 1, 2 or 3 of IEC 62040-3)	Voltage permitted to vary within the inverse time characteristics applicable (<100m sec limits in Figures 1, 2 or 3 of IEC 62040-3)
External and internal indications and metering	Change only during test	Change only during test
Control signals to external	No change	Change only temporarily in consistency with the actual UPS UNINTERRUPTIBLE POWER SUPPLY mode of operation
Mode of operation	No change	Change only temporarily

11. LOW FREQUENCY SIGNALS TEST

11.1. Configuration of Test System

11.1.1. Block Diagram of connection between EUT and simulation

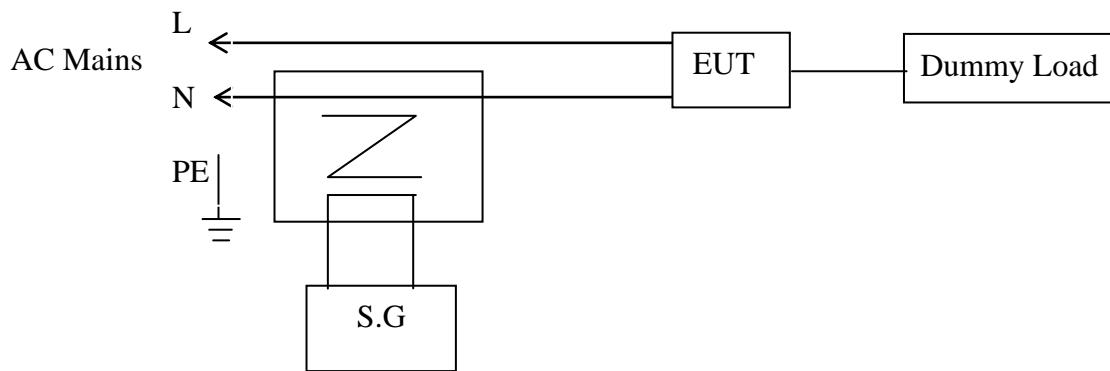

(EUT: UPS UNINTERRUPTIBLE POWER SUPPLY)

11.1.2. Block Diagram of Test Setup

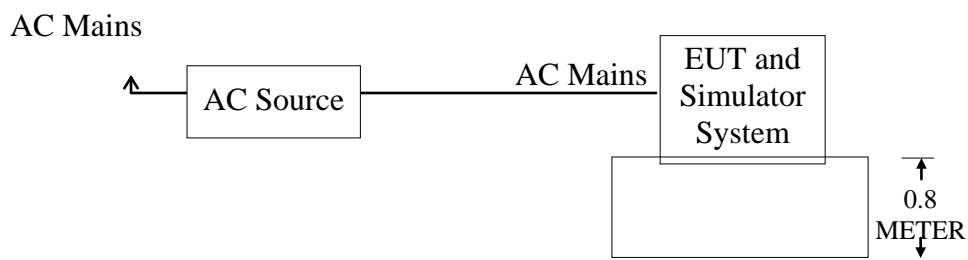

11.2. Test Standard

EN IEC 62040-2:2018 (IEC 61000-2-2:2002+A1:2017+A2:2018), Performance Criterion: A

11.3. Test Results

11.3.1. Test Results: **PASS**

11.3.2. Test data on the following pages.

Low Frequency Signals Test Results

Shenzhen Most Technology Service Co., Ltd.

Test Voltage : 1	Test Date : Jul.26, 2016
Test Mode : 1	Criterion : A
Temperature: 24 °C	Humidity: 53 %

Frequency Range (Hz)	Position	Strength	Results	Note
140	See Fig.1	10V(rms) Sinusoidal	Pass	
160			Pass	
200			Pass	
240			Pass	
280			Pass	
320			Pass	
360			Pass	

Note:

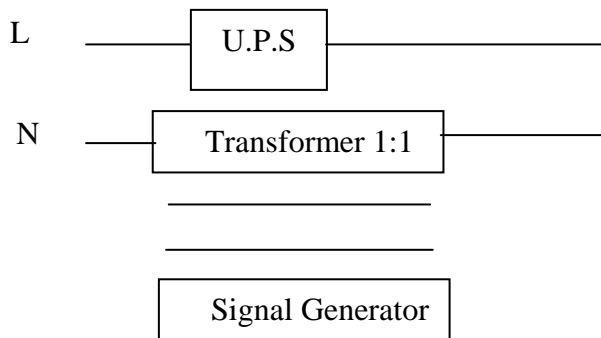

Fig.1

Test Equipment :
 1. Isolation Transformer
 Primary:Secondary=1:1
 2. Signal Generator
 AC Source:6590 (Chroma)

Reviewer: _____

Sunny

12.ELECTROSTATIC DISCHARGE IMMUNITY TEST

12.1.Configuration of Test System

12.1.1. Configuration of ESD Test System

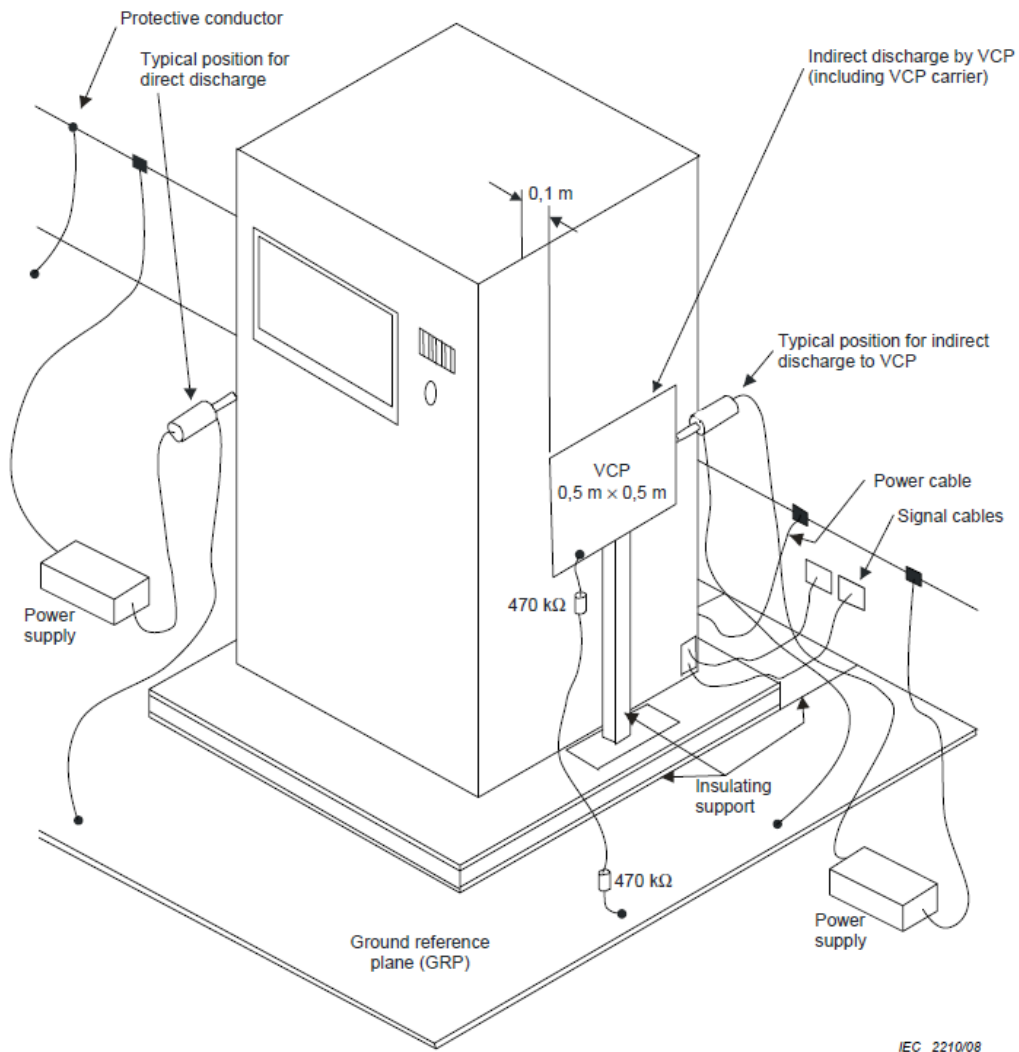

IEC 2210/08

12.2.Test Standard

EN IEC 62040-2:2018 (IEC 61000-4-2:2008)
 (Severity Level 3 for Air Discharge at 8KV,
 Severity Level 2 for Contact Discharge at 4KV)

12.3. Severity Levels and Performance Criterion

12.3.1. Severity level

Level	Test Voltage Contact Discharge (KV)	Test Voltage Air Discharge (KV)
1.	2	2
2.	4	4
3.	6	8
4.	8	15
X	Special	Special

12.3.2. Performance criterion : **B**

12.4. Test Procedure

12.4.1. Air Discharge:

The test was applied on non-conductive surfaces of EUT. The round discharge tip of the discharge electrode was approached as fast as possible to touch the EUT. After each discharge, the discharge electrode was removed from the EUT. The generator was re-triggered for a new single discharge and repeated 20 times for each pre-selected test point. This procedure was repeated until all the air discharge completed

12.4.2. Contact Discharge:

All the procedure was same as Section 11.4.1. except that the generator was re-triggered for a new single discharge and repeated 50 times for each pre-selected test point. the tip of the discharge electrode was touch the EUT before the discharge switch was operated.

12.5. Test Results

12.5.1. Test Results: **PASS**

12.5.2. Test data on the following pages.

Electrostatic Discharge Test Results

Shenzhen Most Technology Service Co., Ltd.

<i>Test Voltage</i> :	1&2	<i>Test Date:</i>	Jul.26, 2016
<i>Test Mode</i> :	1&2&3	<i>Criterion</i> :	B
<i>Temperature:</i>	25 °C	<i>Humidity:</i>	59 %
<p><i>Air Discharge: ±8KV</i> # For Air Discharge each Point Positive 10 times and negative 10 times discharge.</p> <p><i>Contact Discharge: ±4KV</i> # For Contact Discharge each point positive 25 times and negative 25 times discharge</p>			
<i>Test Results Description</i>			
Location	Kind A-Air Discharge C-Contact Discharge	Result	
<i>Gaps</i>	A	PASS	
<i>Switch</i>	A	PASS	
<i>Screw</i>	C	PASS	
<i>Port</i>	C	PASS	
<i>HCP</i>	C	PASS	
<i>VCP of Front</i>	C	PASS	
<i>VCP of Rear</i>	C	PASS	
<i>VCP of Left</i>	C	PASS	
<i>VCP of Right</i>	C	PASS	
<p><i>Remark : Two test modes the test results for 1 and 2 are the same.</i></p>			

Discharge was considered on Contact and Air and Horizontal Coupling Plane (HCP) and Vertical Coupling Plane (VCP).

Reviewer :  _____

13. RF FIELD STRENGTH SUSCEPTIBILITY TEST

13.1. Configuration of Test System

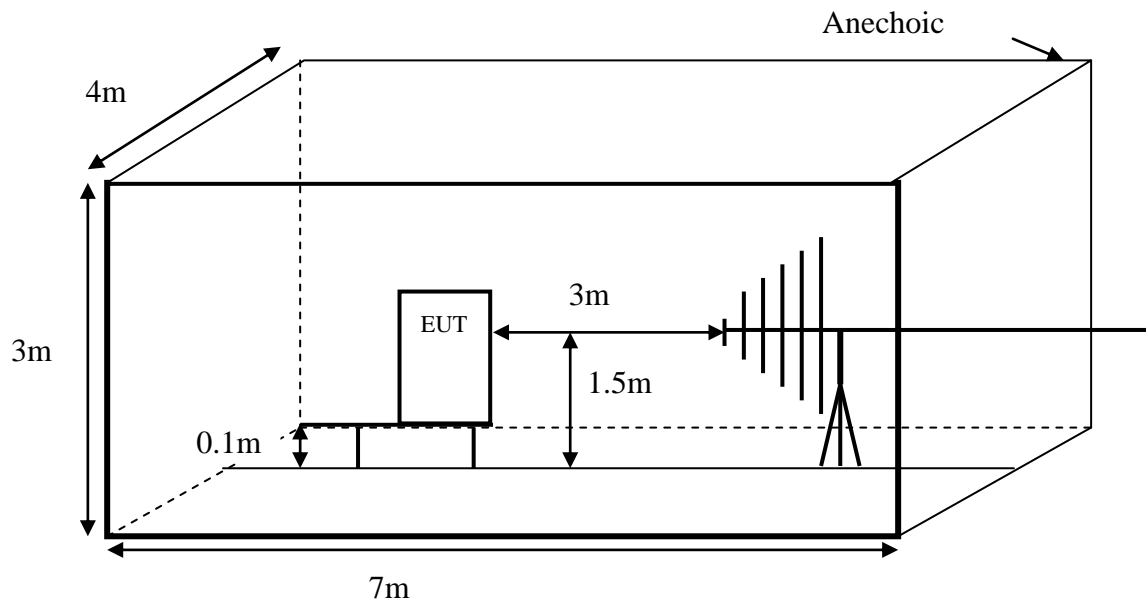

13.2. Test Standard

EN IEC 62040-2:2018 (IEC 61000-4-3:2006)
(Severity Level: 3 at 10V / m)

13.3. Severity Levels and Performance Criterion

13.3.1. Severity level

Level	Test Field Strength V/m
1.	1
2.	3
3.	10
X	Special

13.3.2. Performance criterion : A

13.4. Test Procedure

Testing was performed in a Fully anechoic chamber as recommended by IEC 61000-4-3. The EUT was placed on an 10 cm high non-conductive table located in the area of field uniformity. The radiating antenna was placed 3m in front of the EUT and Support system, and dwell time of the radiated interference was controlled by an automated, computer-controlled system. The signal source was stepped through the applicable frequency range at a rate no faster than 1% of the fundamental. The signal was amplitude modulated 80% over the frequency range 80 MHz to 1GHz at a level of 10 V/m. The dwell time was set at 1.5 s. Field presence was monitored during testing via a field probe placed in close proximity to the EUT. Throughout testing, the EUT was closely monitored for signs of susceptibility. The test was performed with the antennae oriented in both a horizontal and vertical polarization.

All the scanning conditions are as follows :

Condition of Test	Remarks
1. Test Fielded Strength	10 V/m (Severity Level 2)
2. Radiated Signal	80% amplitude modulated with a 1kHz sine wave
3. Scanning Frequency	80 - 1000 MHz
4. Sweeping time of radiated	0.0015 decade/s
5. Dwell Time	1.5 Sec.

13.5. Test Results

13.5.1. Test Results: **PASS**

13.5.2. Test data on the following pages.

RF Field Strength Susceptibility Test Results

Shenzhen Most Technology Service Co., Ltd.

<i>Test Voltage</i> :	<i>1&2</i>	<i>Test Date:</i>	<i>Jul.26, 2016</i>
<i>Test Mode:</i>	<i>1&2&3</i>	<i>Frequency Range:</i>	<i>80-1000MHz</i>
<i>Field Strength:</i>	<i>10 V/m</i>	<i>Criterion</i> :	<i>A</i>
<i>Temperature:</i>		<i>Humidity:</i>	
<i>Modulation:</i> <input checked="" type="checkbox"/> <i>AM</i> <input type="checkbox"/> <i>Pulse</i> <input type="checkbox"/> <i>none</i> <i>1 kHz 80%</i>			
<i>Test Results Description</i>			
<i>Frequency Rang 1: 80MHz - 1000 MHz</i>			
<i>Steps</i>	<i>1%</i>	<i>1%</i>	
	<i>Horizontal</i>	<i>Vertical</i>	
<i>Front</i>	<i>PASS</i>	<i>PASS</i>	
<i>Right</i>	<i>PASS</i>	<i>PASS</i>	
<i>Rear</i>	<i>PASS</i>	<i>PASS</i>	
<i>Left</i>	<i>PASS</i>	<i>PASS</i>	
 <i>Note: No function loss</i> <i>Two test modes the test results for 1 and 2 are the same.</i>			

Reviewer :

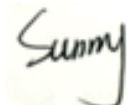

14.ELECTRICAL FAST TRANSIENT/BURST IMMUNITY TEST

14.1.Configuration of Test System

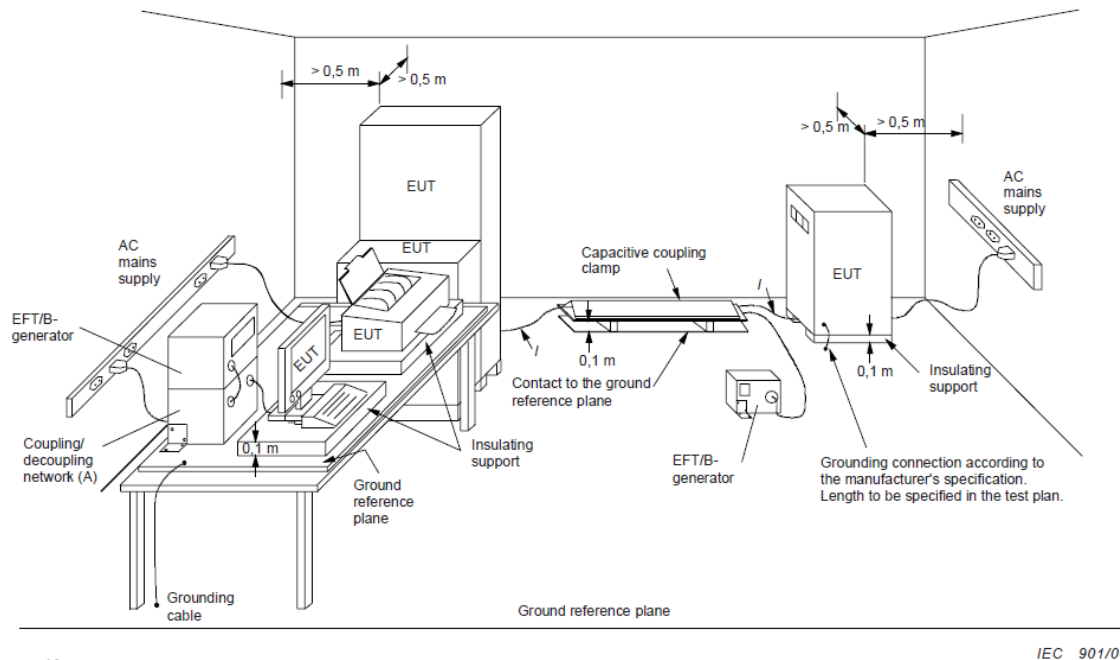

14.2.Test Standard

EN IEC 62040-2:2018 (IEC 61000-4-4:2012)
(Severity Level 3 at 2KV)

14.3.Severity Levels and Performance Criterion

14.3.1.Severity level

Open Circuit Output Test Voltage $\pm 10\%$		
Level	On Power Supply Lines	On I/O (Input/Output) Signal data and control lines
1.	0.5 KV	0.25 KV
2.	1 KV	0.5 KV
3.	2 KV	1 KV
4.	4 KV	2 KV
X	Special	Special

14.3.2.Performance criterion : **B**

14.4. Test Procedure

The EUT and its simulators were placed on a the ground reference plane and were insulated from it by an wood support $0.1\text{m} \pm 0.01\text{m}$ thick. The ground reference plane was $1\text{m} \times 1\text{m}$ metallic sheet with 0.65mm minimum thickness. This reference ground plane was project beyond the EUT by at least 0.1m on all sides and the minimum distance between EUT and all other conductive structure, except the ground plane was more than 0.5m . All cables to the EUT was placed on the wood support, cables not subject to EFT/B was routed as far as possible from the cable under test to minimize the coupling between the cables.

14.4.1. For input and AC power ports:

The EUT was connected to the power mains by using a coupling device which couples the EFT interference signal to AC power lines. Both positive transients and negative transients of test voltage was applied during compliance test and the duration of the test can't less than 2mins.

14.4.2. For signal lines and control lines ports:

It's unnecessary to test.

14.4.3. For DC input and DC output power ports:

It's unnecessary to test.

14.5. Test Results

14.5.1. Test Results: **PASS**

14.5.2. Test data on the following pages.

Electrical Fast Transient/Burst Test Results

Shenzhen Most Technology Service Co., Ltd.

<i>Test Voltage</i> : 1	<i>Test Date</i> : Jul.26, 2016
<i>Test Mode</i> : 1&2	<i>Criterion</i> : B
<i>Temperature:</i> 26 °C	<i>Humidity:</i> 61 %

Test Results Description

<i>Inject Line</i>	<i>Voltage KV</i>	<i>Inject Time(s)</i>	<i>Inject Method</i>	<i>Results</i>	<i>Inject Line</i>	<i>Voltage KV</i>	<i>Inject Time(s)</i>	<i>Inject Method</i>	<i>Results</i>
L	±2	120	Direct	PASS					
N	±2	120	Direct	PASS					
L+N	±2	120	Direct	PASS					
PE	±2	120	Direct	PASS					
L+PE	±2	120	Direct	PASS					
N+PE	±2	120	Direct	PASS					
L+N+PE	±2	120	Direct	PASS					

Remark: Two test modes the test results for 1 and 2 are the same.

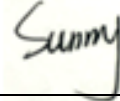
Reviewer : 

15.SURGE TEST

15.1.Configuration of Test System

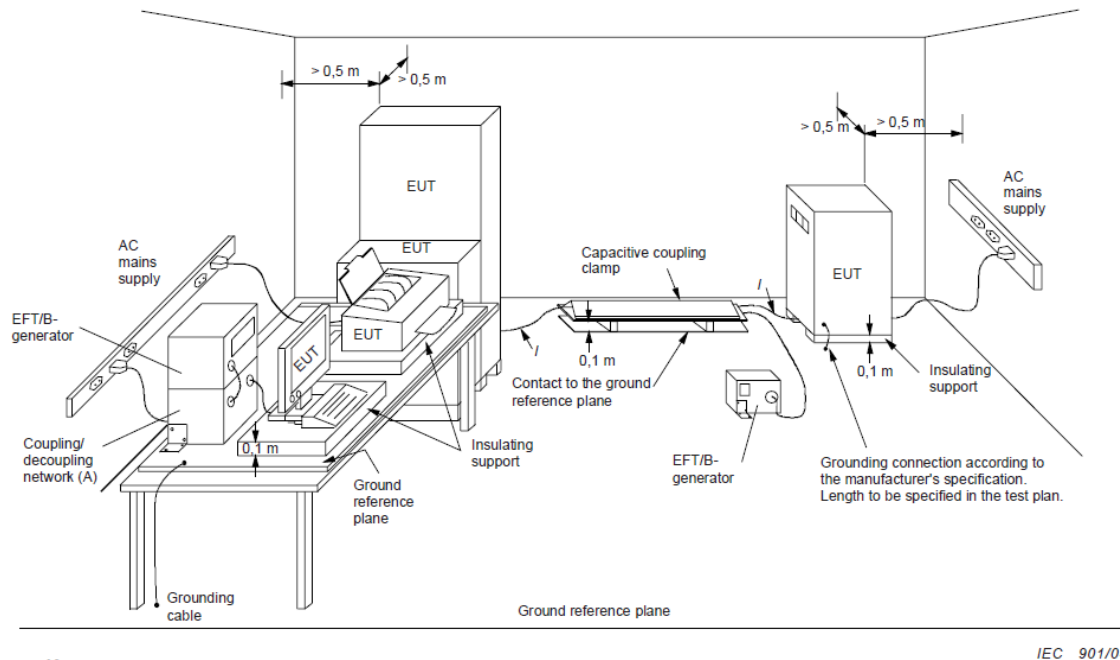

15.2.Test Standard

EN IEC 62040-2:2018 (IEC 61000-4-5:2014)
 (Severity Level : Line to Line was Level 2 at 1KV
 Line to PE was Level 3 at 2KV)

15.3.Severity Levels and Performance Criterion

15.3.1.Severity level

Severity Level	Open-Circuit Test Voltage KV
1	0.5
2	1.0
3	2.0
4	4.0
*	Special

15.3.2.Performance criterion : B

15.4. Test Procedure

- 15.4.1. Set up the EUT and test generator as shown on Section 14.1.
- 15.4.2. For line to line coupling mode, provide a 1KV 1.2/50us voltage surge (at open-circuit condition) and 8/20us current surge to EUT selected points, and for active line / neutral line to ground are same except test level is 2KV.
- 15.4.3. At least 5 positive and 5 negative (polarity) tests with a maximum 1/min repetition rate are applied during test.
- 15.4.4. Different phase angles are done individually.
- 15.4.5. Record the EUT operating situation during compliance test and decide the EUT immunity criterion for above each test.

15.5. Test Results

- 15.5.1. Test Results: **PASS**
- 15.5.2. Test data on the following pages.

Surge Immunity Test Results

Shenzhen Most Technology Service Co., Ltd.

<i>Test Voltage</i> : 1		<i>Test Date</i> : Jul.26, 2016			
<i>Test Mode</i> : 1&2		<i>Criterion</i> : B			
<i>Temperature</i> : 26°C		<i>Humidity</i> : 61 %			
<i>Test Results Description</i>					
<i>Location</i>	<i>Polarity</i>	<i>Phase Angle</i>	<i>No of Pulse</i>	<i>Pulse Voltage (KV)</i>	<i>Result</i>
<i>L-N</i>	±	0	5	1.0	<i>PASS</i>
		90	5	1.0	<i>PASS</i>
		180	5	1.0	<i>PASS</i>
		270	5	1.0	<i>PASS</i>
<i>L-PE</i>	±	0	5	2.0	<i>PASS</i>
		90	5	2.0	<i>PASS</i>
		180	5	2.0	<i>PASS</i>
		270	5	2.0	<i>PASS</i>
<i>N-PE</i>	±	0	5	2.0	<i>PASS</i>
		90	5	2.0	<i>PASS</i>
		180	5	2.0	<i>PASS</i>
		270	5	2.0	<i>PASS</i>
<i>L+N-PE</i>	±	0	5	2.0	<i>PASS</i>
		90	5	2.0	<i>PASS</i>
		180	5	2.0	<i>PASS</i>
		270	5	2.0	<i>PASS</i>
<i>Remark: Two test modes the test results for 1 and 2 are the same.</i>					

Reviewer : Sunny

16. INJECTED CURRENTS SUSCEPTIBILITY TEST

16.1. Configuration of Test System

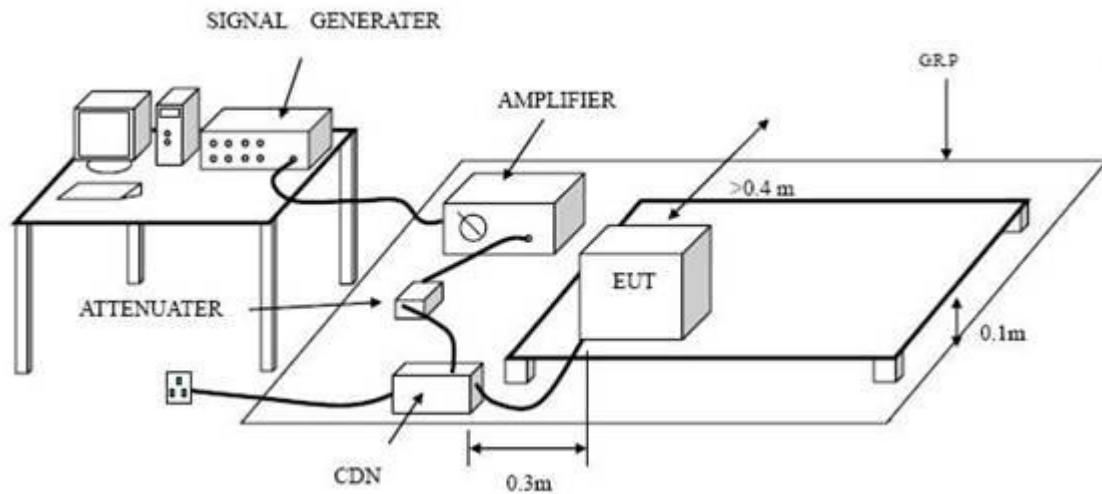

16.2. Test Standard

EN IEC 62040-2:2018 (IEC 61000-4-6:2013)
 (Severity Level 3 at 10V (r.m.s.) and frequency is from 0.15MHz to 80MHz)

16.3. Severity Levels and Performance Criterion

16.3.1. Severity level

Level	Voltage Level (e.m.f.) V
1.	1
2.	3
3.	10
X	Special

16.3.2. Performance criterion: A

16.4. Test Procedure

16.4.1. Set up the EUT, CDN and test generators as shown on Section 15.1.

16.4.2. Let the EUT work in test mode and test it.

16.4.3. The EUT are placed on an insulating support 0.1m high above a ground reference plane. CDN (coupling and decoupling device) is placed on the ground plane about 0.3m from EUT. Cables between CDN and EUT are as short as possible, and their height above the ground reference plane shall be between 30 and 50 mm (where possible).

16.4.4. The disturbance signal description below is injected to EUT through CDN.

16.4.5. The EUT operates within its operational mode(s) under intended climatic conditions after power on.

16.4.6. The frequency range is swept from 0.150MHz to 80MHz using 10V signal level, and with the disturbance signal 80% amplitude modulated with a 1KHz sine wave.

16.4.7. The rate of sweep shall not exceed 1.5×10^{-3} decades/s. Where the frequency is swept incrementally, the step size shall not exceed 1% of the start and thereafter 1% of the preceding frequency value.

16.4.8. Recording the EUT operating situation during compliance testing and decide the EUT immunity criterion.

16.5. Test Results

16.5.1. Test Results: **PASS**

16.5.2. Test data on the following pages.

Injected Currents Susceptibility Test Results

Shenzhen Most Technology Service Co., Ltd.

<i>Power Supply :</i>	1	<i>Test Date:</i>	Jul.26, 2016
<i>Test Mode :</i>	1&2	<i>Criterion:</i>	A
<i>Temperature:</i>	24 °C	<i>Humidity:</i>	56 %

Test Results Description

<i>Frequency Range (MHz)</i>	<i>Injected Position</i>	<i>Voltage Level (e.m.f.)</i>	<i>Criterion</i>	<i>Result</i>
0.15 ~ 80	AC Mains	10V(rms), Unmodulated	A	PASS

*Remark : No function loss
Two test modes the test results for 1 and 2 are the same.*

Reviewer : 

17.MAGNETIC FIELD IMMUNITY TEST

17.1.Configuration of Test System

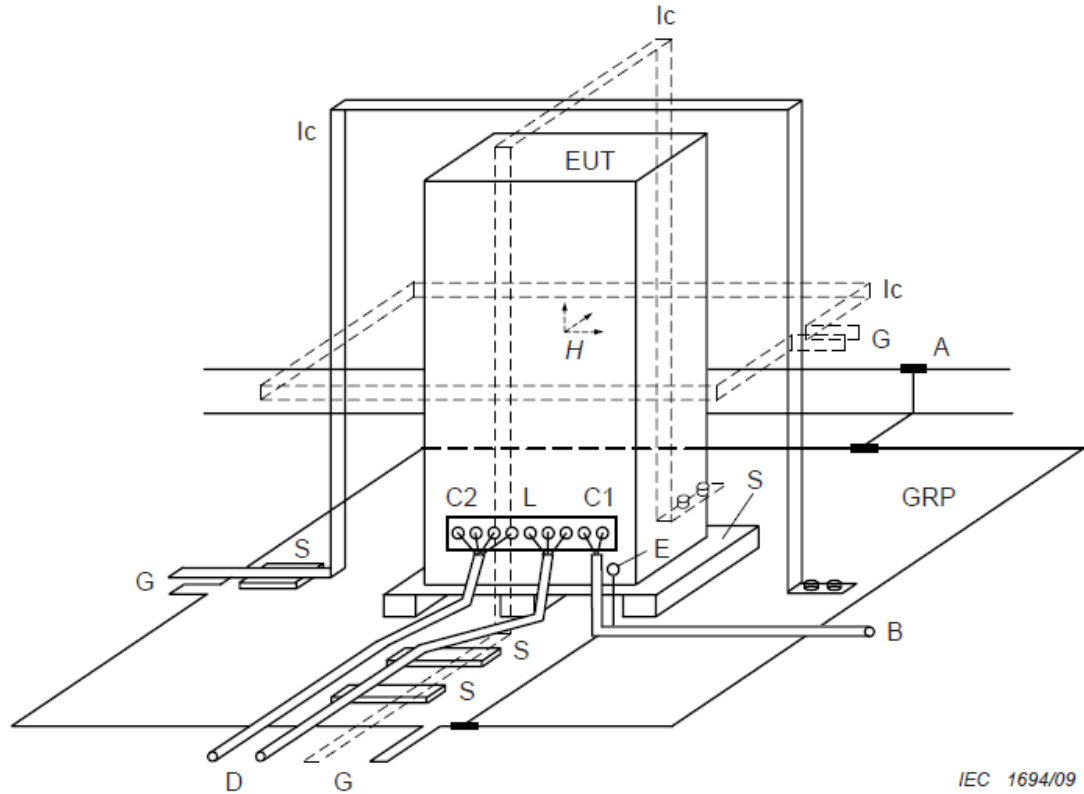

17.2.Test Standard

EN IEC 62040-2:2018 (IEC 61000-4-8:2009)
(Severity Level 4 at 30A/m)

17.3.Severity Levels and Performance Criterion

17.3.1.Severity level

Level	Magnetic Field Strength A/m
1.	1
2.	3
3.	10
4.	30
5.	100
X.	Special

17.3.2.Performance criterion : A

17.4. Test Procedure

The EUT was subjected to the test magnetic field by using the induction coil of standard dimensions (1m*1m) and shown in Section 16.1. The induction coil was then rotated by 90° in order to expose the EUT to the test field with different orientations.

17.5. Test Results

17.5.1. Test Results: **PASS**

17.5.2. Test data on the following pages.

Magnetic Field Immunity Test Results

Shenzhen Most Technology Service Co., Ltd.

<i>Test Voltage :</i>	1&2	<i>Test Date:</i>	Jul.26, 2016	
<i>Test Mode :</i>	1&2&3	<i>Criterion :</i>	A	
<i>Temperature:</i>	24 °C	<i>Humidity:</i>	59 %	
<i>Test Results Description</i>				
<i>Test Level</i>	<i>Testing Duration</i>	<i>Coil Orientation</i>	<i>Criterion</i>	<i>Result</i>
30A/m(50Hz/60Hz)	5 mins	X	A	PASS
30A/m(50Hz/60Hz)	5 mins	Y	A	PASS
30A/m(50Hz/60Hz)	5 mins	Z	A	PASS
<p><i>Remark: No function loss</i> <i>Two test modes the test results for 1 and 2 are the same.</i></p>				

Reviewer : 

18. VOLTAGE DIPS AND INTERRUPTIONS TEST

18.1. Configuration of Test System

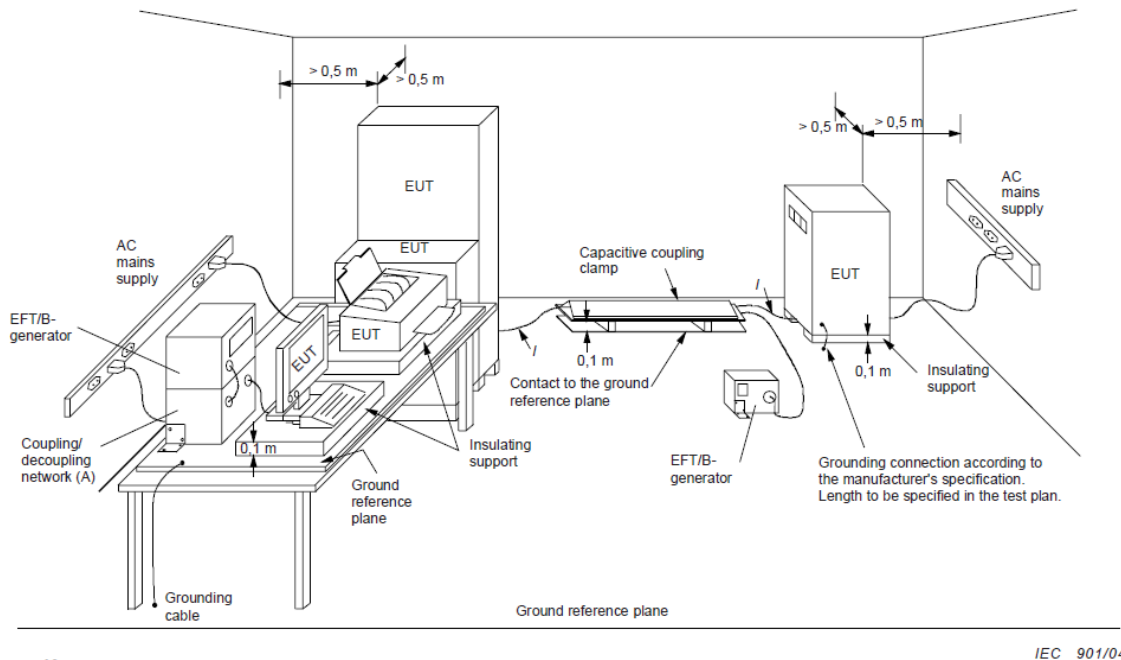

18.2. Test Standard

EN IEC 62040-2:2018 (IEC 61000-4-11:2004)
 (Severity level: 0% 250 period
 0% 0.5 periods
 70% 25 periods)

18.3. Severity Levels and Performance Criterion

18.3.1. Severity level

Test Level % U _T	Voltage dip and short interruptions % U _T	Performance Criterion	Duration (in period)
0	100	B	250
0	100	B	0.5
70	30	B	25

18.3.2. Performance criterion : **B**

18.4. Test Procedure

18.4.1. The EUT and test generator were setup as shown on Section 17.1.

18.4.2. The interruptions is introduced at selected phase angles with specified duration.

18.4.3. Record any degradation of performance.

18.5. Test Results

18.5.1. Test Results: **PASS**

18.5.2. Test data on the following pages.

Voltage Dips And Interruptions Test Results

Shenzhen Most Technology Service Co., Ltd.

<i>Test Voltage :</i>	1	<i>Test Date:</i>	Jul.26, 2016
<i>Test Mode :</i>	1&2	<i>Criterion :</i>	B
<i>Temperature:</i>	26 °C	<i>Humidity:</i>	61 %

Test Results Description

Test Level % U_T	Voltage Dips & Short Interruptions % U_T	Duration (in period)	Phase Angle	Criterion	Result
0	100	250P	0°~360°	B	PASS
70	30	25P	0°~360°	B	PASS
0	100	0.5P	0°~360°	B	PASS

*Remark: U_T is the rated voltage for the equipment.
Two test modes the test results for 1 and 2 are the same.*

Reviewer :  _____

APPENDIX I

EUT:	UPS	M/N:	LEO+ 650VA
Mode:	Charging	Phase:	L
Test by:	hzy	Power:	AC 230V/50Hz
Temperature: / Humidity	24.4°C/51.5%	Test date:	2016-07-28

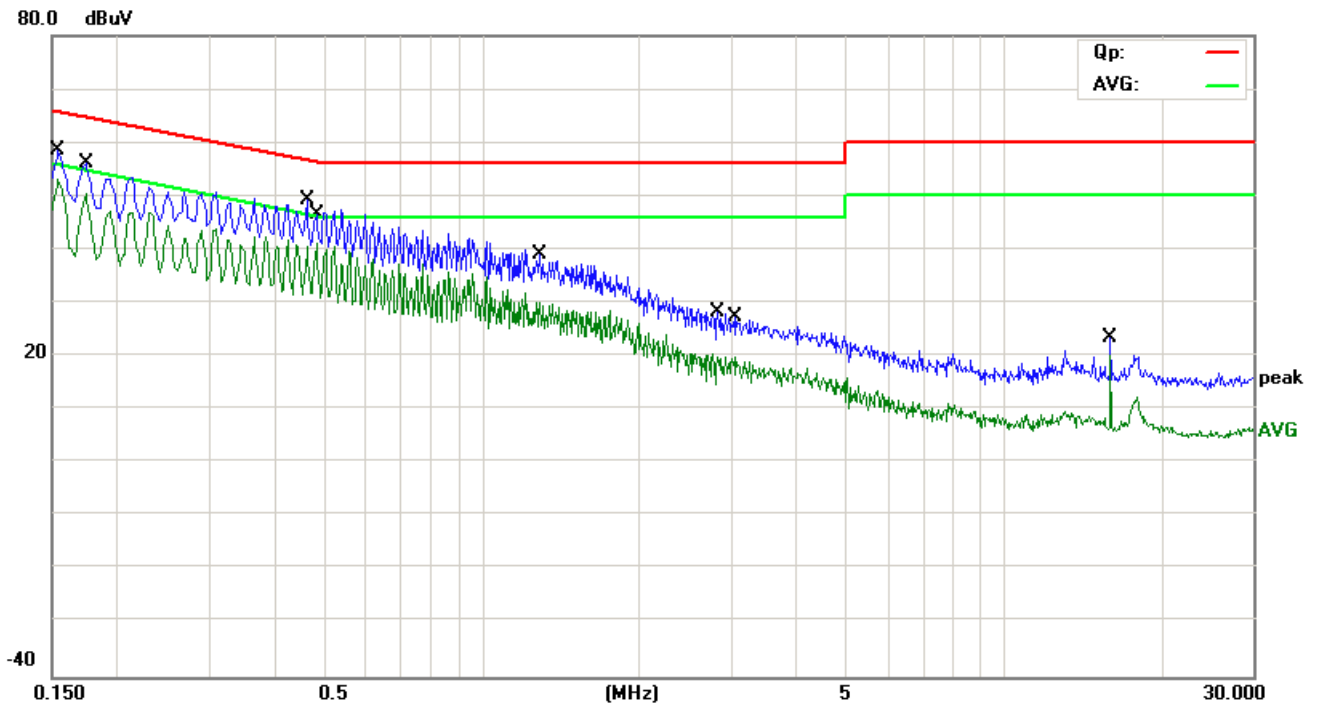

No.	Mk.	Freq. MHz	Reading Level dBuV	Correct Factor dB	Measure- ment dBuV	Limit dBuV	Over dB	Detector	Comment
1		0.1540	44.10	9.60	53.70	65.78	-12.08	QP	
2		0.1540	40.20	9.60	49.80	55.78	-5.98	AVG	
3		0.1740	46.64	9.61	56.25	64.77	-8.52	QP	
4	*	0.1740	40.79	9.61	50.40	54.77	-4.37	AVG	
5		0.4620	39.61	9.59	49.20	56.66	-7.46	QP	
6		0.4820	31.54	9.59	41.13	46.30	-5.17	AVG	
7		1.2900	29.32	9.60	38.92	56.00	-17.08	QP	
8		1.2900	20.53	9.60	30.13	46.00	-15.87	AVG	
9		2.8300	18.55	9.61	28.16	56.00	-27.84	QP	
10		3.0420	10.36	9.61	19.97	46.00	-26.03	AVG	
11		16.0220	13.61	9.71	23.32	60.00	-36.68	QP	
12		16.0220	10.40	9.71	20.11	50.00	-29.89	AVG	

*:Maximum data x:Over limit !:over margin

EUT:	UPS	M/N:	LEO+ 650VA
Mode:	Charging	Phase:	N
Test by:	hzy	Power:	AC 230V/50Hz
Temperature: / Humidity	24.4°C/51.5%	Test date:	2016-07-28

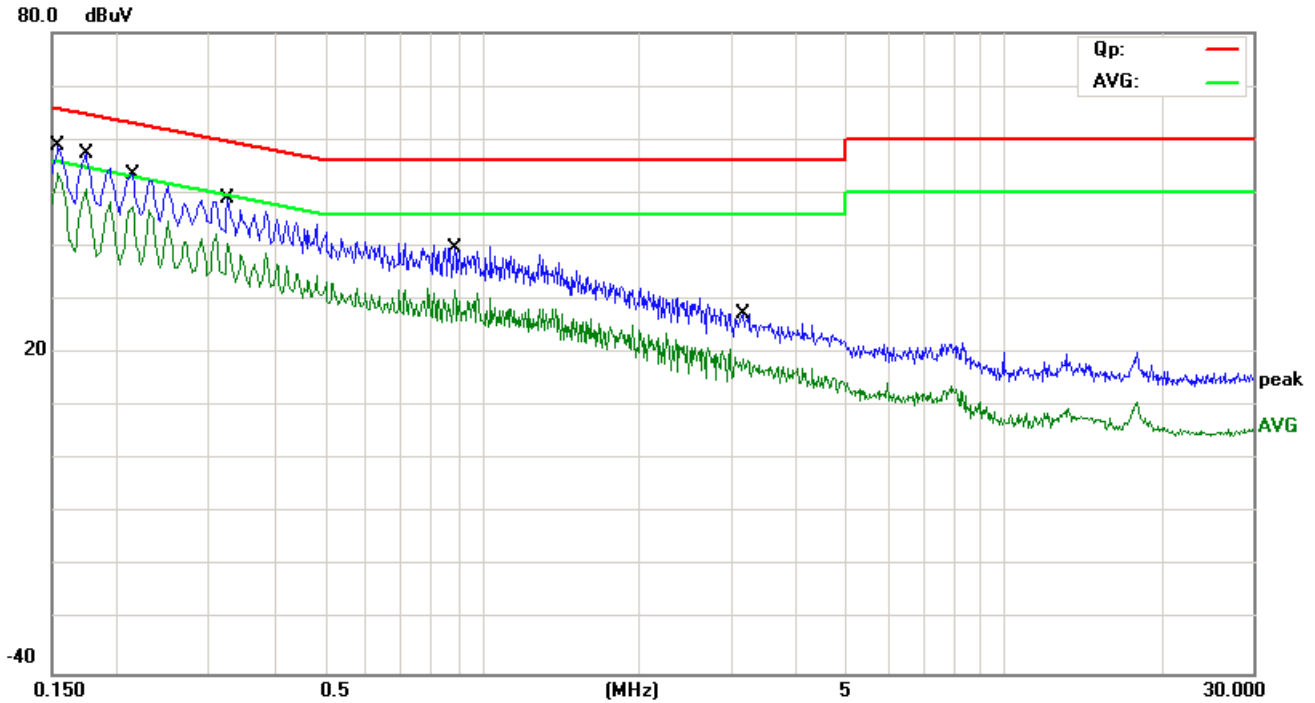

No.	Mk.	Freq. MHz	Reading Level dBuV	Correct Factor dB	Measure- ment dBuV	Limit dBuV	Over dB	Detector	Comment
1		0.1540	43.50	9.60	53.10	65.78	-12.68	QP	
2		0.1540	40.10	9.60	49.70	55.78	-6.08	AVG	
3		0.1740	47.67	9.61	57.28	64.77	-7.49	QP	
4	*	0.1740	41.11	9.61	50.72	54.77	-4.05	AVG	
5		0.2140	43.88	9.60	53.48	63.05	-9.57	QP	
6		0.2140	37.94	9.60	47.54	53.05	-5.51	AVG	
7		0.3267	37.96	9.59	47.55	59.53	-11.98	QP	
8		0.3267	30.32	9.59	39.91	49.53	-9.62	AVG	
9		0.8860	30.19	9.60	39.79	56.00	-16.21	QP	
10		0.8860	22.39	9.60	31.99	46.00	-14.01	AVG	
11		3.1580	17.84	9.61	27.45	56.00	-28.55	QP	
12		3.1580	9.46	9.61	19.07	46.00	-26.93	AVG	

*:Maximum data x:Over limit !:over margin

EUT:	UPS	M/N:	LEO+ 650VA
Mode:	Charging+Discharging	Phase:	L
Test by:	hzy	Power:	AC 230V/50Hz
Temperature: / Humidity	24.4°C/51.5%	Test date:	2016-07-28

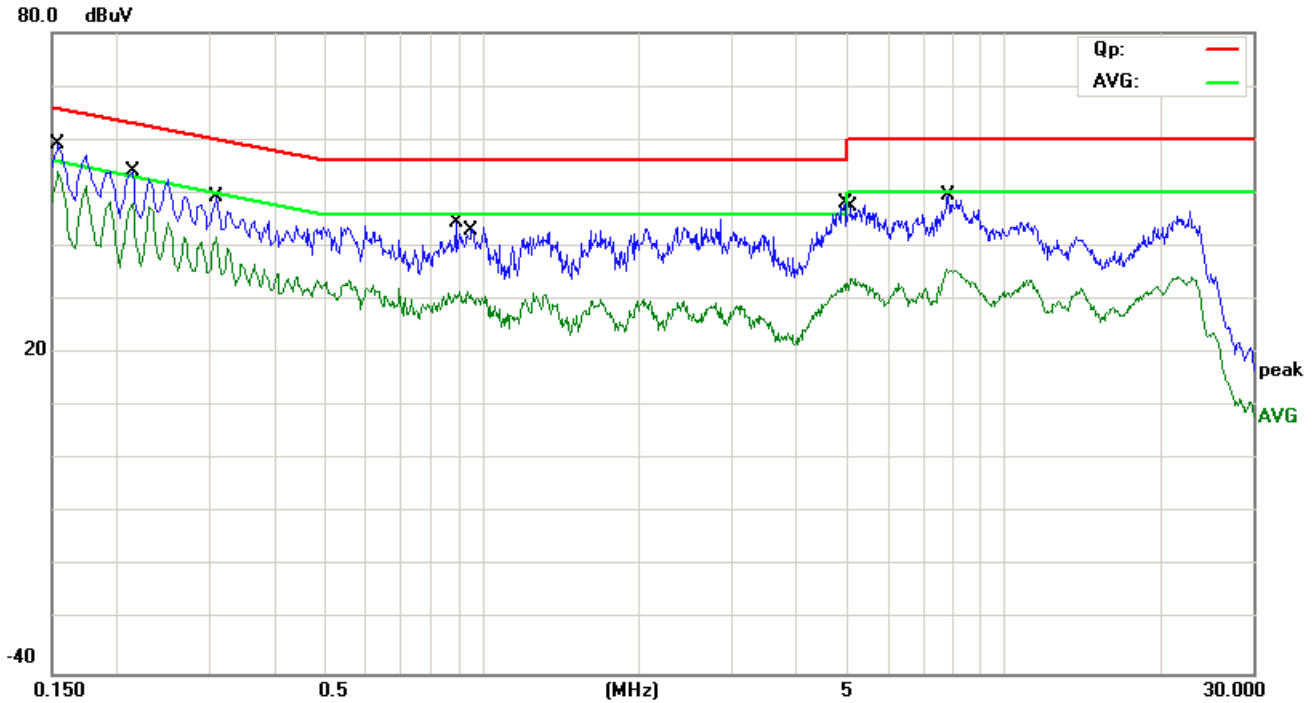

No.	Mk.	Freq. MHz	Reading Level dBuV	Correct Factor dB	Measure- ment dBuV	Limit dBuV	Over dB	Detector	Comment
1		0.1540	43.70	9.60	53.30	65.78	-12.48	QP	
2		0.1540	40.20	9.60	49.80	55.78	-5.98	AVG	
3		0.2140	44.40	9.60	54.00	63.05	-9.05	QP	
4	*	0.2140	38.41	9.60	48.01	53.05	-5.04	AVG	
5		0.3100	39.68	9.59	49.27	59.97	-10.70	QP	
6		0.3100	32.16	9.59	41.75	49.97	-8.22	AVG	
7		0.8900	34.87	9.60	44.47	56.00	-11.53	QP	
8		0.9420	21.99	9.60	31.59	46.00	-14.41	AVG	
9		4.9700	38.48	9.63	48.11	56.00	-7.89	QP	
10		5.0900	24.32	9.63	33.95	50.00	-16.05	AVG	
11		7.7900	25.98	9.66	35.64	50.00	-14.36	AVG	
12		7.8260	39.90	9.66	49.56	60.00	-10.44	QP	

*:Maximum data x:Over limit !:over margin

EUT:	UPS	M/N:	LEO+ 650VA
Mode:	Charging+Discharging	Phase:	N
Test by:	hzy	Power:	AC 230V/50Hz
Temperature: / Humidity	24.4°C/51.5%	Test date:	2016-07-28

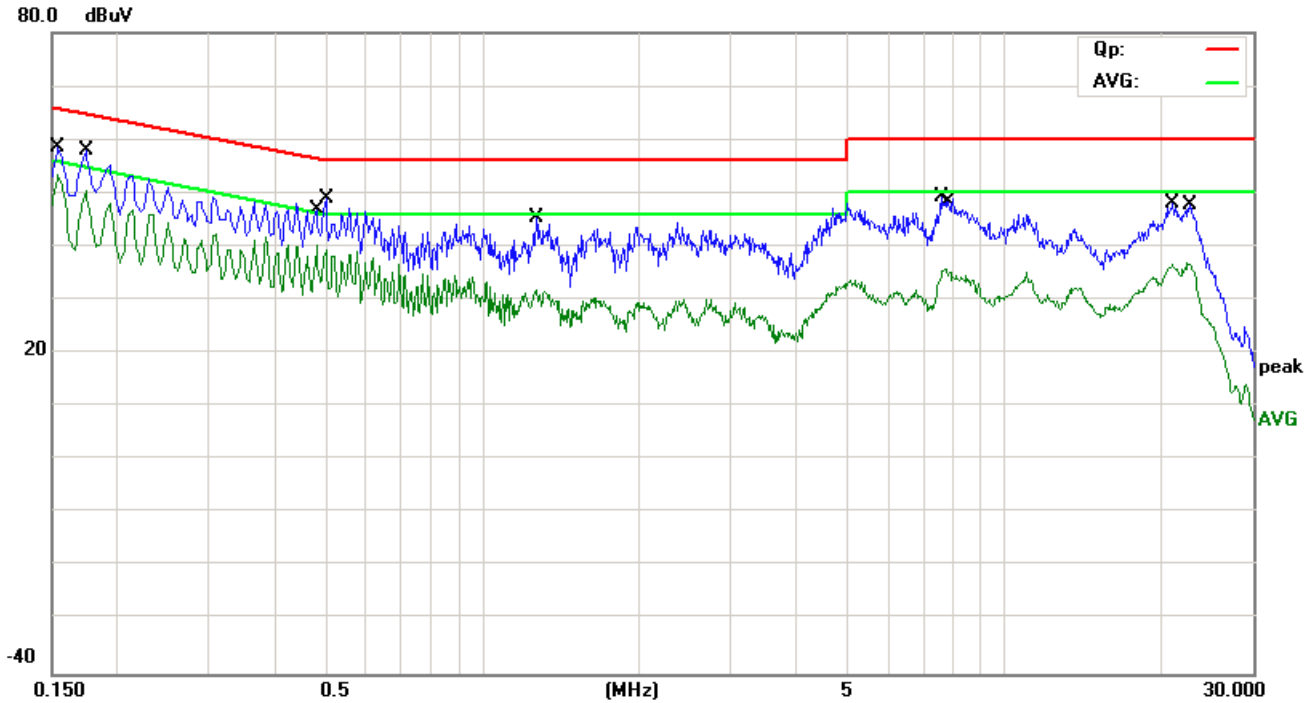

No.	Mk.	Freq. MHz	Reading Level dBuV	Correct Factor dB	Measure- ment dBuV	Limit dBuV	Over dB	Detector	Comment
1		0.1540	43.30	9.60	52.90	65.78	-12.88	QP	
2		0.1540	39.80	9.60	49.40	55.78	-6.38	AVG	
3		0.1740	48.30	9.61	57.91	64.77	-6.86	QP	
4	*	0.1740	40.89	9.61	50.50	54.77	-4.27	AVG	
5		0.4820	30.64	9.59	40.23	46.30	-6.07	AVG	
6		0.5020	39.29	9.59	48.88	56.00	-7.12	QP	
7		1.2700	35.85	9.60	45.45	56.00	-10.55	QP	
8		1.2700	22.28	9.60	31.88	46.00	-14.12	AVG	
9		7.5820	39.62	9.66	49.28	60.00	-10.72	QP	
10		7.7660	26.20	9.66	35.86	50.00	-14.14	AVG	
11		21.1140	38.46	9.73	48.19	60.00	-11.81	QP	
12		22.4540	27.21	9.74	36.95	50.00	-13.05	AVG	

*:Maximum data x:Over limit !:over margin

EUT:	UPS	M/N:	LEO+ 850VA
Mode:	Charging	Phase:	L
Test by:	hzy	Power:	AC 230V/50Hz
Temperature: / Humidity	24.4°C/51.5%	Test date:	2016-07-28

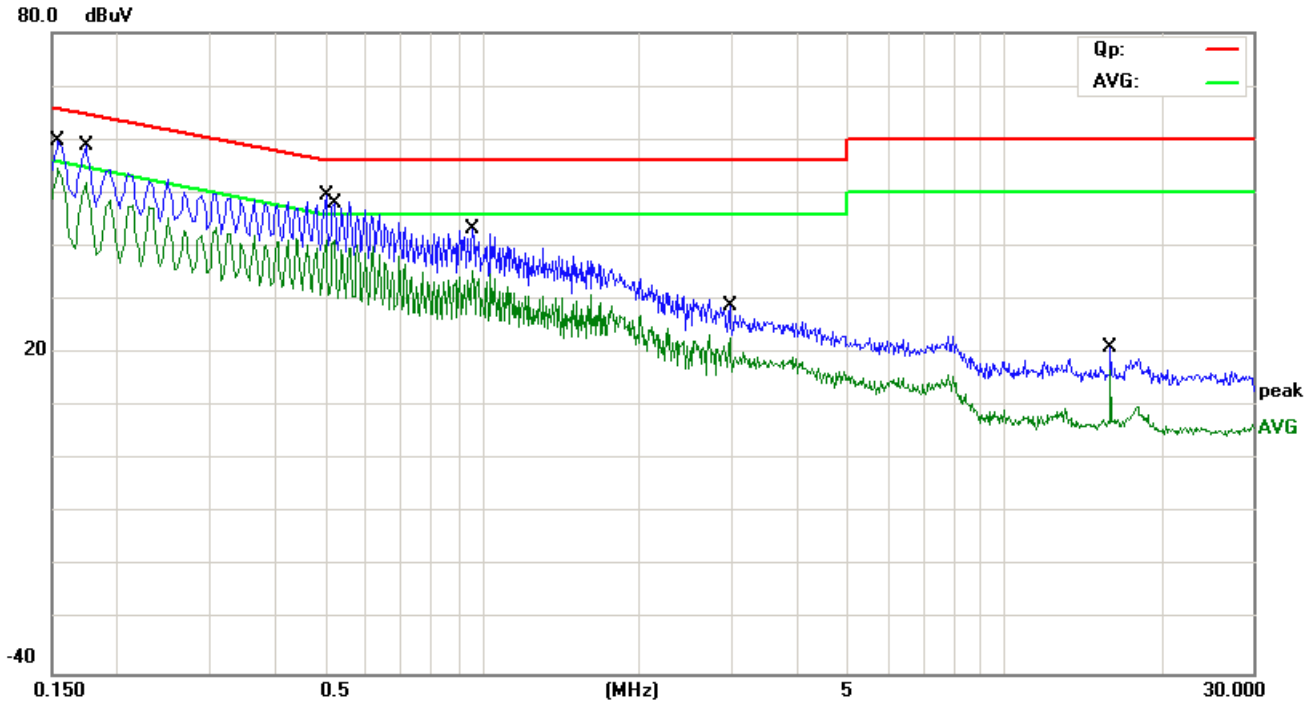

No.	Mk.	Freq. MHz	Reading Level dBuV	Correct Factor dB	Measure- ment dBuV	Limit dBuV	Over dB	Detector	Comment
1		0.1540	44.30	9.60	53.90	65.78	-11.88	QP	
2		0.1540	40.90	9.60	50.50	55.78	-5.28	AVG	
3		0.1740	45.60	9.61	55.21	64.77	-9.56	QP	
4	*	0.1740	41.10	9.61	50.71	54.77	-4.06	AVG	
5		0.5020	39.89	9.59	49.48	56.00	-6.52	QP	
6		0.5220	31.70	9.59	41.29	46.00	-4.71	AVG	
7		0.9620	33.70	9.60	43.30	56.00	-12.70	QP	
8		0.9620	25.98	9.60	35.58	46.00	-10.42	AVG	
9		2.9860	19.17	9.61	28.78	56.00	-27.22	QP	
10		2.9860	13.18	9.61	22.79	46.00	-23.21	AVG	
11		16.0220	11.34	9.71	21.05	60.00	-38.95	QP	
12		16.0220	7.04	9.71	16.75	50.00	-33.25	AVG	

*:Maximum data x:Over limit !:over margin

EUT:	UPS	M/N:	LEO+ 850VA
Mode:	Charging	Phase:	N
Test by:	hzy	Power:	AC 230V/50Hz
Temperature: / Humidity	24.4°C/51.5%	Test date:	2016-07-28

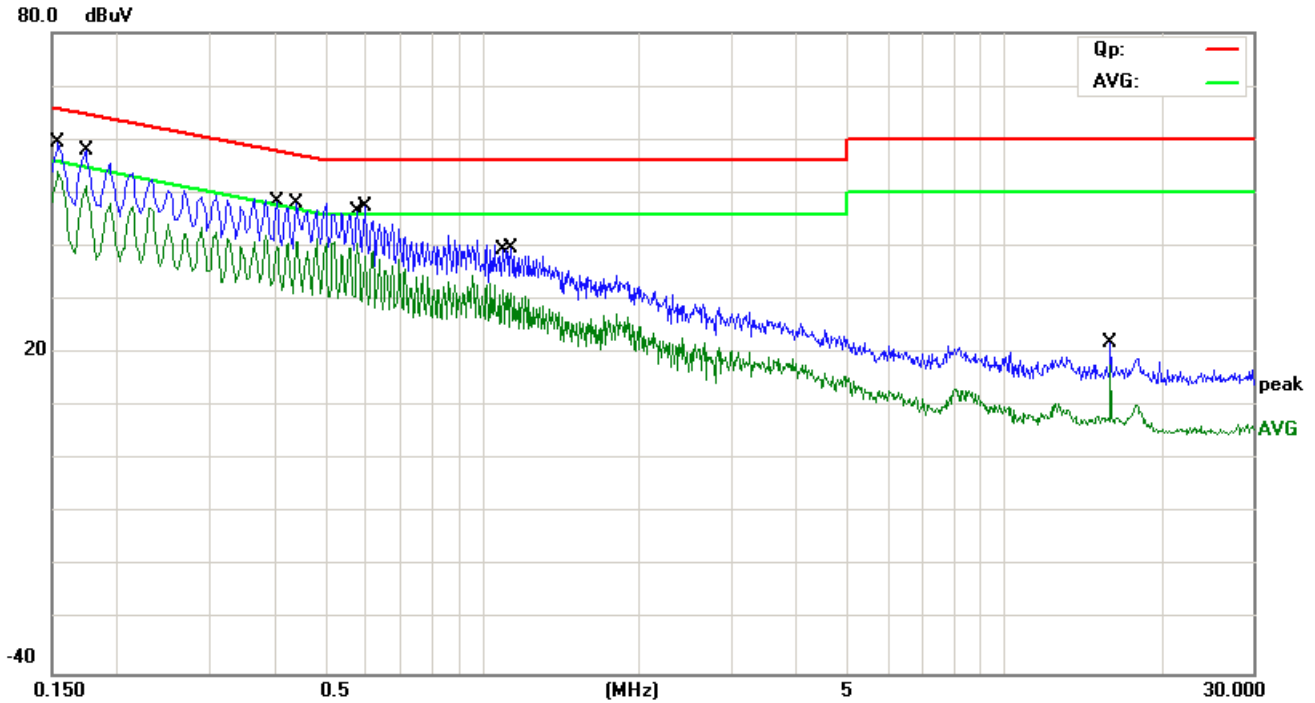

No.	Mk.	Freq. MHz	Reading Level dBuV	Correct Factor dB	Measure- ment dBuV	Limit dBuV	Over dB	Detector	Comment
1		0.1540	43.70	9.60	53.30	65.78	-12.48	QP	
2		0.1540	40.30	9.60	49.90	55.78	-5.88	AVG	
3		0.1740	45.00	9.61	54.61	64.77	-10.16	QP	
4	*	0.1740	40.60	9.61	50.21	54.77	-4.56	AVG	
5		0.4060	38.76	9.59	48.35	57.73	-9.38	QP	
6		0.4420	31.41	9.59	41.00	47.02	-6.02	AVG	
7		0.5780	30.90	9.59	40.49	46.00	-5.51	AVG	
8		0.5980	37.81	9.59	47.40	56.00	-8.60	QP	
9		1.0980	22.12	9.60	31.72	46.00	-14.28	AVG	
10		1.1380	30.13	9.60	39.73	56.00	-16.27	QP	
11		16.0220	12.29	9.71	22.00	60.00	-38.00	QP	
12		16.0220	8.12	9.71	17.83	50.00	-32.17	AVG	

*:Maximum data x:Over limit !:over margin

EUT:	UPS	M/N:	LEO+ 850VA
Mode:	Charging+Discharging	Phase:	L
Test by:	hzy	Power:	AC 230V/50Hz
Temperature: / Humidity	24.4°C/51.5%	Test date:	2016-07-28

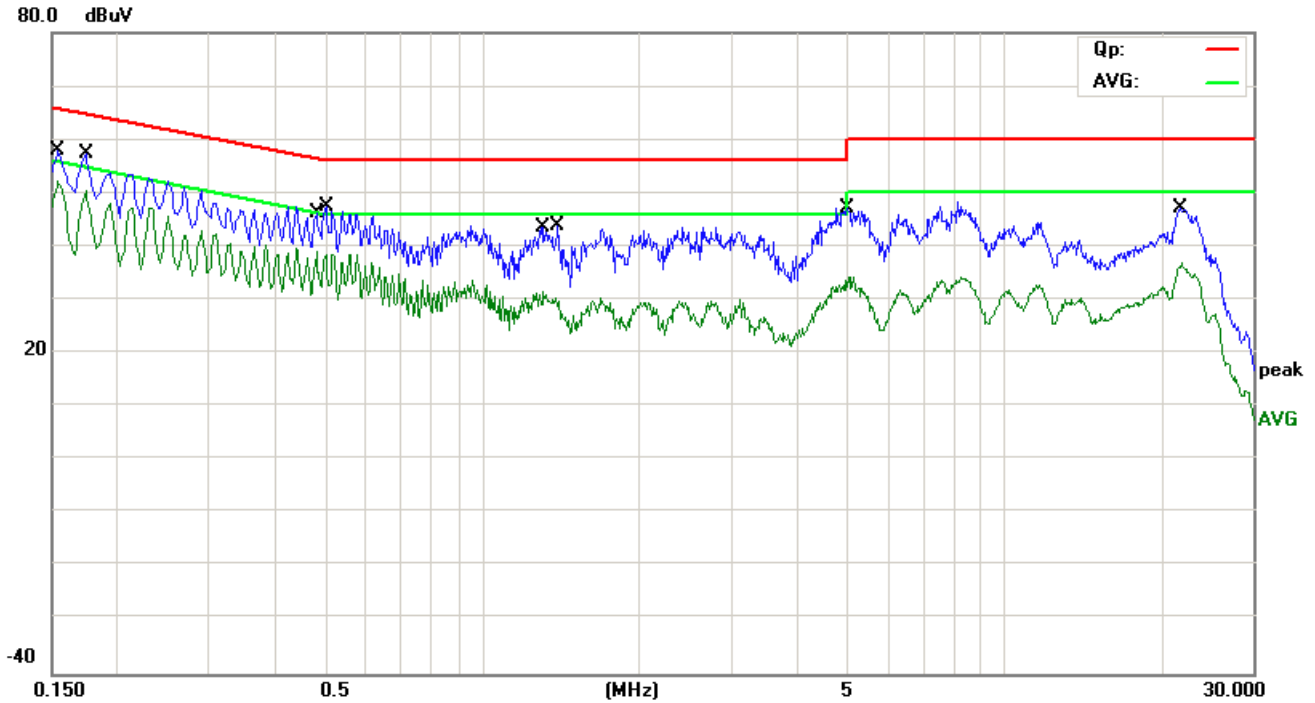

No.	Mk.	Freq.	Reading Level	Correct Factor	Measurement	Limit	Over	Detector	Comment
		MHz	dBuV	dB	dBuV	dBuV	dB		
1		0.1540	48.30	9.60	57.90	65.78	-7.88	QP	
2	*	0.1540	42.69	9.60	52.29	55.78	-3.49	AVG	
3		0.1740	47.73	9.61	57.34	64.77	-7.43	QP	
4		0.1740	40.88	9.61	50.49	54.77	-4.28	AVG	
5		0.4820	29.60	9.59	39.19	46.30	-7.11	AVG	
6		0.5020	37.95	9.59	47.54	56.00	-8.46	QP	
7		1.3100	22.07	9.60	31.67	46.00	-14.33	AVG	
8		1.3980	34.19	9.60	43.79	56.00	-12.21	QP	
9		5.0220	37.60	9.63	47.23	60.00	-12.77	QP	
10		5.0420	24.76	9.63	34.39	50.00	-15.61	AVG	
11		21.7780	37.32	9.74	47.06	60.00	-12.94	QP	
12		21.8660	27.11	9.74	36.85	50.00	-13.15	AVG	

*:Maximum data x:Over limit !:over margin

EUT:	UPS	M/N:	LEO+ 850VA
Mode:	Charging+Discharging	Phase:	N
Test by:	hzy	Power:	AC 230V/50Hz
Temperature: / Humidity	24.4°C/51.5%	Test date:	2016-07-28

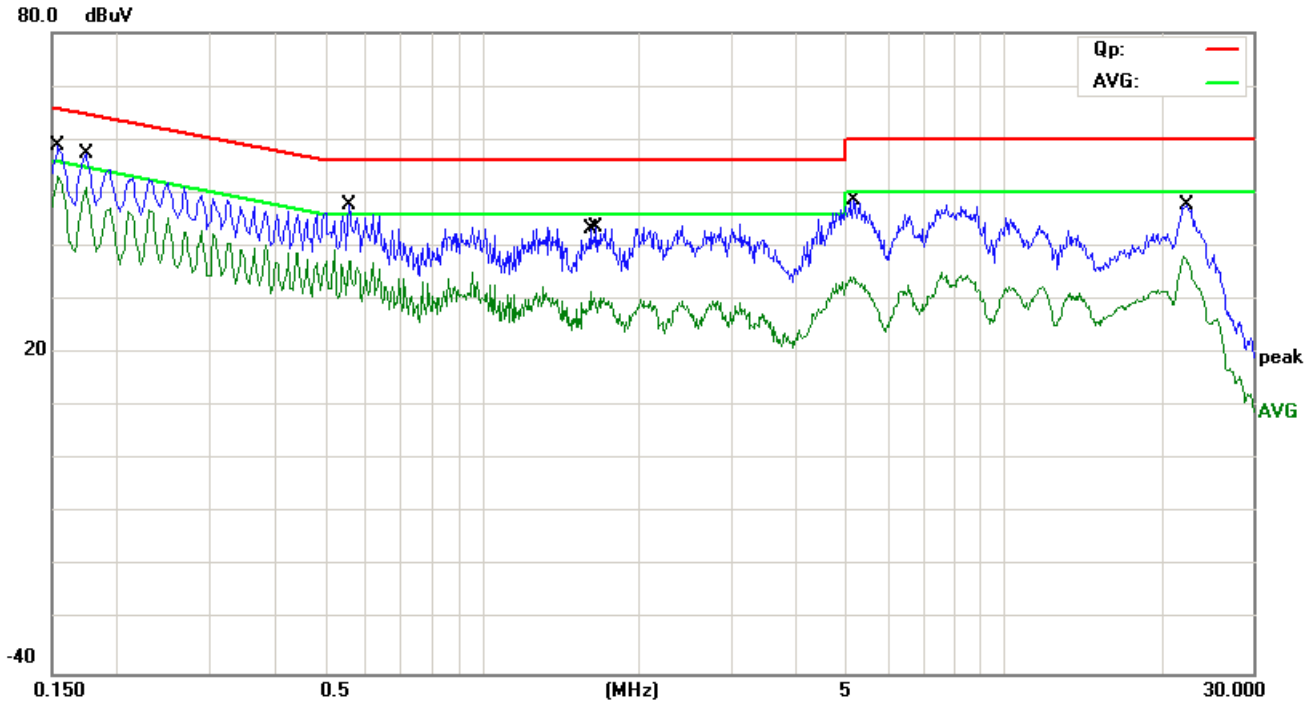

No.	Mk.	Freq. MHz	Reading Level dBuV	Correct Factor dB	Measure- ment dBuV	Limit dBuV	Over dB	Detector	Comment
1		0.1540	43.10	9.60	52.70	65.78	-13.08	QP	
2		0.1540	39.50	9.60	49.10	55.78	-6.68	AVG	
3		0.1740	47.86	9.61	57.47	64.77	-7.30	QP	
4	*	0.1740	41.59	9.61	51.20	54.77	-3.57	AVG	
5		0.5580	38.07	9.59	47.66	56.00	-8.34	QP	
6		0.5580	27.71	9.59	37.30	46.00	-8.70	AVG	
7		1.6180	22.07	9.60	31.67	46.00	-14.33	AVG	
8		1.6580	34.05	9.60	43.65	56.00	-12.35	QP	
9		5.1020	24.58	9.63	34.21	50.00	-15.79	AVG	
10		5.1660	38.90	9.63	48.53	60.00	-11.47	QP	
11		22.1020	28.28	9.74	38.02	50.00	-11.98	AVG	
12		22.5300	38.13	9.74	47.87	60.00	-12.13	QP	

*:Maximum data x:Over limit !:over margin

APPENDIX II

EUT:	UPS	M/N:	LEO+ 650VA
Mode:	Charging	Phase:	Vertical
Test by:	hzy	Power:	AC 230V/50Hz
Temperature: / Humidity	24.4°C/51.5%	Test date:	2016-07-28

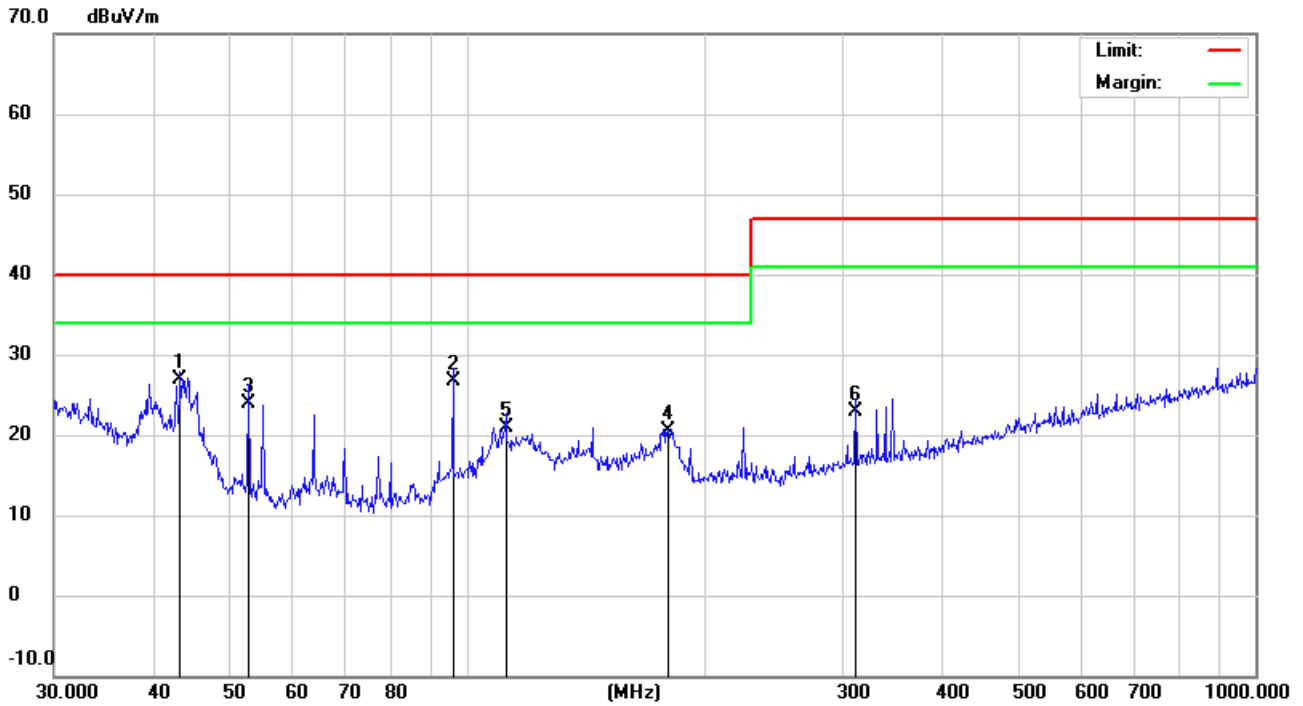

No.	Mk.	Freq.	Reading Level	Correct Factor	Measurement	Limit	Over	Antenna Height	Table Degree	
		MHz	dBuV	dB	dBuV/m	dBuV/m	dB	cm	degree	Comment
1	*	43.3534	15.40	11.59	26.99	40.00	-13.01	QP		
2		96.0985	17.70	8.94	26.64	40.00	-13.36	QP		
3		52.9453	16.00	7.95	23.95	40.00	-16.05	QP		
4		180.0164	9.00	11.60	20.60	40.00	-19.40	QP		
5		112.1304	8.70	12.15	20.85	40.00	-19.15	QP		
6		311.0866	9.20	13.71	22.91	47.00	-24.09	QP		

*:Maximum data x:Over limit !:over margin

EUT:	UPS	M/N:	LEO+ 650VA
Mode:	Charging	Phase:	Horizontal
Test by:	hzy	Power:	AC 230V/50Hz
Temperature: / Humidity	24.4°C/51.5%	Test date:	2016-07-28

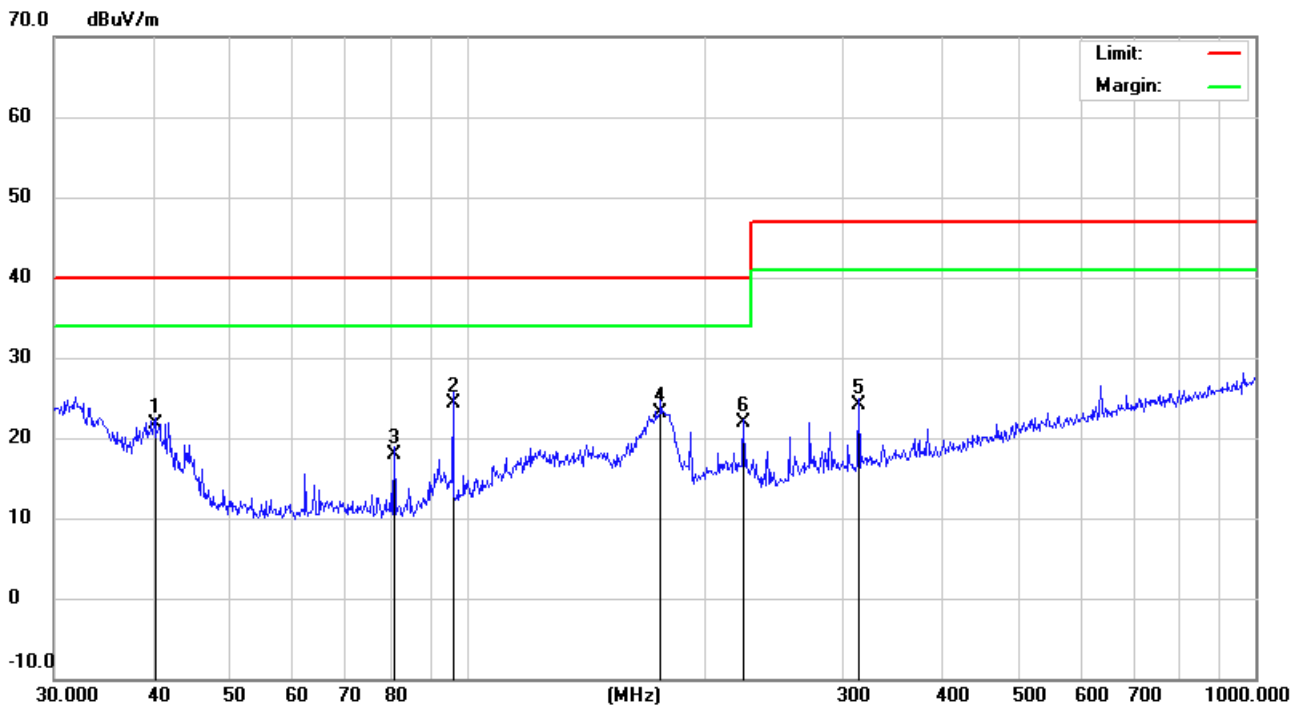

No.	Mk.	Freq. MHz	Reading Level dBuV	Correct Factor dB	Measure- ment dBuV/m	Limit dBuV/m	Over dB	Detector	Antenna Height cm	Table Degree	Comment
1		40.2756	8.00	13.62	21.62	40.00	-18.38	QP			
2	*	96.0985	15.40	8.94	24.34	40.00	-15.66	QP			
3		80.9274	9.90	8.08	17.98	40.00	-22.02	QP			
4		176.2686	11.40	11.75	23.15	40.00	-16.85	QP			
5		314.3763	10.30	13.77	24.07	47.00	-22.93	QP			
6		224.5192	10.00	12.00	22.00	40.00	-18.00	QP			

*:Maximum data x:Over limit !:over margin

EUT:	UPS	M/N:	LEO+ 650VA
Mode:	Charging+Discharging	Phase:	Vertical
Test by:	hzy	Power:	AC 230V/50Hz
Temperature: / Humidity	24.4°C/51.5%	Test date:	2016-07-28

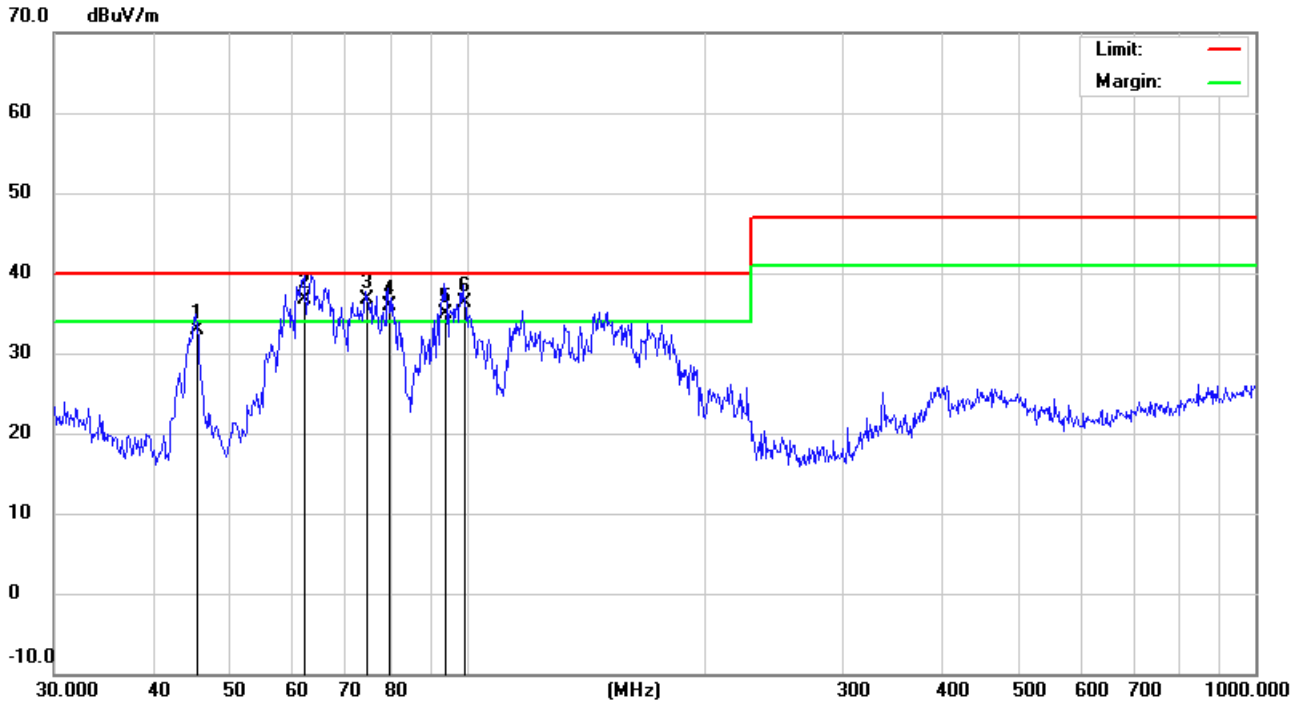

No.	Mk.	Freq.	Reading Level	Correct Factor	Measurement	Limit	Over	Antenna Height	Table Degree	
		MHz	dBuV	dB	dBuV/m	dBuV/m	dB	cm	degree	Comment
1		45.3755	22.65	10.32	32.97	40.00	-7.03			QP
2	*	62.2128	28.95	7.75	36.70	40.00	-3.30			QP
3	!	74.3955	28.41	8.21	36.62	40.00	-3.38			QP
4	!	79.5209	27.85	8.11	35.96	40.00	-4.04			QP
5	!	93.7685	26.40	8.54	34.94	40.00	-5.06			QP
6	!	99.5281	26.85	9.52	36.37	40.00	-3.63			QP

*:Maximum data x:Over limit !:over margin

EUT:	UPS	M/N:	LEO+ 650VA
Mode:	Charging+Discharging	Phase:	Horizontal
Test by:	hzy	Power:	AC 230V/50Hz
Temperature: / Humidity	24.4°C/51.5%	Test date:	2016-07-28

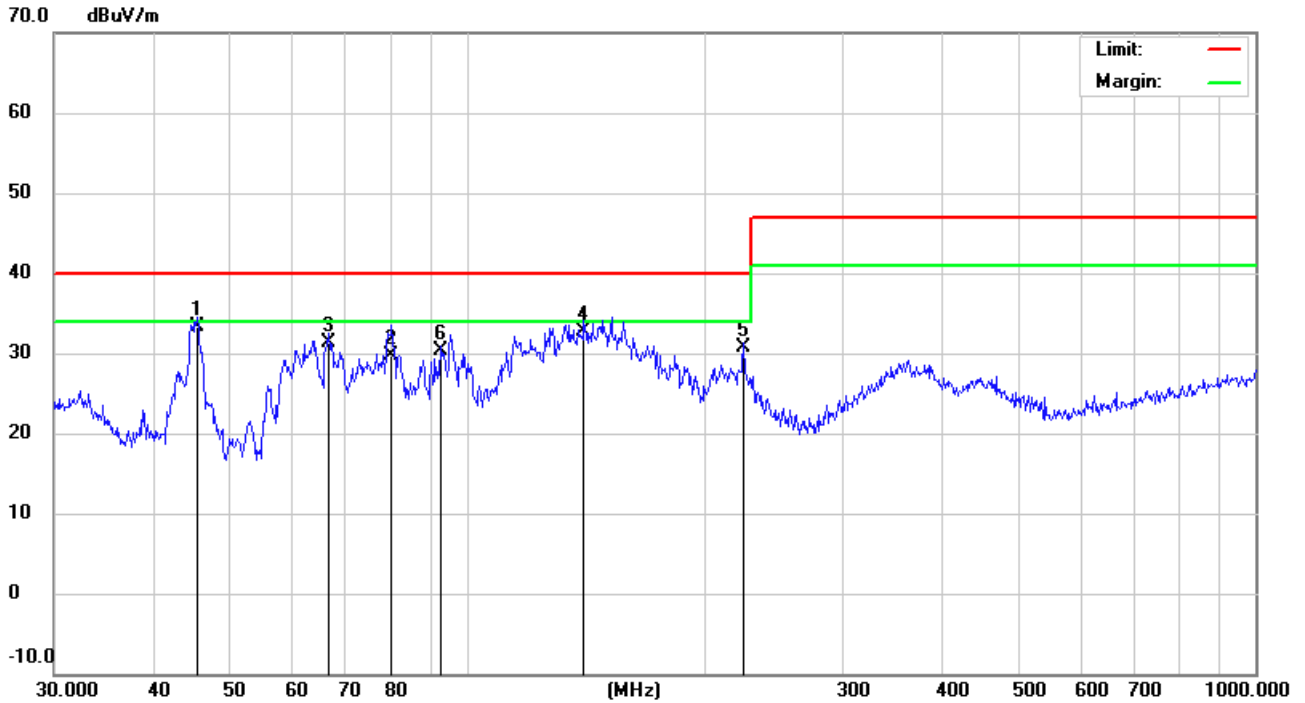

No.	Mk.	Freq. MHz	Reading Level dBuV	Correct Factor dB	Measure- ment dBuV/m	Limit dBuV/m	Over dB	Detector	Antenna Height cm	Table Degree	Comment
1	*	45.5348	23.10	10.24	33.34	40.00	-6.66	QP			
2		80.3617	21.60	8.09	29.69	40.00	-10.31	QP			
3		66.7325	23.30	8.07	31.37	40.00	-8.63	QP			
4		140.8350	19.40	13.34	32.74	40.00	-7.26	QP			
5		224.5192	18.70	12.00	30.70	40.00	-9.30	QP			
6		92.7871	22.00	8.37	30.37	40.00	-9.63	QP			

*:Maximum data x:Over limit !:over margin

EUT:	UPS	M/N:	LEO+ 650VA
Mode:	Discharging	Phase:	Vertical
Test by:	hzy	Power:	DC 12V by Battery
Temperature: / Humidity	24.4°C/51.5%	Test date:	2016-07-28

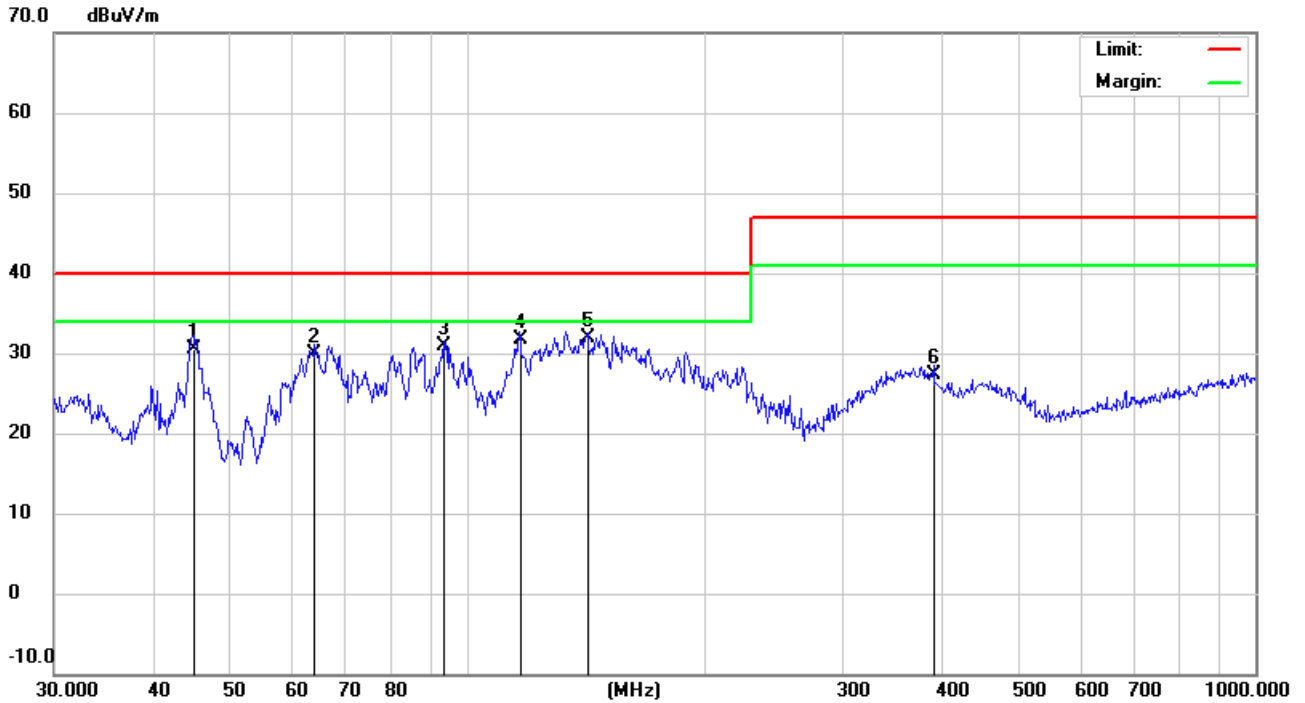

No.	Mk.	Freq.	Reading Level	Correct Factor	Measurement	Limit	Over	Antenna Height	Table Degree	
		MHz	dBuV	dB	dBuV/m	dBuV/m	dB	cm	degree	Comment
1		45.0583	20.10	10.47	30.57	40.00	-9.43	QP		
2		64.2074	22.10	7.89	29.99	40.00	-10.01	QP		
3		93.4402	22.50	8.48	30.98	40.00	-9.02	QP		
4		116.5401	18.70	13.07	31.77	40.00	-8.23	QP		
5	*	142.3243	18.60	13.24	31.84	40.00	-8.16	QP		
6		390.7226	12.10	15.22	27.32	47.00	-19.68	QP		

*:Maximum data x:Over limit !:over margin

EUT:	UPS	M/N:	LEO+ 650VA
Mode:	Discharging	Phase:	Horizontal
Test by:	hzy	Power:	DC 12V by Battery
Temperature: / Humidity	24.4°C/51.5%	Test date:	2016-07-28

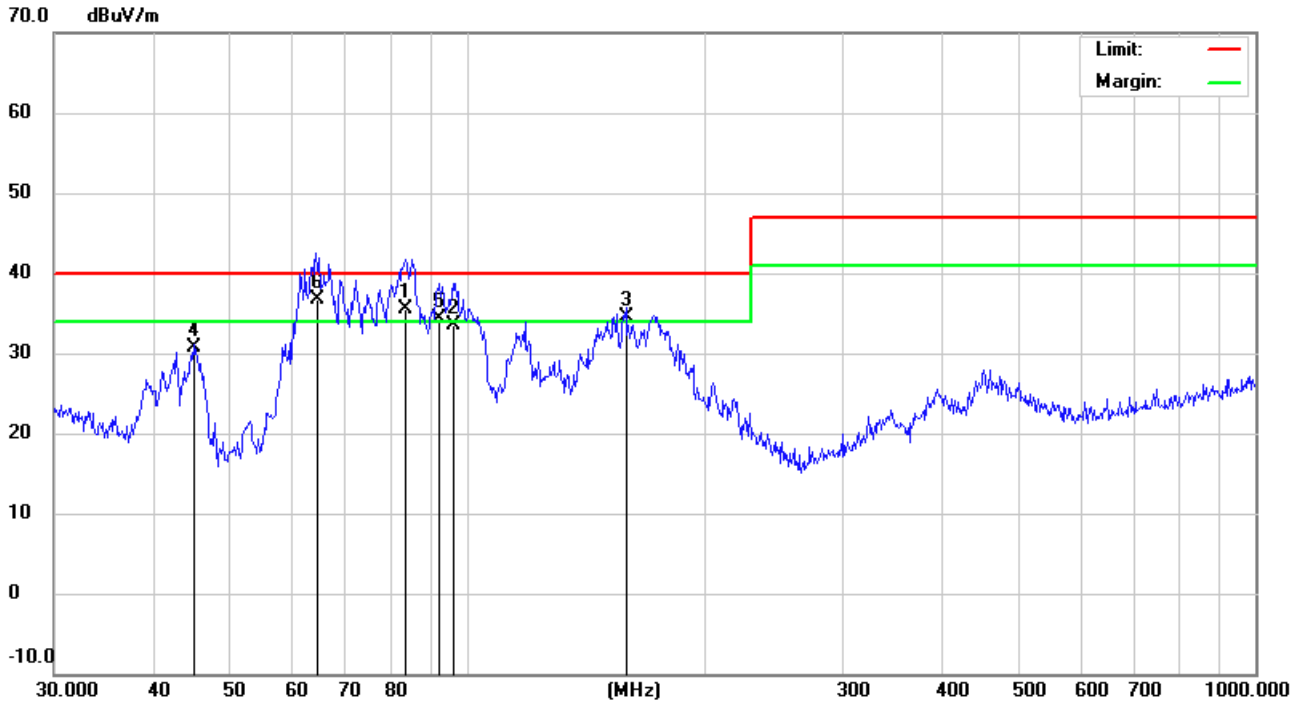

No.	Mk.	Freq. MHz	Reading Level dBuV	Correct Factor dB	Measure- ment dBuV/m	Limit dBuV/m	Over dB	Detector	Antenna Height cm	Table Degree	Comment
1	!	83.5222	27.50	8.03	35.53	40.00	-4.47	QP			
2		96.0986	24.50	8.94	33.44	40.00	-6.56	QP			
3	!	159.2251	22.10	12.33	34.43	40.00	-5.57	QP			
4		45.0583	20.30	10.47	30.77	40.00	-9.23	QP			
5	!	92.4624	26.00	8.32	34.32	40.00	-5.68	QP			
6	*	64.4331	28.80	7.91	36.71	40.00	-3.29	QP			

*:Maximum data x:Over limit !:over margin

EUT:	UPS	M/N:	LEO+ 850VA
Mode:	Charging	Phase:	Vertical
Test by:	hzy	Power:	AC 230V/50Hz
Temperature: / Humidity	24.4°C/51.5%	Test date:	2016-07-28

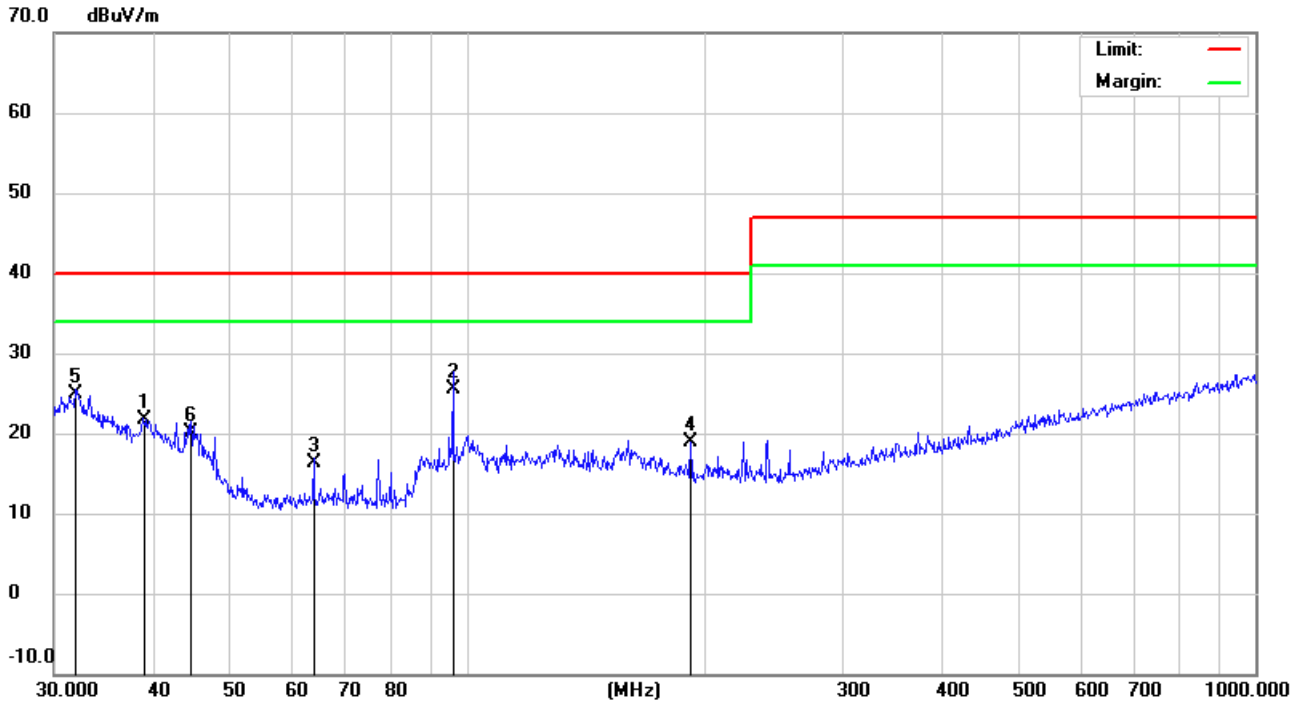

No.	Mk.	Freq. MHz	Reading Level dBuV	Correct Factor dB	Measure- ment dBuV/m	Limit dBuV/m	Over dB	Detector	Antenna Height cm	Table Degree	Comment
1		38.8878	7.10	14.62	21.72	40.00	-18.28	QP			
2	*	96.0985	16.50	8.94	25.44	40.00	-14.56	QP			
3		63.9827	8.50	7.88	16.38	40.00	-23.62	QP			
4		192.4185	7.00	11.97	18.97	40.00	-21.03	QP			
5		31.9545	5.30	19.57	24.87	40.00	-15.13	QP			
6		44.7433	9.50	10.67	20.17	40.00	-19.83	QP			

*:Maximum data x:Over limit !:over margin

EUT:	UPS	M/N:	LEO+ 850VA
Mode:	Charging	Phase:	Horizontal
Test by:	hzy	Power:	AC 230V/50Hz
Temperature: / Humidity	24.4°C/51.5%	Test date:	2016-07-28

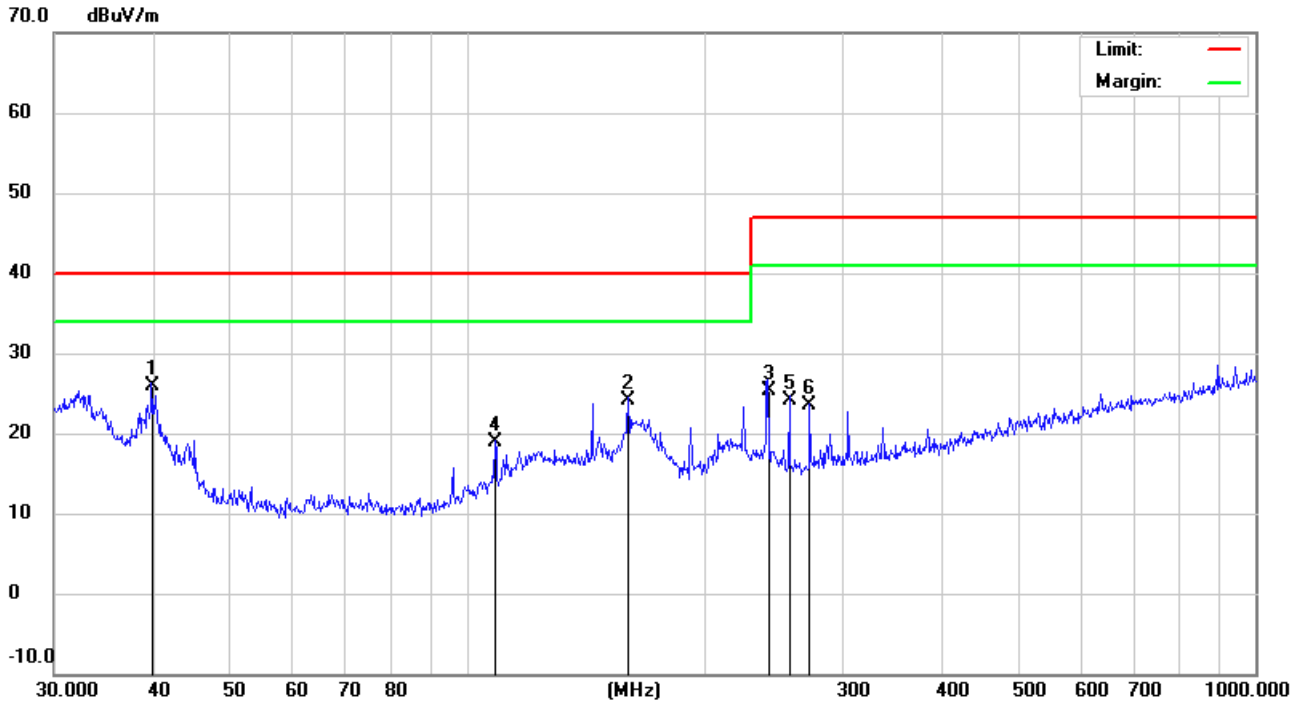

No.	Mk.	Freq. MHz	Reading Level dBuV	Correct Factor dB	Measure- ment dBuV/m	Limit dBuV/m	Over dB	Detector	Antenna Height cm	Table Degree	Comment
1	*	39.8542	12.00	13.91	25.91	40.00	-14.09	QP			
2		160.3456	11.80	12.29	24.09	40.00	-15.91	QP			
3		240.8304	13.50	11.87	25.37	47.00	-21.63	QP			
4		108.6470	7.50	11.42	18.92	40.00	-21.08	QP			
5		256.5210	12.10	12.02	24.12	47.00	-22.88	QP			
6		272.2776	10.90	12.56	23.46	47.00	-23.54	QP			

*:Maximum data x:Over limit !:over margin

EUT:	UPS	M/N:	LEO+ 850VA
Mode:	Charging+Discharging	Phase:	Vertical
Test by:	hzy	Power:	AC 230V/50Hz
Temperature: / Humidity	24.4°C/51.5%	Test date:	2016-07-28

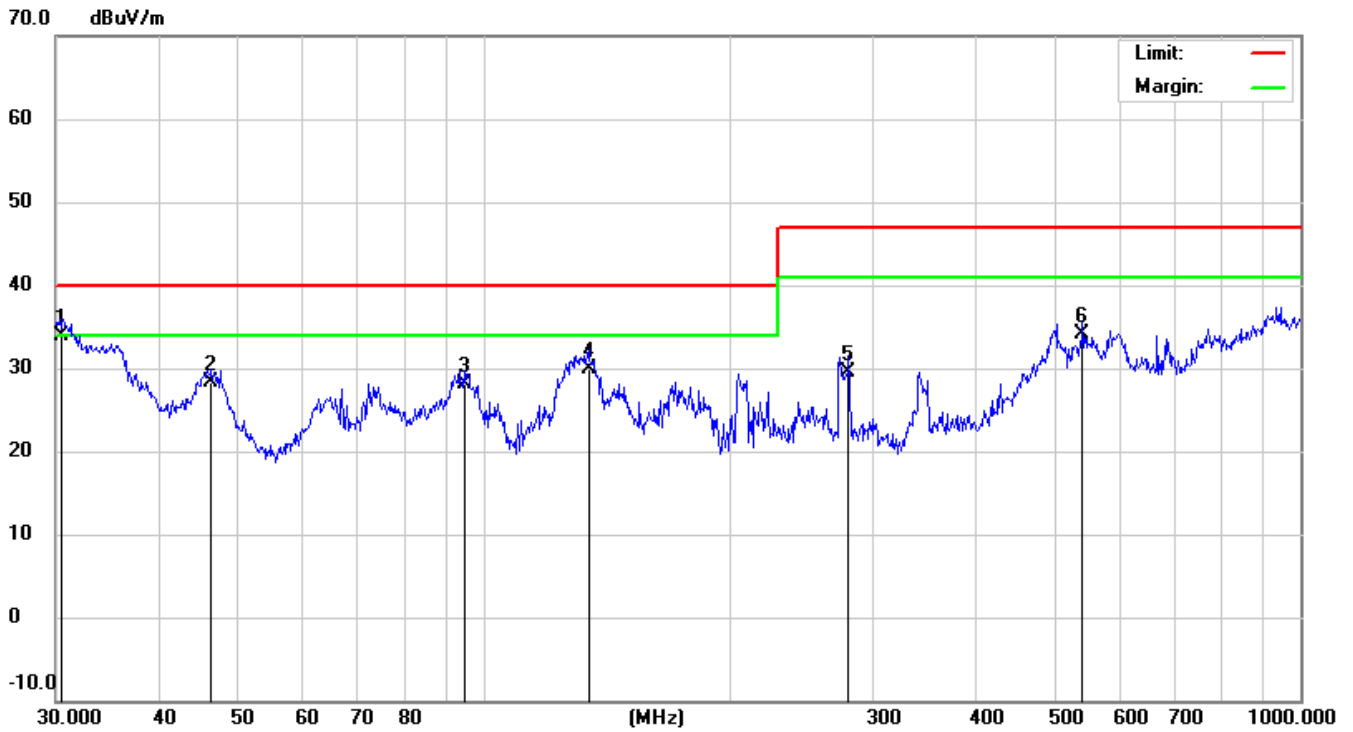

No.	Mk.	Freq. MHz	Reading Level dBuV	Correct Factor dB	Measure- ment dBuV/m	Limit dBuV/m	Over dB	Detector	Antenna Height cm	Table Degree	Comment
1	*	30.3173	13.30	20.68	33.98	40.00	-6.02	QP			
2		46.5030	18.47	9.78	28.25	40.00	-11.75	QP			
3		94.7601	16.54	11.66	28.20	40.00	-11.80	QP			
4		134.5592	13.69	16.25	29.94	40.00	-10.06	QP			
5		280.0237	14.59	14.82	29.41	47.00	-17.59	QP			
6		541.3725	11.04	23.16	34.20	47.00	-12.80	QP			

*:Maximum data x:Over limit !:over margin

EUT:	UPS	M/N:	LEO+ 850VA
Mode:	Charging+Discharging	Phase:	Horizontal
Test by:	hzy	Power:	AC 230V/50Hz
Temperature: / Humidity	24.4°C/51.5%	Test date:	2016-07-28

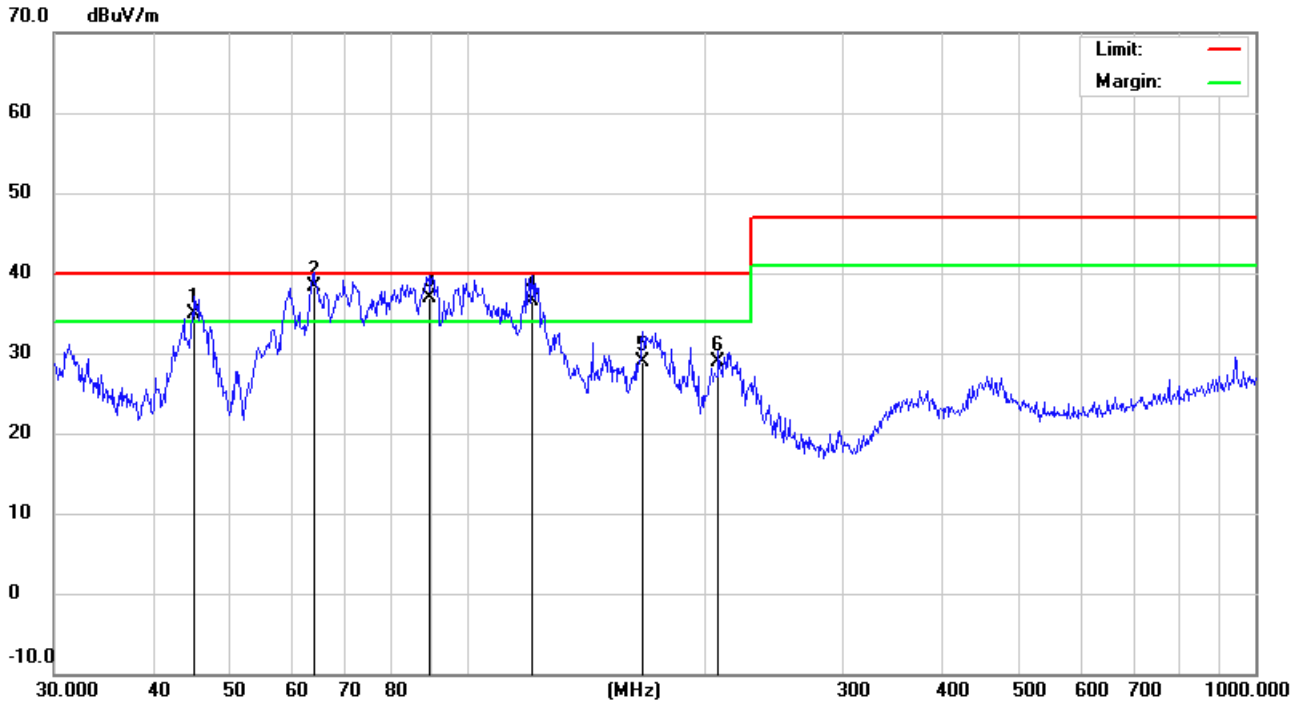

No.	Mk.	Freq. MHz	Reading Level dBuV	Correct Factor dB	Measure- ment dBuV/m	Limit dBuV/m	Over dB	Detector	Antenna Height cm	Table Degree	Comment
1	!	45.2165	24.53	10.40	34.93	40.00	-5.07	QP			
2	*	63.9827	30.52	7.88	38.40	40.00	-1.60	QP			
3	!	89.5899	28.97	7.91	36.88	40.00	-3.12	QP			
4	!	121.1231	22.68	13.84	36.52	40.00	-3.48	QP			
5	x	167.2366	16.76	12.06	28.82	40.00	-11.18	QP			
6	x	208.5801	16.74	12.13	28.87	40.00	-11.13	QP			

*:Maximum data x:Over limit !:over margin

EUT:	UPS	M/N:	LEO+ 850VA
Mode:	Discharging	Phase:	Vertical
Test by:	hzy	Power:	DC 12V by Battery
Temperature: / Humidity	24.4°C/51.5%	Test date:	2016-07-28

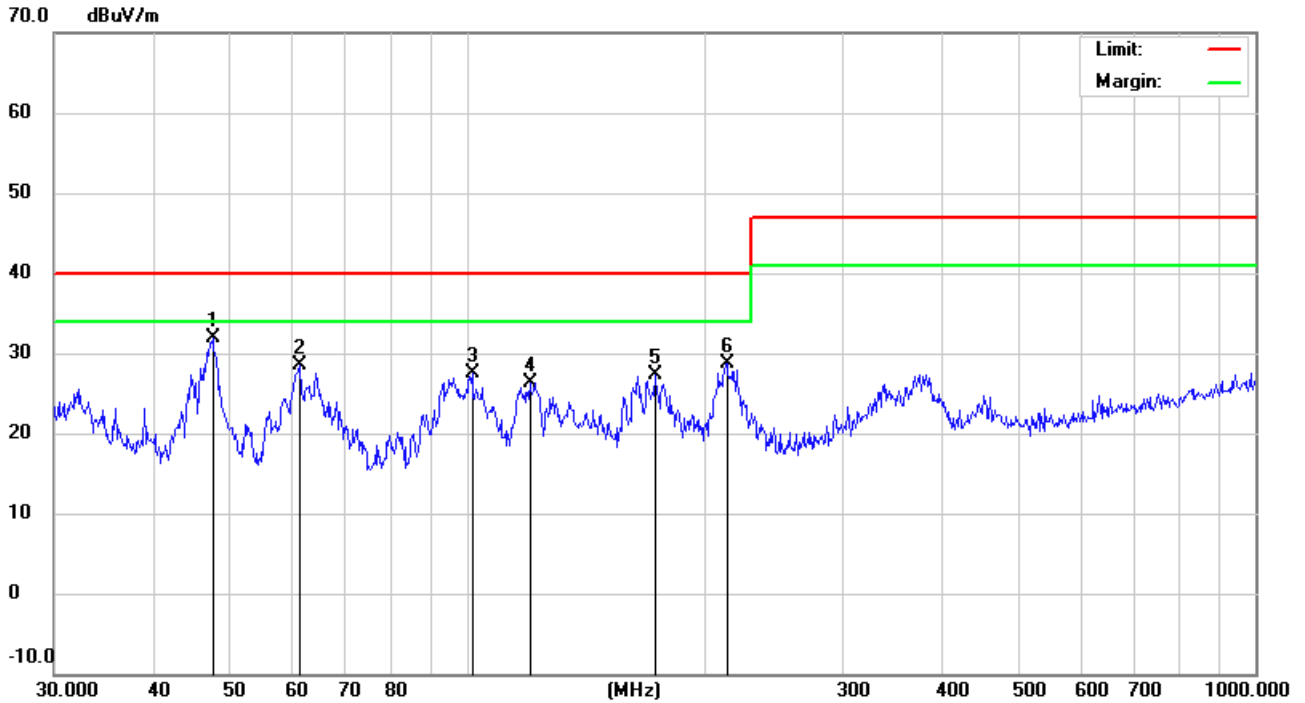

No.	Mk.	Freq. MHz	Reading Level dBuV	Correct Factor dB	Measure- ment dBuV/m	Limit dBuV/m	Over dB	Antenna Height cm	Table Degree	Detector	Comment
1	*	47.6586	22.74	9.22	31.96	40.00	-8.04			QP	
2		61.3463	20.83	7.69	28.52	40.00	-11.48			QP	
3		101.6443	17.62	9.95	27.57	40.00	-12.43			QP	
4		120.2766	12.58	13.81	26.39	40.00	-13.61			QP	
5		173.2051	15.47	11.86	27.33	40.00	-12.67			QP	
6		213.7634	16.56	12.09	28.65	40.00	-11.35			QP	

*:Maximum data x:Over limit !:over margin

EUT:	UPS	M/N:	LEO+ 850VA
Mode:	Discharging	Phase:	Horizontal
Test by:	hzy	Power:	DC 12V by Battery
Temperature: / Humidity	24.4°C/51.5%	Test date:	2016-07-28

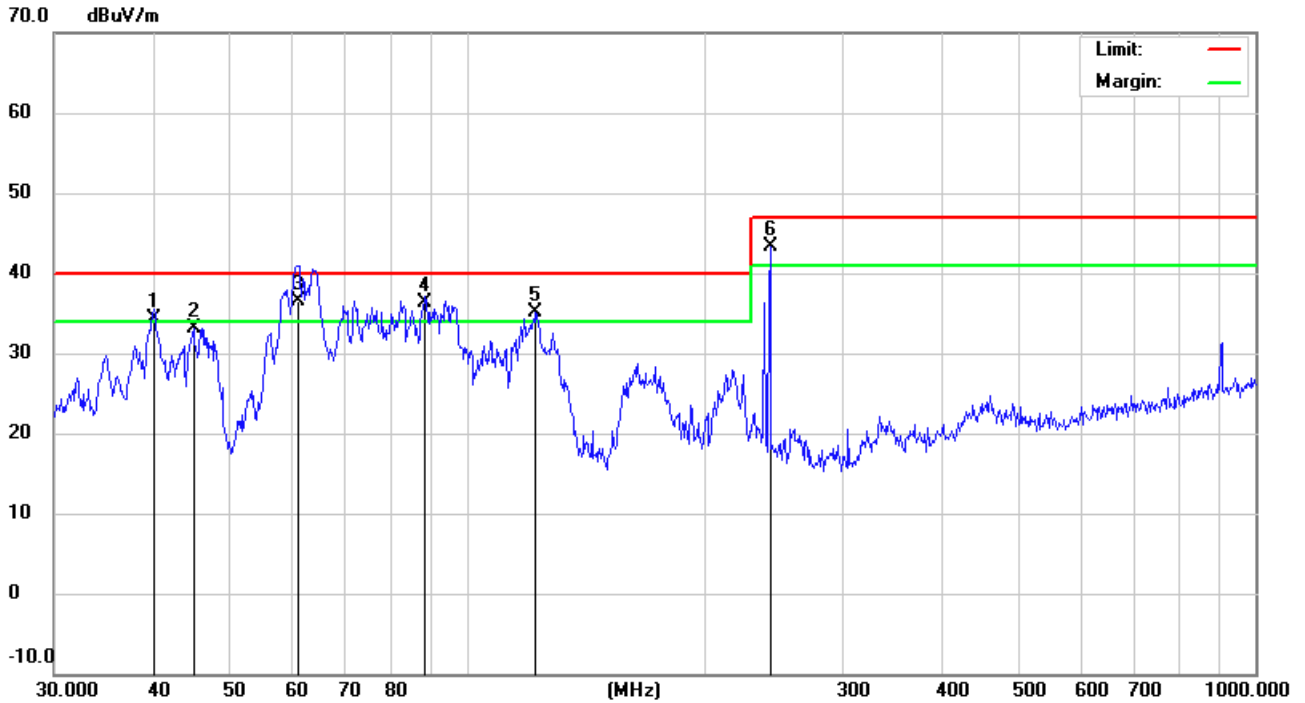

No.	Mk.	Freq. MHz	Reading Level dBuV	Correct Factor dB	Measure- ment dBuV/m	Limit dBuV/m	Over dB	Detector	Antenna Height cm	Table Degree	Comment
1	!	40.1347	20.65	13.71	34.36	40.00	-5.64	QP			
2		45.0583	22.72	10.47	33.19	40.00	-6.81	QP			
3	*	60.9176	28.76	7.66	36.42	40.00	-3.58	QP			
4	!	88.6524	28.46	7.93	36.39	40.00	-3.61	QP			
5	!	122.4040	21.19	13.90	35.09	40.00	-4.91	QP			
6	!	242.5253	31.40	11.86	43.26	47.00	-3.74	QP			

*:Maximum data x:Over limit !:over margin

APPENDIX III
(Photos of the EUT)

Figure 1((LEO+ 850VA)
General Appearance of the EUT



Figure 2((LEO+ 650VA)
General Appearance of the EUT



Figure 3
Inside of the EUT

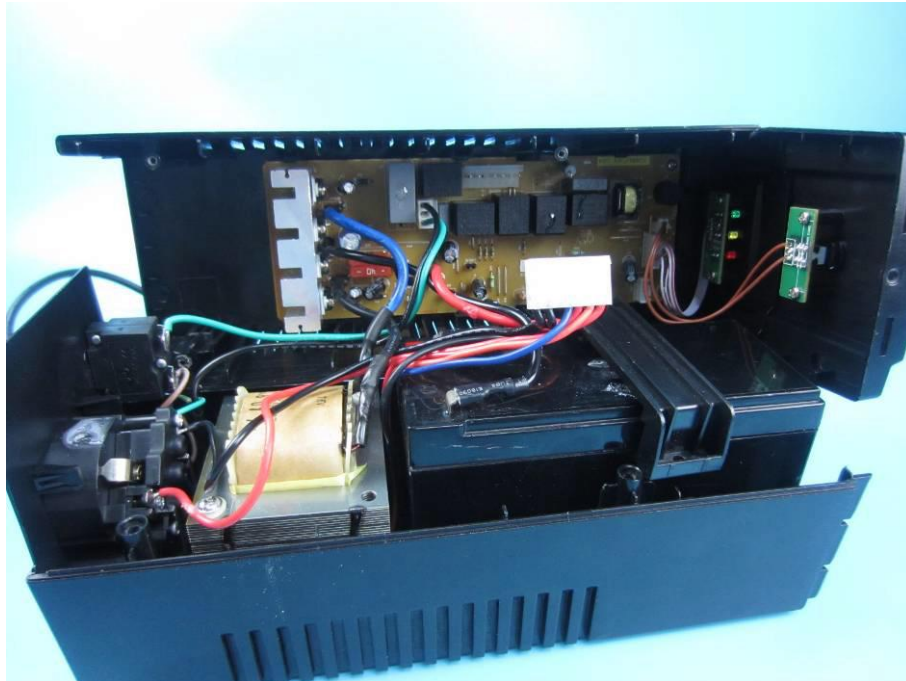

Figure 4
Components Side of the PCB

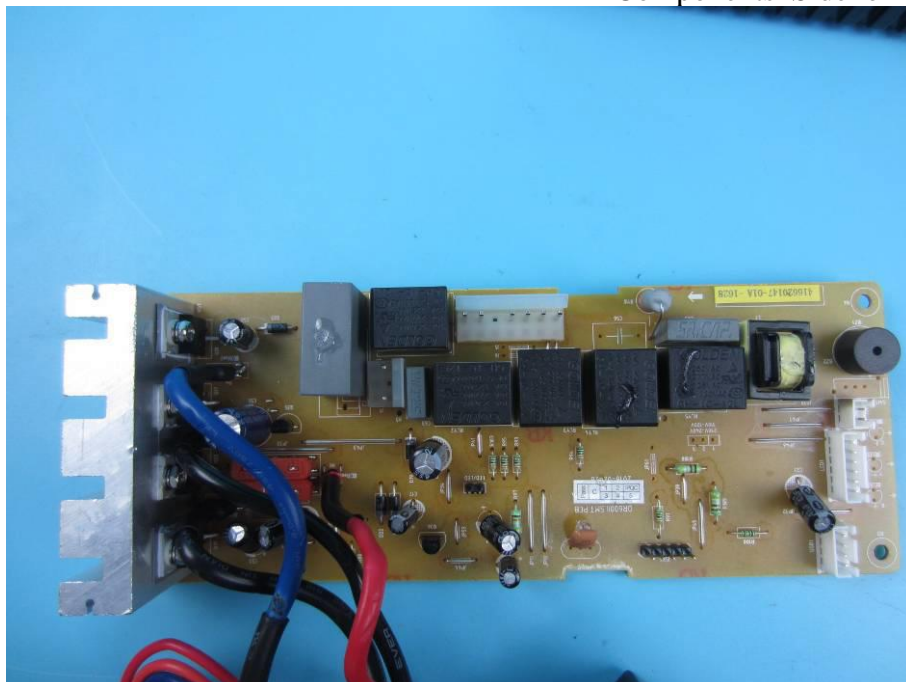

Figure 5
Components Side of the PCB

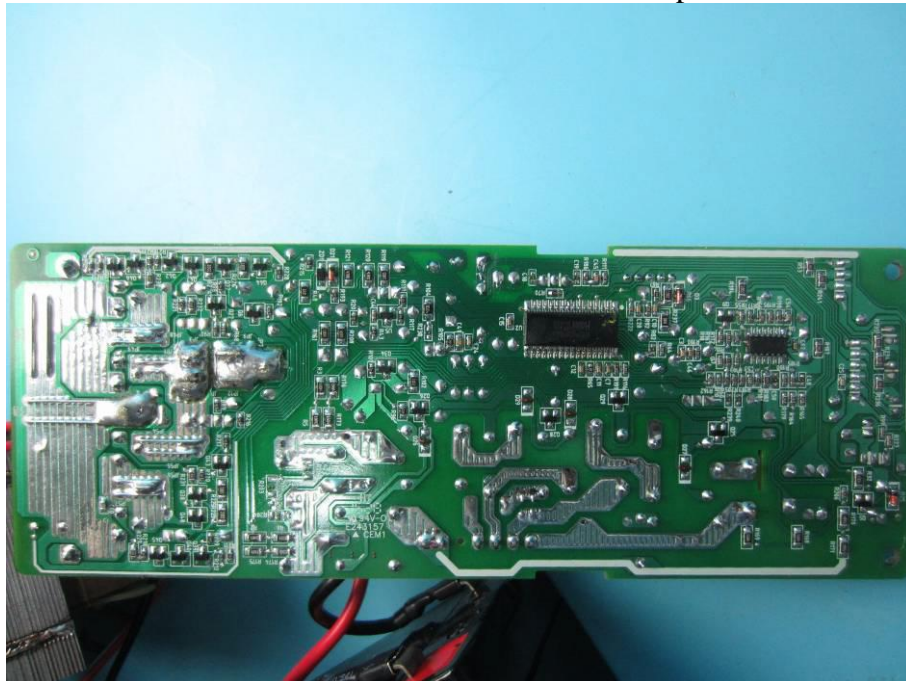

Figure 6
Battery



Figure 7
Inside of the EUT

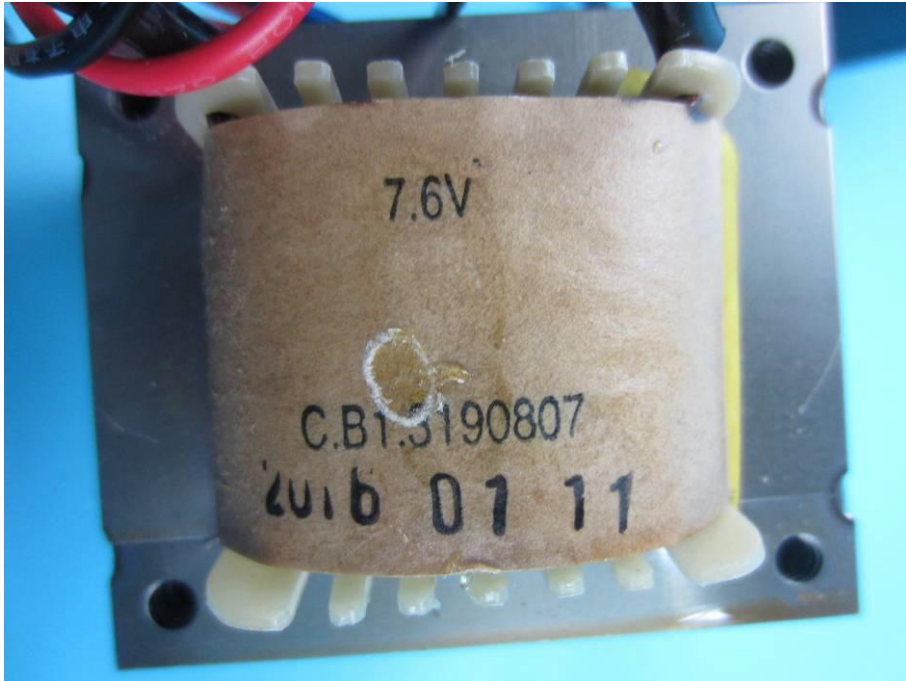

Figure 8
Inside of the EUT

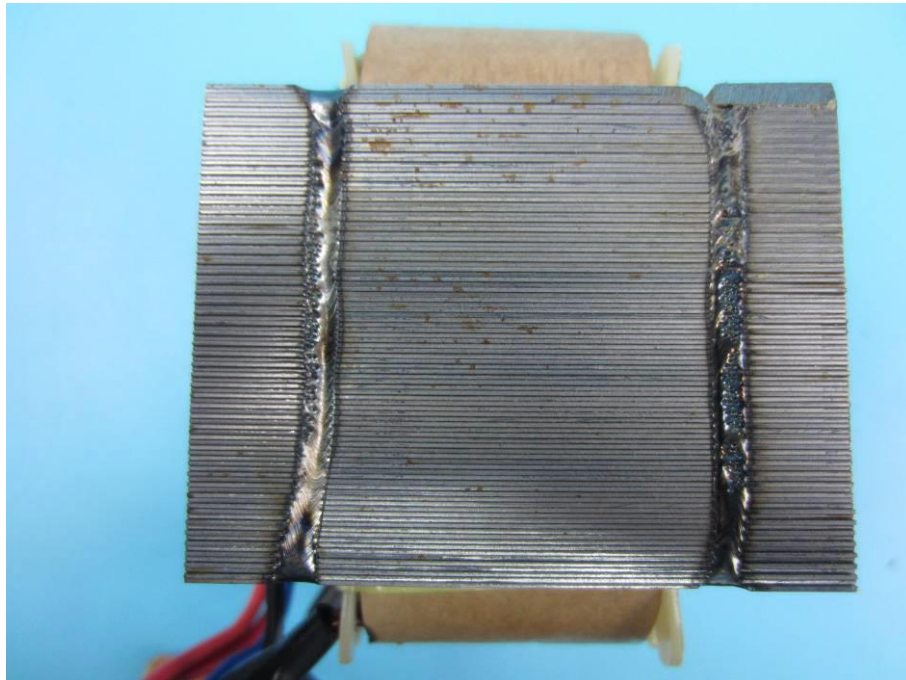

Figure 9
Inside of the EUT

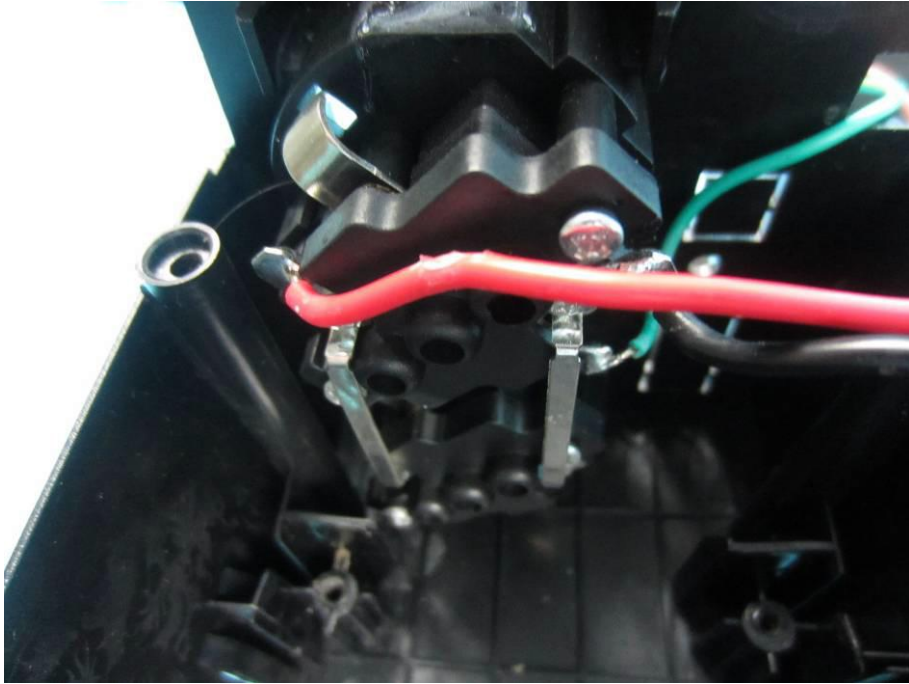

Figure 10
Inside of the EUT



Figure 11
Inside of the EUT



Figure 12
Components Side of the PCB

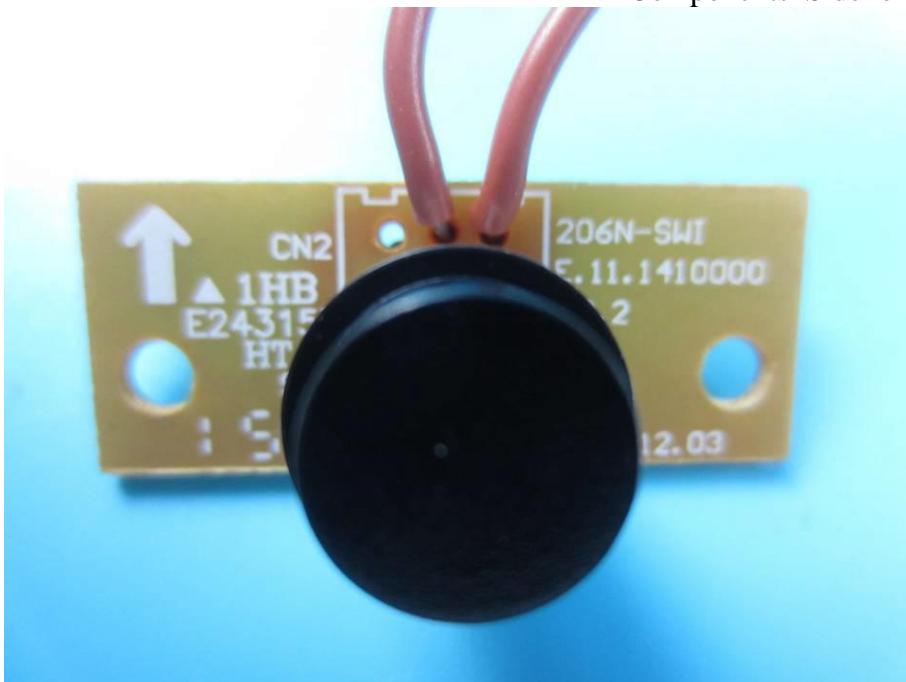

Figure 13
Components Side of the PCB

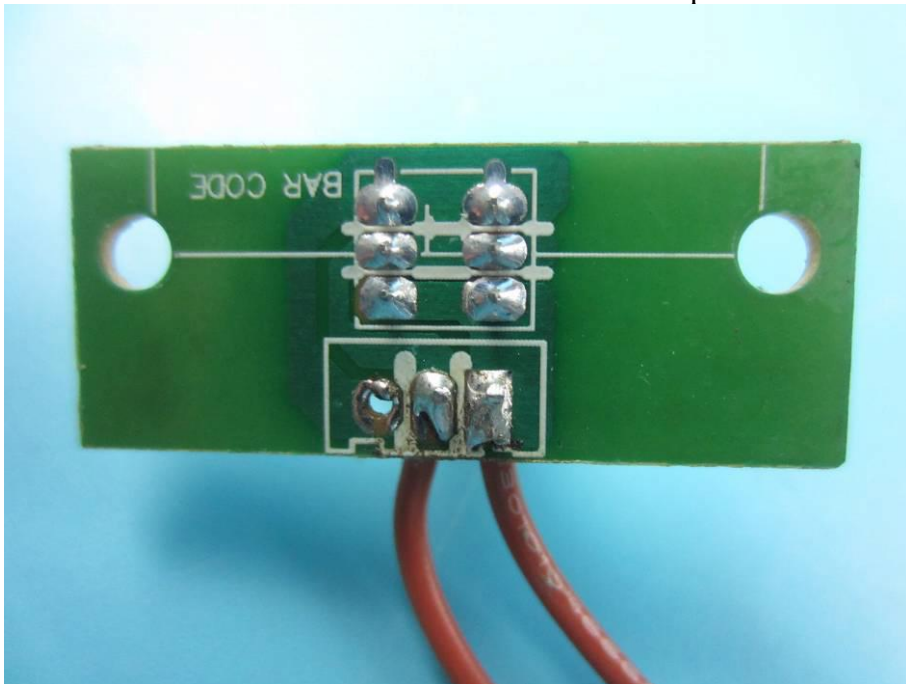

Figure 14
Components Side of the PCB

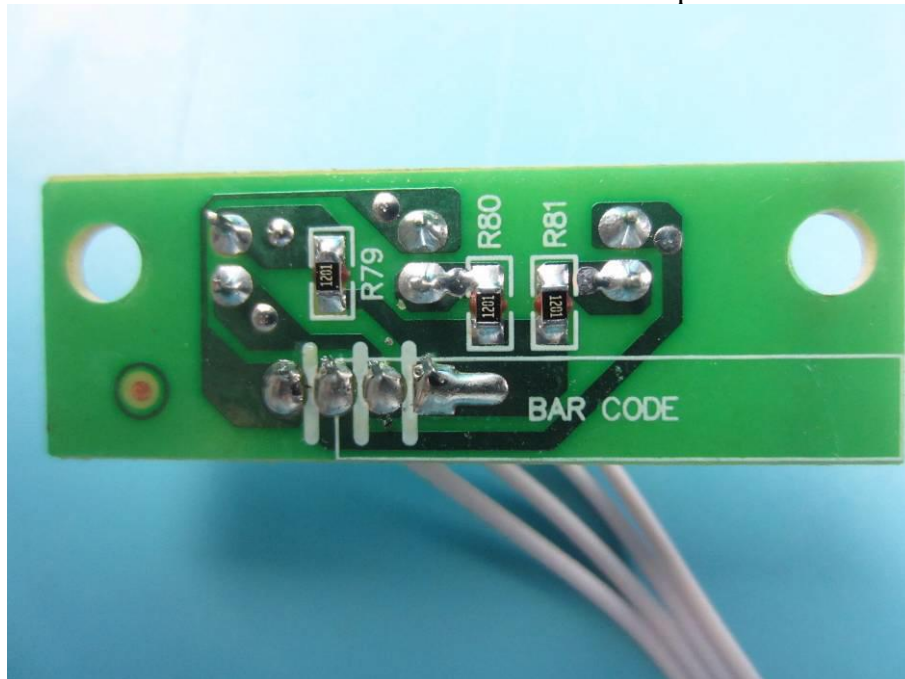

Figure 15
Components Side of the PCB

