



# **TEOS+ 300RT**

**10-15-20-30 kVA**

**3 Phase In - 3 Phase Out**

**USER MANUAL**



---

# Preface

## Usage

The manual contains information on installing, using, operation and maintenance of the UPS. Please carefully read this manual prior to installation.

## Users

Technical Support Engineer  
Maintenance Engineer

## Note

Our company is providing a full range of technical support and services. Customer can contact our local office or customer service center for help.

The manual will update irregularly, due to the product upgrading or other reasons.

Unless otherwise agreed, the manual is only used as guide for users and any statements or information contained in this manual make no warranty expressed or implied.

# Contents

1. Important Safety Precautions .....	6
General Information .....	6
UPS Safety .....	6
Battery Safety .....	2
Description of Symbols .....	3
Disposal and Recycling .....	3
2. Product Introduction .....	4
2.2 System Configuration .....	4
2.3 Operation Mode .....	4
2.3.1 Normal Mode .....	4
2.3.2 Battery Mode .....	5
2.3.3 Bypass Mode .....	5
2.3.4 Maintenance Mode (Manual Bypass) .....	6
2.3.5 ECO Mode .....	6
2.3.6 Auto-restart Mode .....	7
2.3.7 Frequency Converter Mode .....	7
2.3.8 Self Aging Mode .....	7
3.6.3 Circuit Breaker .....	16
3.6.4 Connecting Power Cables .....	16
History records .....	27
4.2.7 Control .....	27
On-Off .....	27
Maintenance .....	28
4.2.8 Settings Common settings .....	28
Communication settings .....	29
Dry contact settings .....	29
Rate parameters .....	30
Advanced parameters .....	31
Battery parameters .....	32
Warranty parameters .....	33
4.3 Event List .....	34
5. Operations .....	38
5.1 UPS Start-up .....	38
5.1.1 Start from Normal Mode .....	38
5.1.2 Start from Battery .....	38
5.2 Procedure for Switching between Operation Modes .....	39
5.2.1 Switching the UPS into Battery Mode from Normal Mode .....	39
5.2.2 Switching the UPS into Bypass Mode from Normal Mode .....	39
5.2.3 Switching the UPS into Normal Mode from Bypass Mode .....	39
5.2.4 Switching the UPS into Maintenance Bypass Mode from Normal Mode .....	39
5.2.5 Switching the UPS into Normal Mode from Maintenance Bypass Mode .....	40

5.3	Battery Maintenance .....	40
5.4	EPO.....	41
5.5	Installation of Parallel Operation System.....	42
5.5.1	Parallel system diagram.....	42
5.5.2	Parallel system setting Parallel system connection .....	43
	Parallel system software setting .....	43
6.	Maintenance.....	45
6.1	Precautions .....	45
6.2	Instruction for Maintaining UPS.....	45
6.3	Instruction for Maintaining Battery string.....	45
7.	Product Specification.....	47
7.1	Applicable Standards .....	47
7.2	Declaration of Safety conformity and CE marking .....	47
7.3	Environmental Characteristics .....	47
7.4	Mechanical Characteristic .....	48
7.5	Electrical Characteristics .....	48
8.	Software Download & Installation.....	50
	(Only for the model with communication port) .....	50

---

# Important Safety Precautions

## General Information

- Please read the "safety precautions" carefully before installing and using this product to ensure correct and safe installation and use. Please keep this manual properly.
- UPS must be installed, tested and maintained by an engineer authorized by the manufacturer or its agent, otherwise it is possible to endanger personal safety and cause equipment failure. The damage to UPS caused thereon is excluded from the warranty.
- Under no circumstances shall equipment structure or components be dismantled or changed without the manufacturer's permission, otherwise the damage to UPS caused thereby shall not be covered by the warranty.
- Local regulations and laws shall be followed when using equipment. The safety precautions in the manual only supplement the local safety regulations.
- Due to product version upgrade or other reasons, the content of this document will be updated from time to time. Unless otherwise agreed, this document is used only as a guide, and all statements, information and recommendations in this document do not constitute any warranty, express or implied.

## UPS Safety

- Before installing the equipment, wear insulating protective clothing, use insulating appliances, and remove conductive objects such as jewelry and watches to avoid electric shock or burns.
- The operating environment has a certain impact on the service life and reliability of UPS. The environmental requirements set in the manual must be followed when using and storing the equipment.
- Avoid using the equipment in direct sunlight, rain, or in environments with electrified dust.
- When placing UPS, maintain a safe distance around it to ensure ventilation. During operation of the system, do not block the vent.
- Do not allow liquids or other foreign objects to enter into the UPS cabinet or cabinet.
- Before using UPS, check whether the local distribution characteristics are consistent with the information of the product nameplate.
- As UPS is a large leakage current device, it is not recommended to install breakers with leakage protection function.
- Before connecting UPS, please further confirm whether the switch connecting the power supply of the UPS mains input/bypass power supply and the mains power are disconnected.
- When it is required to move or rewire UPS, make sure to disconnect AC input power supply, battery and other inputs, and UPS is fully powered down (more than 5min) before carrying out the corresponding operation, otherwise there may still be power in the port and inside of the equipment, and it is possible to cause a risk of electric shock.
- Before powering on, please confirm the correct grounding, and check wire

---

connection and battery polarity to ensure correct connection. In order to ensure personal safety and the normal use of UPS, UPS shall be reliably grounded before use.

- UPS can be used for resistive and capacitive (such as computers), resistive and micro inductive load, not for pure capacitive and inductive load (such as motors, air conditioners and copiers) and half wave rectifier load.
- When cleaning the machine, please wipe it with a dry object. Under no circumstances shall water be used to clean electrical parts inside or outside the cabinet.
- After completion of maintenance operations, check immediately to ensure that no tools or other items are left in the cabinet.
- In case of fire, please use dry powder extinguisher correctly for extinguishment. There is a danger of electric shock if liquid fire extinguishers are used.
- Do not close the breaker before the UPS installation is completed. Do not power on UPS without the permission of a qualified electrician.





### **Battery Safety**

- Battery installation and maintenance shall only be performed by personnel with battery expertise.
- There is danger of electric shock and short circuit current in the battery. In order to avoid safety accidents, when installing or replacing the battery, please pay attention to the following matters: do not wear jewelry and watches and other conductive objects; use special insulation tools; use facial protection; wear protective insulating clothing; do not turn the battery upside down or tilt it; disconnect the input breaker of the battery.
- The installation environment of the battery must be far away from the hot area, and it is not allowed to use or keep the battery near the fire source. The battery or battery strings cannot be processed by fire, otherwise it is possible cause personal injury due to explosion.
- Environmental factors impact battery life. Elevated ambient temperatures, poor quality utility power, and frequent short duration discharges will shorten battery life.
- The batteries should be regularly replaced to ensure the normal operation of UPS and sufficient backup time.
- Do not use a battery that is not approved by the supplier, as it may adversely affect the operation of the system. Use of a non supplier approved battery will void the manufacturer warranty.
- Check the screws of the connecting parts of the battery regularly to make sure they are tight and not loose. If the screws become loose parts, they must be tightened immediately.
- Please do not short the positive and negative terminals of the battery, Otherwise it is possible to cause electric shock or fire.
- Do not touch the wiring terminal of the battery. The battery circuit is not isolated from the input voltage circuit, and there will be a high voltage hazard between the battery terminal and the ground.
- Do not open or damage the battery, otherwise it is possible to cause short circuit and battery leakage and the electrolyte in the battery may cause damage to the



skin and eyes. In case of exposure into the electrolyte, wash immediately with plenty of water and go to the hospital for examination.

## Description of Symbols

The following symbols used herein have the following meaning.

Symbols	Description
 <b>DANGER</b>	It is used to warn of emergency and dangerous situations which may lead to death or serious bodily injury if not avoided.
 <b>WARNING</b>	It is used to warn of potential dangerous situations which will lead to a certain degree of personal injury if not avoided.
 <b>CAUTION</b>	It is used to transmit the safety warning information of equipment or environmental, which may lead to equipment damage, data loss, equipment performance degradation or other unpredictable results if not avoided.
 <b>NOTICE</b>	It is used for further detailed description of the things, highlighting important/critical information, etc.

## Disposal and Recycling

 <b>WARNING</b>	<ul style="list-style-type: none"> <li>✧ Dispose of used battery according to local instructions</li> </ul>
	<ul style="list-style-type: none"> <li>✧ This symbol means that used electrical and electronic equipment (WEEE) should not be mixed with general household waste. If you want to dispose of this product, please contact your local authorities or your dealer and ask for the correct disposal method.</li> <li>✧ Correct disposal of this product will help save valuable resources and prevent possible adverse effects on human health and the environment that could result from improper disposal.</li> </ul>



---

## 2. Product Introduction

### 2.1 Introduction

The UPS supplies stable and uninterrupted power for the important load. It can eliminate the power supply surge, instantaneous high/low voltage, harmonic and frequency offset pollution, to provide high quality electrical energy to costumers.

### 2.2 System Configuration

The Tower UPS is configured by the following part: Rectifier, Charger, Inverter, Static Switch and Manual Bypass Switch. One or several battery strings should be installed to provide backup energy once the utility fails. The UPS structure is shown in Fig. 2-1.

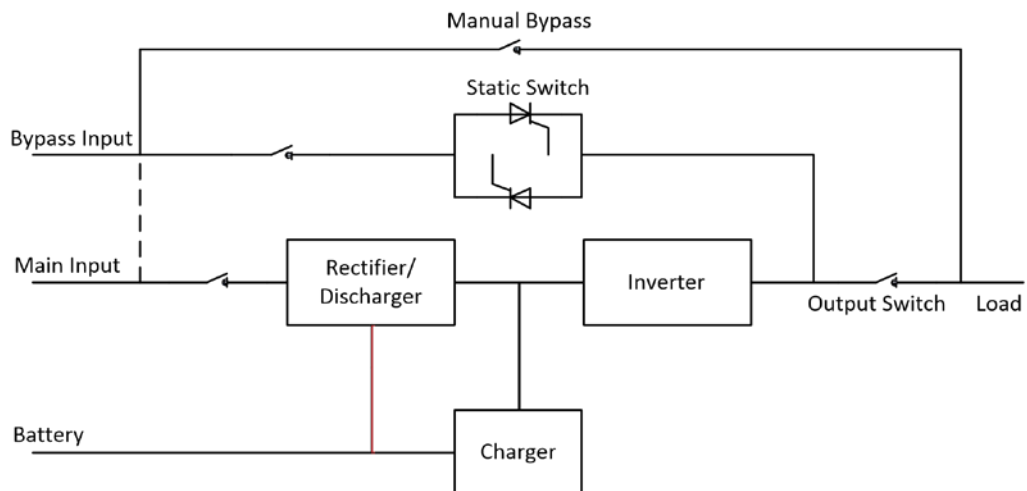

Fig. 2-1 UPS Configuration

### 2.3 Operation Mode

The UPS is an on-line, double-conversion UPS that permits operation in the following modes:

- Normal mode
- Battery mode
- Bypass mode
- Maintenance mode (manual bypass)
- ECO mode
- Auto-restart mode
- Frequency Converter mode
- Self Aging Mode

#### 2.3.1 Normal Mode

The inverter of power modules continuously supply the critical AC load. Therectifier/charger derives power from the AC mains input source and supplies DC power to the inverter while simultaneously FLOAT or BOOST charging its associated backup battery.

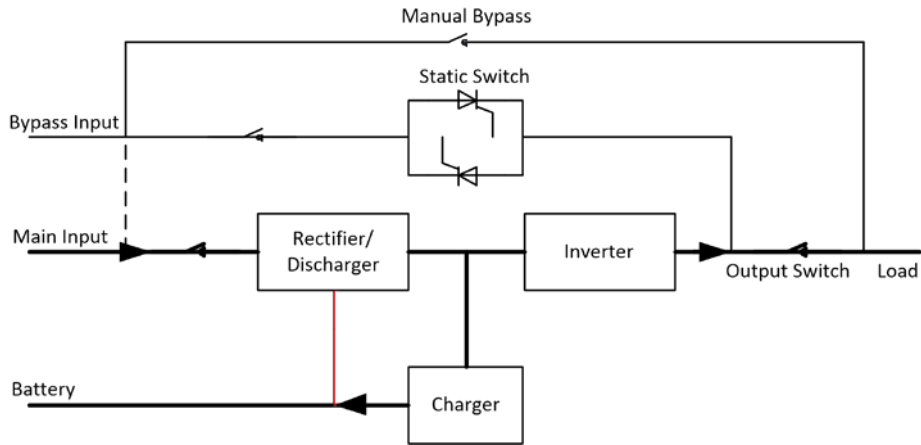

Fig 2-2 Normal mode operation diagram

### 2.3.2 Battery Mode

Upon failure of the AC mains input power, the inverter of power modules, which obtain power from the battery, supply the critical AC load. There is no interruption in power to the critical load upon failure. After restoration of the AC mains input power, the “Normal mode” operation will continue automatically without the necessity of user intervention.

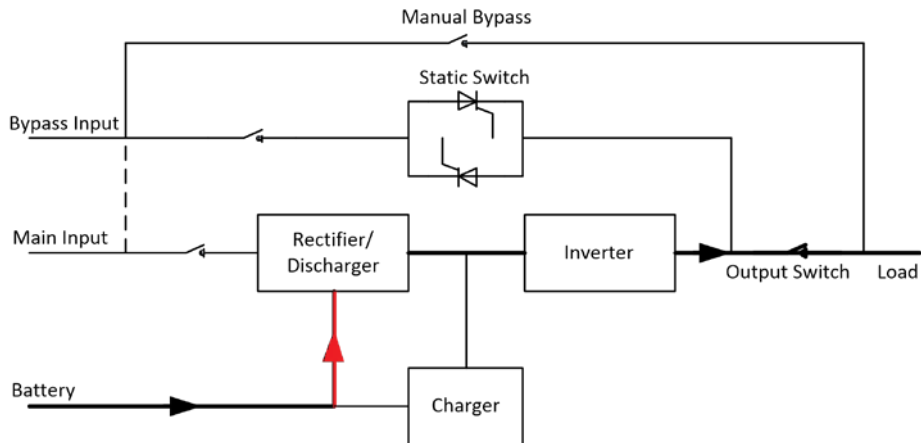

Fig 2-3 Battery mode operation diagram

#### Note

With the function of Battery cold start, the UPS may start without utility. See more detail in section 5.1.2.

### 2.3.3 Bypass Mode

If the inverter overload capacity is exceeded under Normal mode, or if the inverter becomes unavailable for any reason, the static transfer switch will perform a transfer of the load from the inverter to the bypass source, with no interruption in power to the critical AC load. Should the inverter be asynchronous with the bypass, the static switch will perform a transfer of the load from the inverter to the bypass with power interruption to the load. This is to avoid large cross currents due to the paralleling of unsynchronized AC sources. This interruption is programmable but typically set to be less than 3/4 of an electrical cycle, e.g., less than 15ms (50Hz) or less than 12.5ms (60Hz). The action of transfer/re-transfer can also be done by the command through monitor.

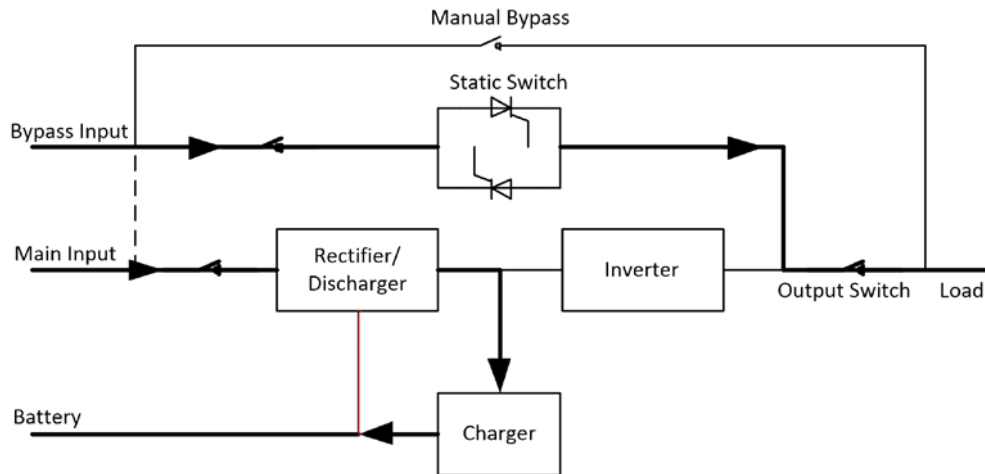

Fig. 2-4 Bypass mode operation diagram

### 2.3.4 Maintenance Mode (Manual Bypass)

A manual bypass switch is available to ensure continuity of supply to the critical load when the UPS becomes unavailable e.g. during a maintenance procedure. (See Fig.2-5).

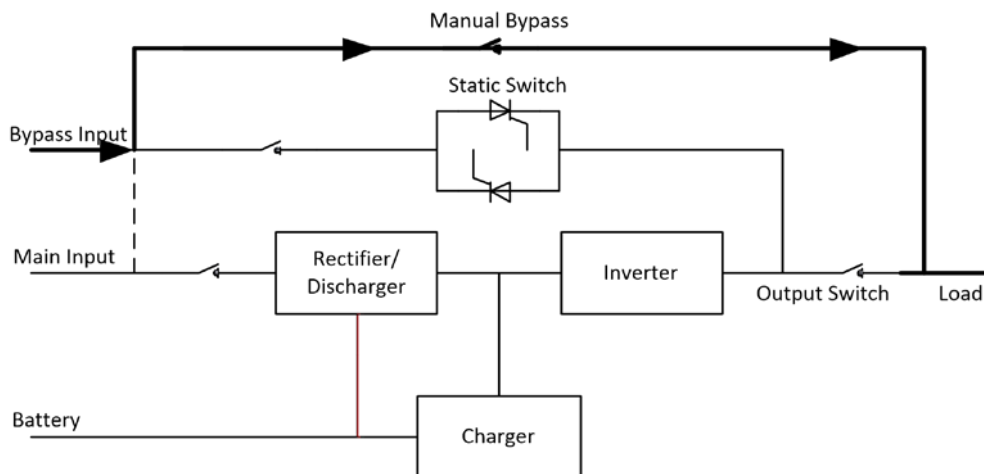

Fig. 2-5 Maintenance mode operation diagram



### **Danger**

During Maintenance mode, dangerous voltages are present on the terminal of input, output and neutral, even with the LCD turned off.

### 2.3.5 ECO Mode

To improve system efficiency, UPS rack system works in Bypass mode at normal time, and inverter is standby. When the utility fails, The UPS transfers to Battery Mode and the inverter powers the loads.

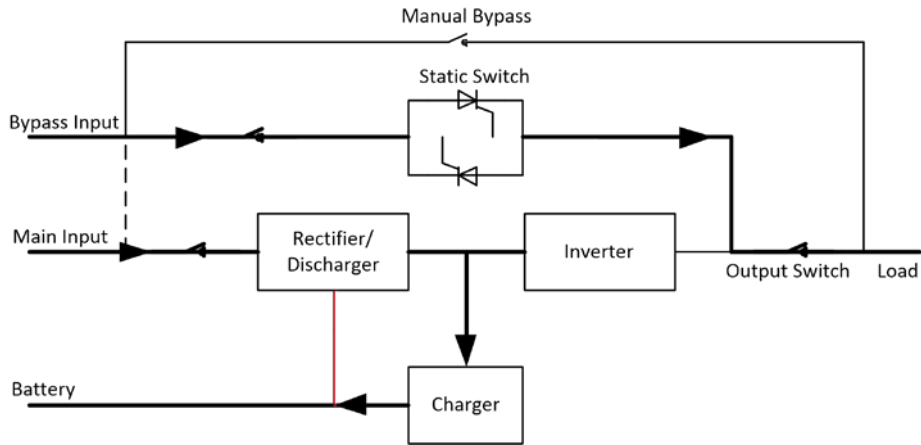

Fig.2-6 ECO Mode operation diagram

**Note**

There is a short interruption time (less than 10ms) when transfer from ECO mode to battery mode, it must be sure that the interruption has no effect on loads.

**2.3.6 Auto-restart Mode**

The battery may become exhausted following an extended AC mains failure. The inverter shuts down when the battery reaches the End of Discharge Voltage (EOD). The UPS may be programmed to “System Auto Start Mode after EOD”. The system starts after a delay time when the AC mains input recovers. The mode and the delay time are programmed by the commissioning engineer.

**2.3.7 Frequency Converter Mode**

By setting the UPS to Frequency Converter mode, the UPS could present a stable output of fixed frequency (50 or 60Hz), and the bypass static switch is not available.

**2.3.8 Self Aging Mode**

If users want to burn in UPS without load, could set the UPS as Self Aging Mode, in this mode, the current flow through rectifier, inverter, and back to input through bypass. It needs only 5% loss to burn in UPS with 100% load.

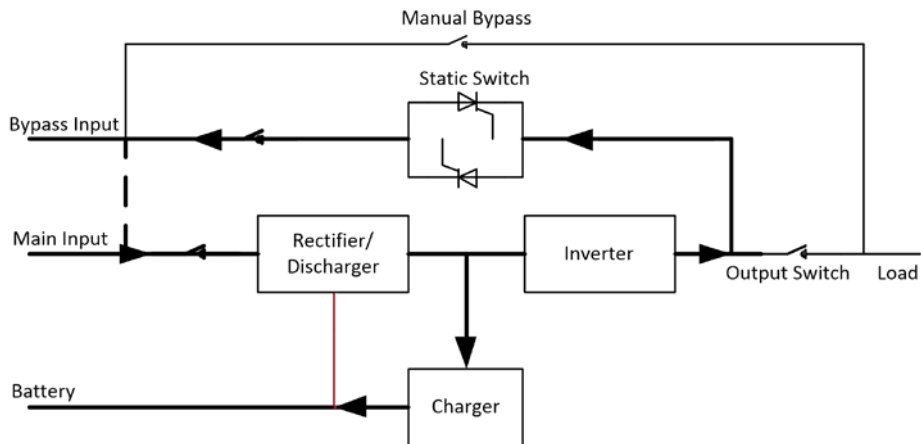

Fig.2-7 self aging operation diagram

## 2.4 UPS Structure

### 2.4.1 UPS Configuration

The UPS configuration is provided in Table 2.1

Table 2.1 UPS Configuration

Item	Components	Quantity	Remark
Long Backup Type(H)	Dual Input	1	Standard
	Parallel Card,	1	Optional
	Dry Contact Card	1	Optional

### 2.4.2 UPS Outlook

The UPS outlook is shown as Fig.2-8 to Fig. 2-10.

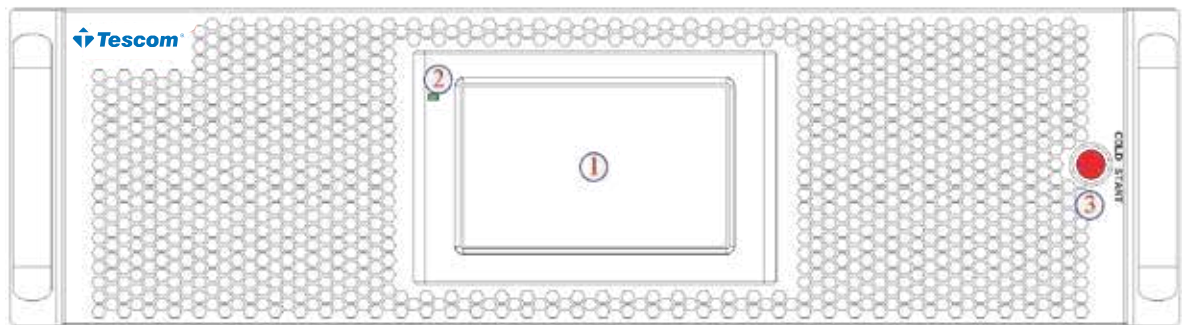

Fig. 2-8 10-30kVA front appearance

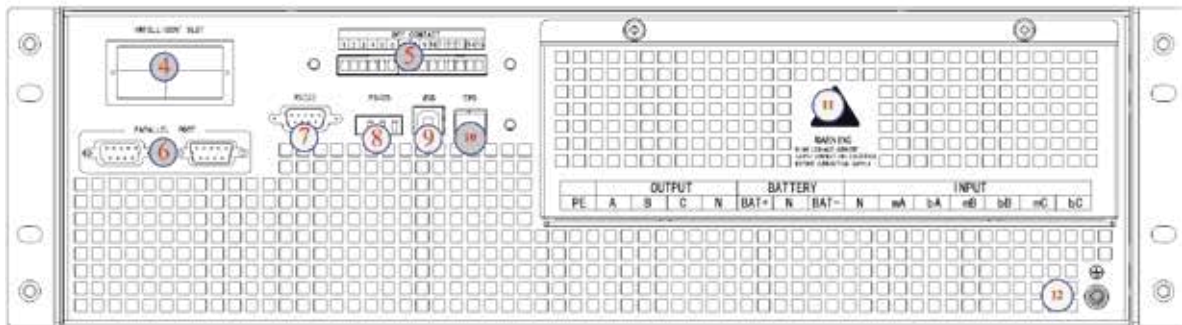

Fig. 2-910-20kVA back appearance

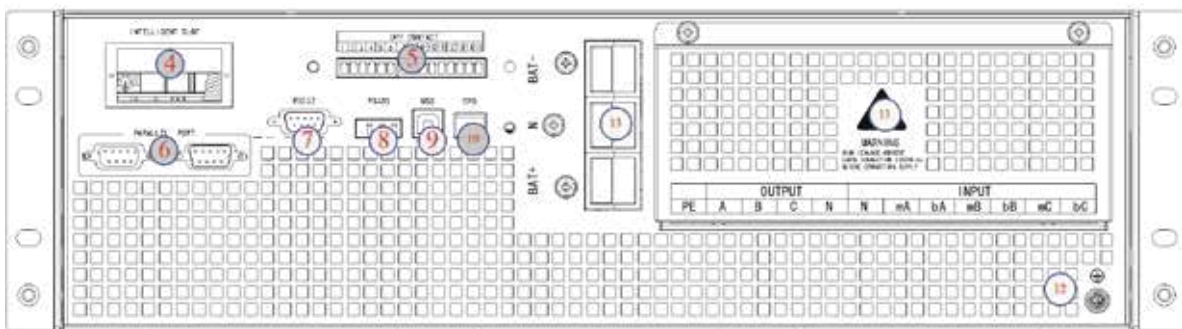

Fig. 2-1030kVA back appearance

---

 **Note**

The Standard product is configured with single input; the dual-input option is available, with an additional breaker for the main input.

Table2.2 UPS Configuration

<b>Item</b>	<b>Description</b>
1	The touch screen LCD
2	LED
3	Cold start button, used to light up the LCD in battery mode
4	Intelligent slot :SNMP
5	Dry contact: option
6	Parallel port: option
7	RS232,used to connect monitoring software
8	RS485, used to connect monitoring software
9	USB: B type, used to connect monitoring software
10	EPO
11	Connection terminals and protective cover
12	GND
13	Battery connectors for 30kVA

---

## 3. Installation Instruction

### 3.1 Location

As each site has its requirements, the installation instructions in this section are to act as a guide for the general procedures and practices that should be observed by the installing engineer.

#### 3.1.1 Installation Environment

1、 The UPS is intended for indoor installation and uses forced convection cooling by internal fans. Please make sure there is enough space for the UPS ventilation and cooling.

2、 Keep the UPS far away from water, heat and inflammable and explosive, corrosive material. Avoid installing the UPS in the environment with direct sunlight, dust, volatile gases, corrosive material and high salinity.

3、 Avoid installing the UPS in the environment with conductive dirt.

4、 The operating environment temperature for battery is 20°C -25°C. Operating above 25°C will reduce the battery life, and operation below 20°C will reduce the battery capacity.

5、 The battery will generate a little amount of hydrogen and oxygen at the end of charging; ensure the fresh air volume of the battery installation environment must meet EN50272-2001 requirements.

6、 If external batteries are to be used, the battery circuit breakers (or fuses) must be mounted as close as possible to the batteries, and the connecting cables should be as short as possible.

#### 3.1.2 Site Selection

Ensure the ground or installation platform can bear the weight of the UPS cabinet, batteries and battery rack.

No vibration and less than 5 degree inclination horizontally.

The equipment should be stored in a room so as to protect it against excessive humidity and heat sources.

The battery needs to be stored in dry and cool place with good ventilation. The most suitable storage temperature is 20 °C to 25°C.

#### 3.1.3 Size and Weight

The size of three dimensions and weight for the UPS cabinet is shown in Table 3.1.



#### Attention

Ensure there is at least 0.8m before the front of the cabinet so as to easily maintain the power module and at least 0.5m behind for ventilation and cooling.

---

Table 3.1 Size and Weight for the cabinet

Configuration	Size(W* H * D)	Weight
10kVA Long Backup Type	440*130*660mm	24kg
15kVA Long Backup Type	440*130*660mm	24kg
20kVA Long Backup Type	440*130*660mm	24kg
30kVA Long Backup Type	440*130*750mm	29kg

### 3.1.4 Installation Tools

	<b>DANGER</b>
	To ensure safety, installation tools for live operation shall be insulated.

Installation tools which may be used in installation process are shown in Table 3-2 and used as needed.

Table 3-2 Installation tools

Tool name	Main function	Tool name	Main function
Forklift	Handling	Nail hammer	Knock, install and remove components
Herringbone ladder	High-place operation	Rubber hammer	Knock and install components
Clip-on ammeter	Detect current	Percussion drill, drill bit	Drill
Multimeter	Check electrical connection and electrical parameters	Insulating tape	Electrical insulation
Cross screwdriver	Fasten screw	Heat-shrinkable tubing	Electrical insulation
Leveling instrument	Leveling	Heat gun	Heat heat-shrinkable tubing
Insulated monkey wrench	Tighten and loosen bolts	Electrician's knife	Wire stripping
Insulated torque wrench	Tighten and loosen bolts	Cable tie	Bundle
Crimping pliers	Cc cold-pressed terminal	Leather working gloves	Protect operator's hands
Hydraulic clamp	Clamp OT terminal	Antistatic gloves	Anti-static
Diagonal pliers	Shear cables	Insulating gloves	Insulation
Wire stripper	Wire stripping	Insulated protective shoes	Protect operator

## 3.2 Unpacking and Inspection

### 3.2.1 Unpacking of the Cabinet

The steps to unpack the cabinet are as follows:

1. Check if any damages to the packing. (If any, contact to the carrier)
2. Unpack the package.
3. Remove the protective foam around the cabinet.
4. Check the UPS.
  - (a) Visually examine if there are any damages to UPS during transportation. If any, contact to the carrier.
  - (b) Check the UPS with the list of the goods. If any items are not included in the list, contact to our company or the local office.



### Attention

Be careful while removing to avoid scratching the equipment.





### Attention

The waste materials of unpacking should be disposed to meet the demand for environmental protection.

---

## 3.3 Main cabinet installation

Two installation modes are available: tower installation and rack installation, depending on available space and user considerations. You can select an appropriate installation mode according to the actual conditions.

### 3.3.1 Tower Installation

Various installation configurations are available: single UPS, single UPS with single or multiple battery cabinets. Their installation methods are all the same.

The installation procedures are as follows:

Step 1: Take out the support bases from the accessories. Their appearances are shown in Fig.3-1.

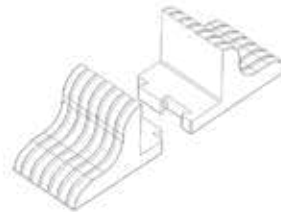

Fig.3-1 Support bases

Step 2: If optional external battery cabinets are connected to the UPS to provide additional battery run time, assemble the spacers and the support bases, as shown in Fig.3-2.

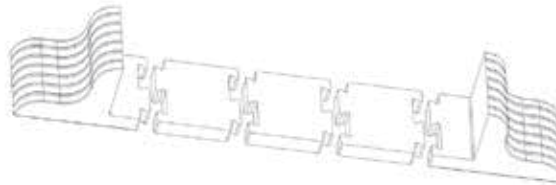

Fig.3-2 Installing support bases with spacers

Step 3: Place the UPS (and battery cabinet) on the support bases. Each UPS needs two pairs of support bases to install, as shown in Fig.3-3.

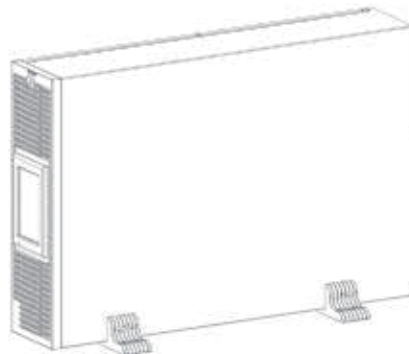

Fig.3-3 Tower installation

---

### 3.3.2 Rack Installation

1. Various installation configurations are available: single UPS, single UPS with single or multiple-battery. Their installation methods are all the same.
2. Because battery cabinets are too heavy, they must be installed first, and two or more installation personnel are required to install them at the same time. Please install them from bottom to top.

Rack installation: fix the UPS and battery cabinet onto the rack through brackets.

Installation method:

1. Fix the brackets onto the UPS with the screws, as shown in Fig.3-4.

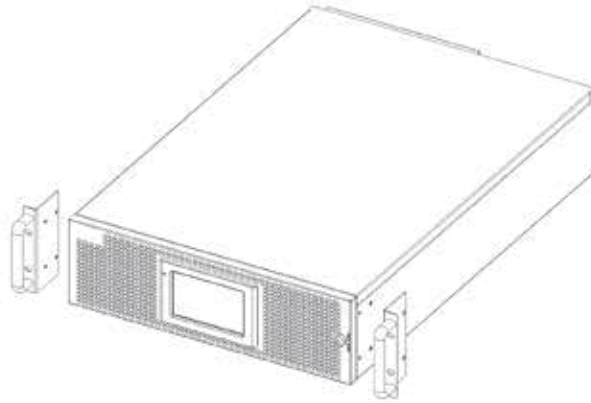

Fig.3-4 Installing brackets

2. Place the UPS and battery cabinet onto the guide rail in the rack, push it completely into the rack along the guide rail (it is prohibited to move the UPS through the brackets). Fix the units to the service rack, as shown in Fig.3-5.

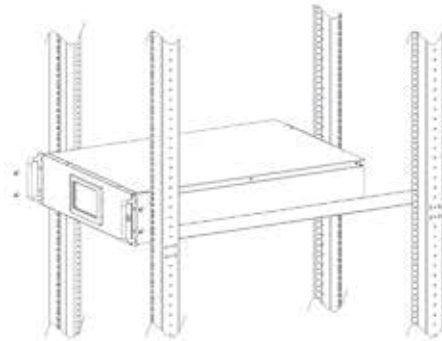

Fig.3-5 Installing UPS

### 3.4 Battery

Three terminals (positive, neutral, negative) are drawn from the battery unit and connected to UPS system. The neutral line is drawn from the middle of the batteries in series (See Fig.3-6).

Select total number of batteries from 30 to 44 (even number), and the number of positive and negative battery strings must be consistent. 10kVA could select the total number 20pcs.

30kVA connect to the battery with Anderson connectors (See Fig.3-2).

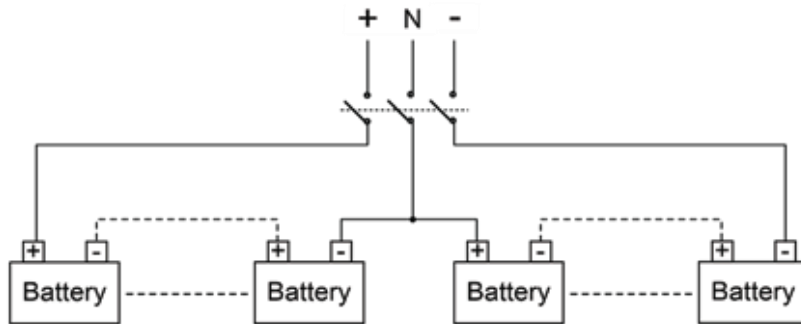

Fig 3-6 Battery string wiring diagram



**Danger**

The battery terminal voltage is of more than 200Vdc, please follow the safety instructions to avoid electric shock hazard.

Positive and negative battery strings must be equipped with a 3-channel battery breaker with limited current protection.

Ensure the positive, negative, neutral electrode is correctly connected from the battery unit terminals to the breaker and from the breaker to the UPS system.

**3.5 Cable Entry**

Cable entry is made possible through a blanking plate fitted at the back of the equipment. The cable entry is shown in Fig.3-7.

30kVA connect to the battery with Anderson connectors (See Fig.3-8).

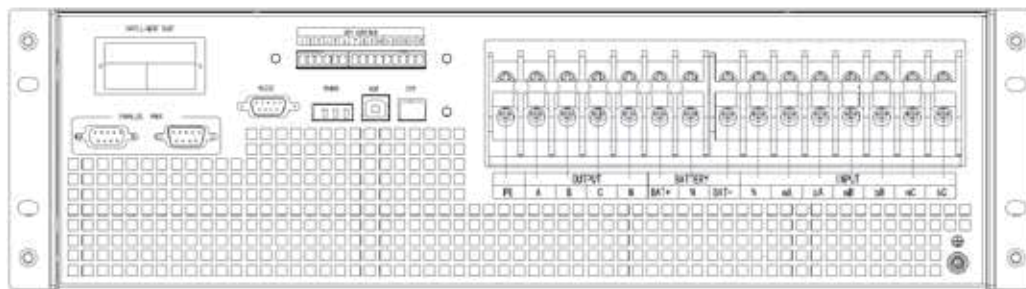

Fig.3-7 10-20kVACable entry

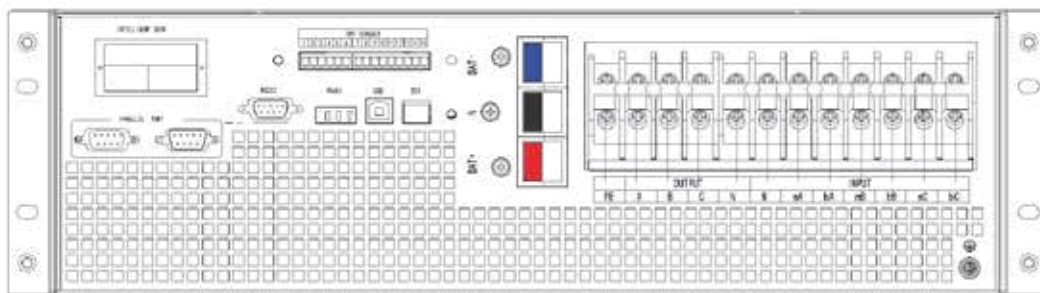

Fig.3-8 30kVACable entry

## 3.6 Power Cables

### 3.6.1 Specifications

The UPS power cables are recommended in Table 3.3.

Table 3.3 Recommended cables for power cables

Contents		10kVA	15kVA	20kVA	30kVA	
Main Input	Main Input Current(A)	20A	29A	39A	58A	
	Cable Section (mm <sup>2</sup> )	A	6	6	10	16
		B	6	6	10	16
		C	6	6	10	16
		N	6	6	10	16
Main Output	Main Output Current(A)	15A	23A	30A	45A	
	Cable Section (mm <sup>2</sup> )	A	6	6	10	16
		B	6	6	10	16
		C	6	6	10	16
		N	6	6	10	16
Bypass Input (Optional)	Bypass Input Current(A)	15A	23A	30A	45A	
	Cable Section (mm <sup>2</sup> )	A	6	6	10	16
		B	6	6	10	16
		C	6	6	10	16
		N	6	6	10	16
Battery Input	Battery Input current(A)	53A	50A	66A	106A	
	Cable Section (mm <sup>2</sup> )	+	10	10	16	25
		-	10	10	16	25
		N	10	10	16	25
PE	Cable Section (mm <sup>2</sup> )	PE	6	6	10	16

#### Note

The recommended cable section for power cables are only for situations described below:

- Ambient temperature: 30°C.
- AC loss less than 3%, DC loss less than 1%, The length of the AC power cables are no longer than 50 m and the length of the DC power cables are no longer than 30 m.
- Currents listed in the table are based on the 208V system (Line-to-line voltage).
- The size of neutral lines should be 1.5~1.7 times the value listed above when the predominant load is non-linear.

### 3.6.2 Specifications for Power Cables Terminal

Specifications for power cables connector are listed as Table 3.4.

Table 3.4 Requirements for power module terminal

Port	Connection	Bolt	Bolt Aperture	Torque Moment
Mains input	Cables crimped OT terminal	M5	5.8mm	3Nm
		M6	7mm	4.9Nm
Bypass Input	Cables crimped OT terminal	M5	5.8mm	3Nm
		M6	7mm	4.9Nm
Battery Input	Cables crimped OT terminal	M5	5.8mm	3Nm
		M6	7mm	4.9Nm
Output	Cables crimped OT terminal	M5	5.8mm	3Nm
		M6	7mm	4.9Nm
PE	Cables crimped OT terminal	M5	5.8mm	3Nm
		M6	7mm	4.9Nm

### 3.6.3 Circuit Breaker

The circuit breakers (CB) for the system are recommended in Table 3.5.

Table 3.5 Recommended CB

Installed position	10kVA	15kVA	20kVA	30kVA
Battery CB	63A,250Vdc	63A,250Vdc	63A,250Vdc	100A,250Vdc



#### Attention

The CB with RCD (Residual Current Device) is not suggested for the system.

### 3.6.4 Connecting Power Cables

The steps of connecting power cables are as follows:

1. Verify that all the switches of the UPS are completely open and the UPS internal maintenance bypass switch is open. Attach necessary warning signs to these switches to prevent unauthorized operation.
2. Open the back door of the cabinet, remove the cover. The input and output terminal, battery terminal and protective earth terminal are shown in Fig.3-9 & Fig. 3-10.

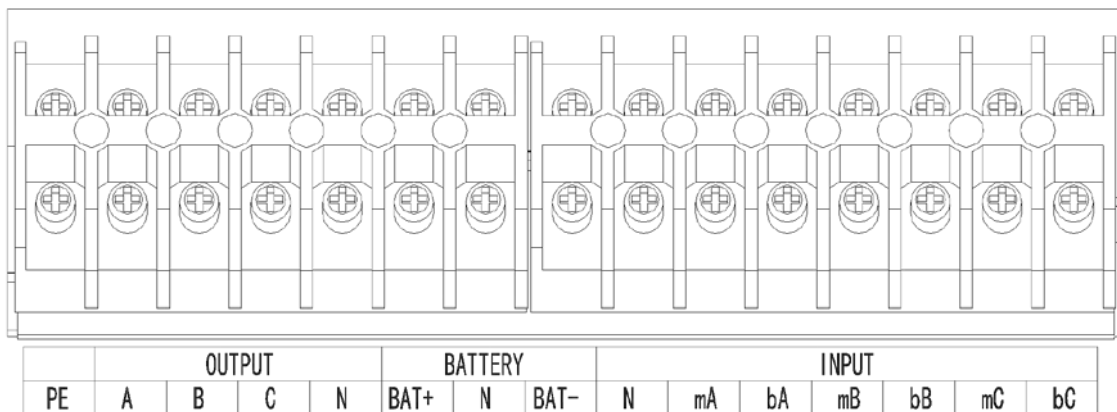

Fig.3-9 connections terminals for 10-20kVA

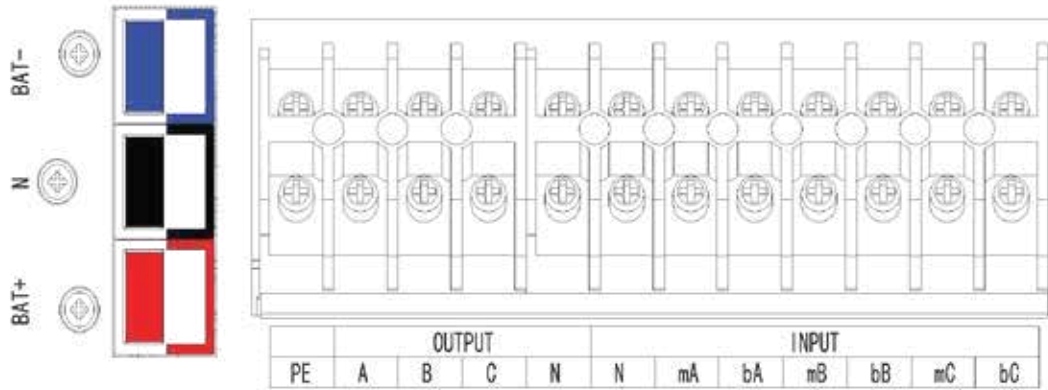

Fig.3-10 connections terminals for 30kVA

3. Connect the protective earth wire to protective earth terminal (PE).
4. Connect the AC input supply cables to the Input terminal and AC output supply cables to the Output terminal.
5. Connect the Battery cables to the Battery terminal.
6. Check to make sure there is no mistake and re-install all the protective covers.

**Note: mA, mB, mC standard for Main input phase A,B and C; bA, bB, bC standard for Bypass Input phase A,B and C.**



#### Attention

The operations described in this section must be performed by authorized electricians or qualified technical personnel. If you have any difficulties, contact the manufacturer or agency.



#### Warning

- Tighten the connections terminals to enough torque moment, refer to Table 3.3, and please ensure correct phaserotation.
- The grounding cable and neutral cable must be connected in accordance with local and national codes.
- When the cable holes does not goes through by cables, it should be filled by the hole stopper

### 3.7 Control and Communication Cables

The rear panel of the UPS provides dry contact interface and communication interface (RS232, RS485,SNMP ,Intelligent card interface and USB port), as it is shown in Fig.3-11.

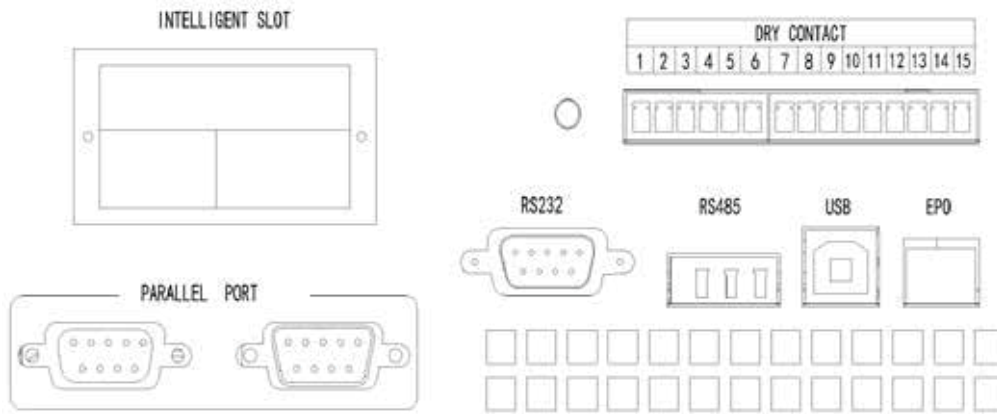

Fig.3-11 Dry contact & communication interface

### 3.7.1 Dry Contact Interface

Dry contact interface includes port J1-J18 and the functions of the dry contact are shown in Table 3.6.

Table 3.6 Functions of the port

Port	Name	Function
1	IN_DRY1_NC	Input dry contact-1,1-2, (Normally closed)function issettable , Default: none
2	Vcc_GJ	VCC
3	IN_DRY2_NO	Input dry contact-2,3-4, (Normally open) function issettable , Default: None
4	GND	Ground for Vcc
5	IN_DRY3_NO	Input dry contact-3,5-6, (Normally open) function issettable , Default: None
6	GND	Ground for Vcc
7	OUT_DRY1_NO	Output dry contact-1, 7-9(Normally open) function issettable. Default: None If used for BCB_DRV,6-7, provide +15V voltage, 20mA drive signal
8	OUT_DRY1_NC	Output dry contact-1, 8-9(Normally closed) function issettable. Default: None
9	OUT_DRY1_GND	Common terminal for 7 and 8
10	OUT_DRY2_NO	Output dry contact-2, 10-12(Normally open), function issettable. Default: None
11	OUT_DRY2_NC	Output dry contact-2, 11-12(Normally closed), function issettable. Default: None
12	OUT_DRY2_GND	Common terminal for 10and 11,
13	OUT_DRY3_NO	Output dry contact-3, 13-15(Normally open), function issettable. Default: None
14	OUT_DRY3_NC	Output dry contact-3, 14-15 (Normally closed), function issettable. Default: None
15	OUT_DRY3_GND	Common terminal for 13 and 14

---

 **Note**

The settable functions for each port can be set by the monitor software or touch screen.

Specified temperature sensor is required for temperature detection (R25=5Kohm, B25/50=3275), please confirm with the manufacturer, or contact the local maintenance engineers when placing an order.

The output dry contact interface: An auxiliary dry contact signal will be activated via the isolation of a relay.

### **3.7.2 Communication Interface**

RS232 、 RS485 and USB port : Provide serial data which can be used for commissioning and maintenance by authorized engineers or can be used for networking or integrated monitoring system in the service room.

Optional smart cards: SNMP card, GPRS card and Wi-Fi card etc.

The smart cards are installed in the optional card slot of UPS, which support hot-plug and feature convenient installation. Proceed as follows:

Step 1: first remove the cover plate from the intelligent slot;

Step 2: insert the required smart card into the slot;

Step 3: lock the smart card with previously removed screws.

**SNMP card** is compatible with today's popular Internet software and firmware and network operating system and provide direct the direct Internet access function for UPS to provide instant UPS data and power supply information, and achieve communication and management by communication network management systems, the network communication of UPSs and convenient centralized monitoring and management of each UPS. Please refer to supporting operation instruction for details.

**4G card** allows UPS to connect the Internet through 4G data (local SIM card is required), and the server for data communication, and UPS may be monitored online through computer or mobile phone. Please refer to supporting operation instruction for details.

**GPRS card** allows UPS to connect the Internet through GPRS data (local SIM card is required), and the server for data communication, and UPS may be monitored online through computer or mobile phone. Please refer to supporting operation instruction for details.

**Wi-Fi card** allows UPS to connect the Internet through Wi-Fi and the server for data communication, and UPS may be monitored online through computer or mobile phone. Please refer to supporting operation instruction for details.



---

## 4.LCD Panel

### 4.1 Introduction

This chapter introduces the functions and operator instructions of the operator control and display panel in detail, and provides LCD display information, including LCD display types, detailed menu information, prompt window information and UPS alarm information.

### 4.2 LCDpanel for Cabinet

The structure of operator control and display panel for cabinet is shown in Fig.4-1. The operation control panel of UPS is located on the front panel of the case. By operating the LCD, the ups can be operated, controlled, and checked for all its parameters, operating status, and alarm information.



Fig.4-1 Control and display panel

The LCDpanel for cabinet is divided into two functional areas: LED indicator, LCD touch screen.

#### 4.2.1 LEDIndicator

There are 2 LEDs on the panel to indicate the operating status and fault. (See Fig.4-1). The description of indicators is shown in Table 4.1

Table 4.1 Status description of indicators

Indicators	State	Description
red	Steady red	UPS fault
	Flashing red	UPS alarming
green	Steady green	Power supply mode (mains mode, bypass mode, ECO mode, etc.)
No	None	Standby status or no starting

#### 4.2.2 Alarm type

There are two different types of audible alarm during UPS operation, as shown in Table 4.2.

Table 4.2 Description of audible alarm

Alarm	Description
Intermittent alarm	when system has general alarm (for example: AC fault),
Continuous alarm	When system has serious faults (for example: hardware fault)



### Attention

When bypass frequency is over track, there is interruption time (less than 10ms) for transferring from bypass to inverter.

### 4.2.3 LCD Menu structure

The menu structure of the monitoring display interface is shown in Fig. 4-2.

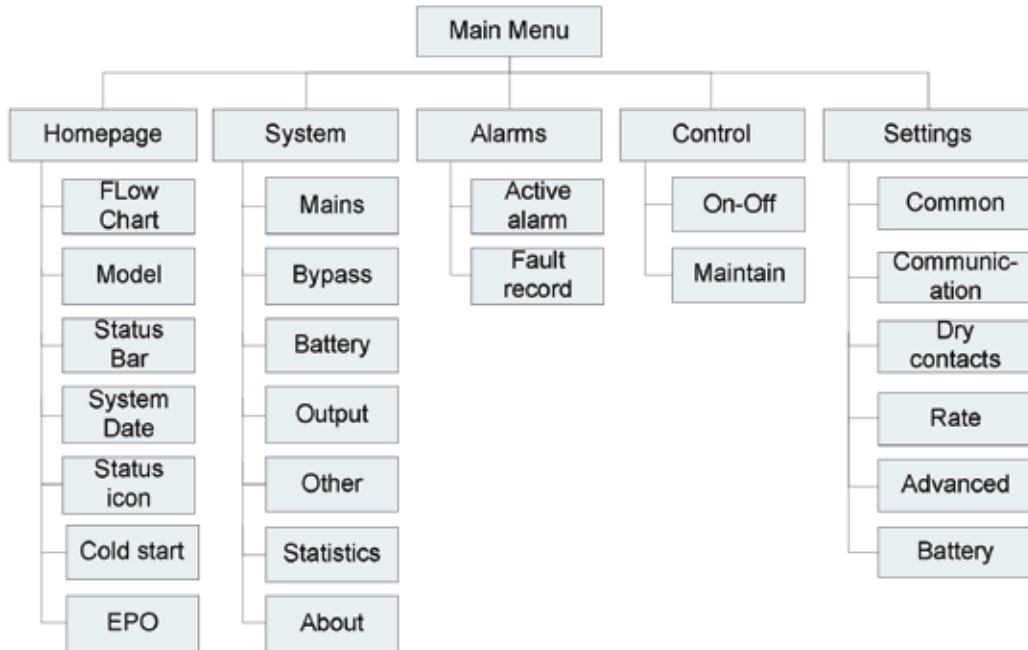

Fig. 4-2 Menu

### 4.2.4 Home page

After the monitoring system starts self-test, the system enters the home page, following the welcome window. The home page is divided into three parts, including main menu, energy flow diagram, status bar. The home page is shown in Fig. 4-3:

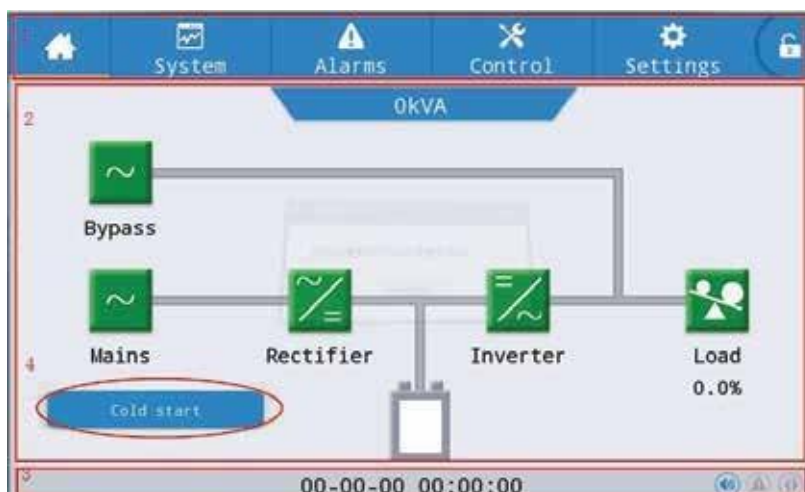

Fig. 4-3 Home page

Table 4-3 Function description of interface area

No.	Area	Function description
1	Main menu	Level 1 menu, including home page, system, alarm, control, settings, password login. The control and the settings are displayed in gray before login by password.
2	Energy flow diagram	Display the energy flow state of the cabinet. Click the corresponding work interface to view the status information.
3	Status bar	Display operation status, system time, buzzer status, alarm status, HMI and monitoring communication status, USB status of the cabinet.
4	Cold start	Start the UPS in battery mode. The icon will be hidden after two minutes.
5	EPO	Enter or escape the EPO mode

Table 4-4 Description of icons in status bar



Icon	Function description
	Buzzer status, which becomes lit to indicate the buzzer enabled, and off to indicate the buzzer disabled
	Alarm status, which becomes lit to indicate an alarm, and off to indicate no alarm
	Password login/logout key. After clicking, enter user password or advanced password by the keyboard. The screen will be locked automatically.

Table 4-5 Description of password permissions

Password permissions	Default	Function description
User password	123456	Unlock On and OFF control right and the right of common settings and communication settings. It can be changed in "settings - common settings - user password".
Advanced password	Not opened	Unlock all control and setting rights. It can be used by qualified electricians only.

#### 4.2.5 System

In the "System" information interface, the "Mains", "Bypass ", "Battery ", "Output", "Other", "Statistics" and "About " information of the system can be inquired in the secondary menu at the left side.

##### Mains

The menu interface of the mains input is shown in Fig. 4-4, and displays information on three phases ABC from left to right. The interface description is shown in Table 4-6.

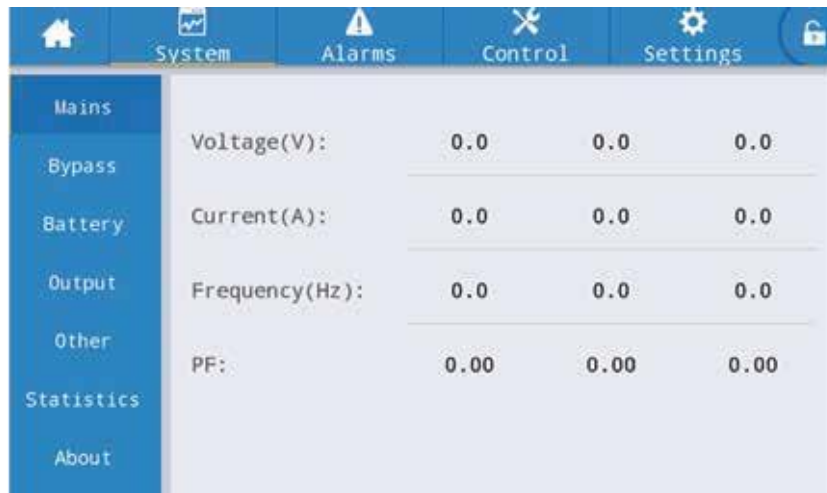

Fig. 4-4 Input interface

Table 4-6 Description of input interface

Display item	Description
Voltage(V)	Mains input phase voltage
Current(A)	Mains input phase current
Frequency(Hz)	Mains input frequency
PF	Mains input Power factor

### Bypass

The menu interface of the bypass input is shown in Fig. 4-5, and the interface description is shown in Table 4-7.

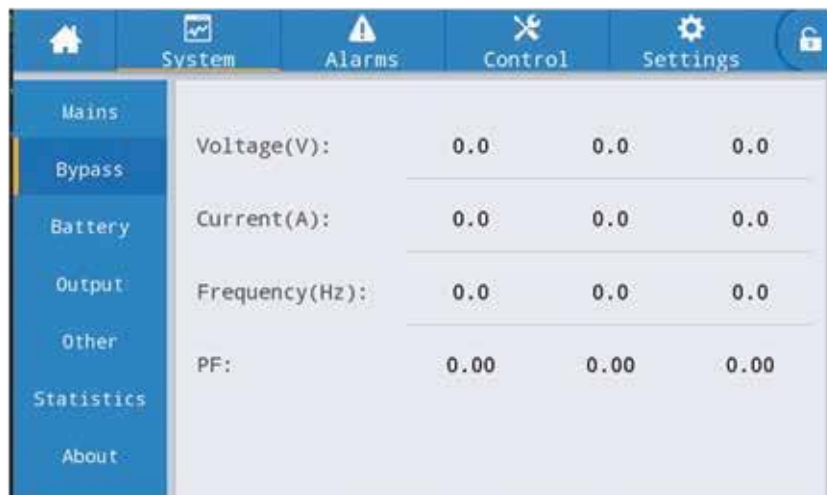

Fig. 4-5 Bypass interface

Table 4-7 Description of bypass interface

Display item	Description
Voltage(V)	Bypass input phase voltage
Current(A)	Bypass input phase current
Frequency(Hz)	Bypass input frequency
PF	Bypass input Power factor

## Battery

The interface menu of battery input is shown in Fig. 4-6, and the interface description is shown in Table 4-8.



Fig. 4-6 Battery interface

Table 4-8 Description of battery interface

Display item	Description
Battery voltage(V)	Battery voltage
Battery Current(A)	Battery current
Battery status	Current battery status: idle, discharge, boost charge, floating charge, None
Temperature(°C)	Current operating temperature of battery (optional battery temperature sensor, display "NA" if not connected)
Backup time(min)	Estimated discharge time of the battery at the current load
Remaining cap.(%)	Current remaining capacity of battery

## Output

The interface of output menu is shown in Fig. 4-7, and the interface description is shown in Table 4-9.

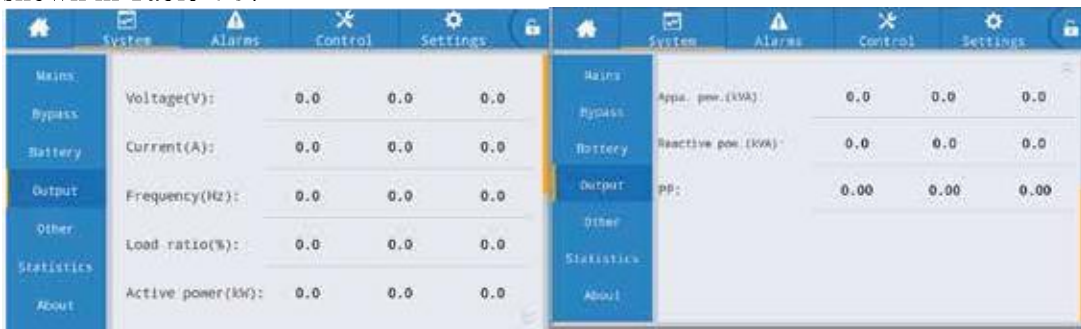

Fig. 4-7 Output interface

Table 4-9 Description of output interface

Display item	Description
Voltage(V)	AC output phase voltage.
Current(A)	AC output phase current.
Frequency(Hz)	AC output frequency.
Load ratio(%)	Load rate of each phase of the machine, i.e. the ratio of actual power to rated power.
Active power(kW)	Output active power of each phase of the UPS unit
Appa. pow.(kVA)	Output apparent power of each phase of the UPS unit
Reactive power(kVA)	Output reactive power of each phase of the UPS unit
PF	Output power factor of each phase of the UPS unit

## Other

The interface of other menu is shown in Fig. 4-8, and the interface description is shown in Table 4-10.

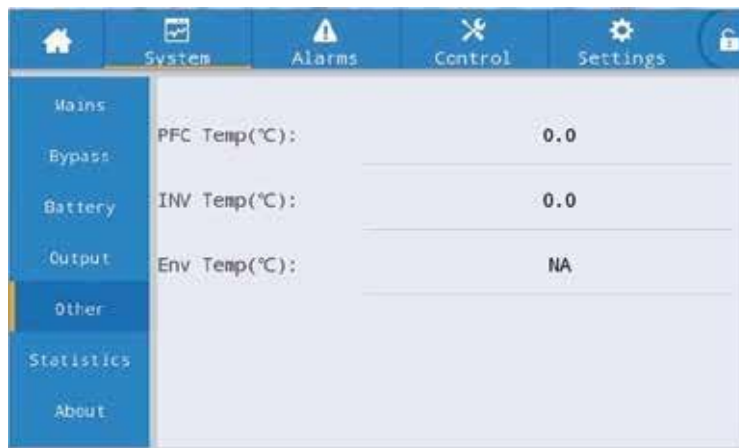

Fig. 4-8 Other interface

Table 4-10 Description of other interface

Display item	Description
PFC temperature	Rectifier temperature
INV temperature	Inverter temperature
Environmental temperature	Environmental temperature(optional battery temperature sensor, display "NA" if not connected)

## Statistics

The interface of statistics menu is shown in Fig. 4-9, and the interface description is shown in Table 4-11.

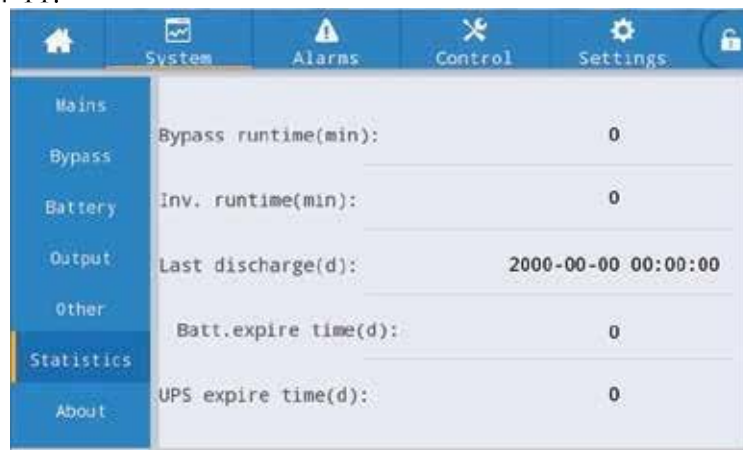

Fig. 4-9 Statistics interface

Table 4-11 Description of statistics interface

Display item	Description
Bypass runtime(min)	Accumulative operation time of UPS in bypass output status
Inv. Runtime(min)	Accumulative operation time of UPS in inverter output status
Last discharge	Date of previous discharge status of UPS
Batt.expire time	When the system time exceeds the warranty period, the status bar will prompt the warranty information of battery.
UPS expire time	When the system time exceeds the warranty period, the status bar will prompt the warranty information of main machine.

## About

The interface of “About” menu is shown in Fig. 4-10, and the interface description is shown in Table 4-12.



Fig. 4-10 About interface

Table 4-12 Description of Interface

Display item	Description
S/N	Production serial number of this machine.
TEL	Contact information of after-sales service providers.
Manufacturer	Manufacturer of this machine.
Website	Website of manufacturer of this unit.
HMI version	Program version of HMI display system.
PFC1 version	Program version of power rectifier system
Inv.1 version	Program version of power inverter system
Protocol version	Program version of LCD display system

### 4.2.6 Alarm information

In the "Alarms" information interface, you can view "Active alarm" and "Fault record" from the secondary menu in the lower left corner. Click to select the type of alarm you want to view. The interface of alarm menu is shown in Fig. 4-11



Fig. 4-11 Alarm menu interface

### Active alarm

The active alarm interface displays the relevant information of the current warning of UPS system, The interface description is shown in Table 4-13.

Table 4-13 Description of active alarm interface

Display item	Description
No.	Alarm number
Location	Display the cabinet number and module number of the current alarm source.
ID	Alarm code for program analysis.
Information	Current alarm name
Time	The current alarm is the current alarm information without time display.

### History records

The "history record" is divided into "Fault record", "Status record" and "Operating record". Take "Fault record" as an example, The interface description is shown in Table 4-14.

Table 4-14 Description of history record interface

Display item	Description
No.	Record number, which is listed in reverse order, that is to say the latest record is in the front.
Location	Displays the module number of the current record source.
ID	List code of fault, status or operation information for program analysis
Information	Current record name and record state (occurrence, disappearance).
Time	Record the time of occurrence or disappearance.

### 4.2.7 Control

In the "Control" information interface, you can select relevant operation from the left secondary menu, which contains "On-Off" and "Maintain".

#### On-Off

The interface of the On-Off menu is shown in Fig. 4-12, and the interface description is shown in Table 4-15.

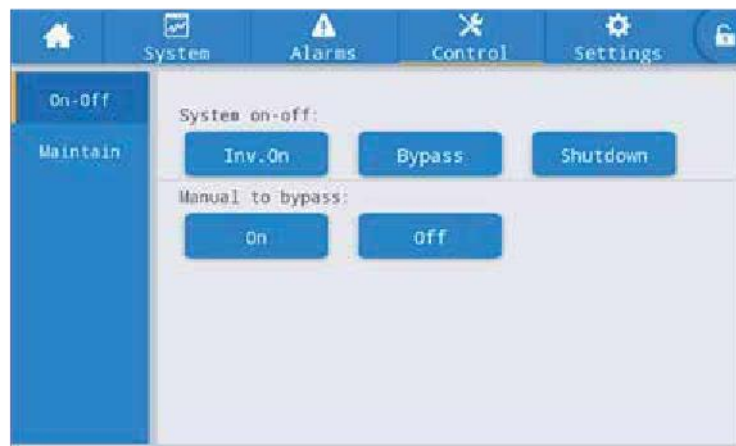

Fig. 4-12 On-Off interface

Table 4-15 Description of On-Off interface

Control item	Description
System on-off	Including "Inv.On", "Shut to bypass" and "Shutdown". It is gray when clicking is invalid.
Manual to bypass	Including "On" and "Off". It is gray when clicking is invalid. If the bypass is abnormal, switching to bypass fails.



## Maintenance

The interface of maintenance menu is shown in Fig. 4-13, and the interface description is shown in Table 4-16.



Fig. 4-13 Maintenance interface

Table 4-16 Description of maintenance interface

Control item	Description
Mute	Mute the buzzer
Clear history	Clear history
Faults Clear	Clear the fault
Bat Test1	UPS transfer to battery discharge mode to test if the battery is normal. Bypass must be in normal condition, the battery capacity should be above 25%.
Bat Test2	This test will lead to the battery being partly discharged to activate battery until battery voltage is low. Bypass must be in normal condition, the battery capacity should be above 25%.
Stop Bat Test	Manually Stop the test including maintenance test, capacity test
Resume Factory Setting	Resume Factory Setting
LCD Rotate	LCD display direction switch

## 4.2.8 Settings

### Common settings

The interface of common settings menu is shown in Fig. 4-14, and the interface description is shown in Table 4-17.



Fig. 4-14 Common setting interface

Table 4-17 Description of common setting interface

Setting item	Default	Options	Description
Language	English	English	Display in English.
YYYY-MM-DD	2016-01-01	2000-01-01~2099-12-31	Set the current date.
Time	00:00:00	00:00:00~23:59:59	Set the current time.
Date format	Y-M-D	Y-M-D, M-D-Y, D-M-Y	Support 3 formats: Y-M-D, M-D-Y, D-M-Y.
Brightness	100%	0% ~ 100%	Adjust backlight brightness by moving the slider.
Auto-lock	5 min	0~30min	Set screen time out. 0 is set to keep the screen on.

### Communication settings

The interface of the communication setting menu is shown in Fig. 4-15, and the interface description is shown in Table 4-18.

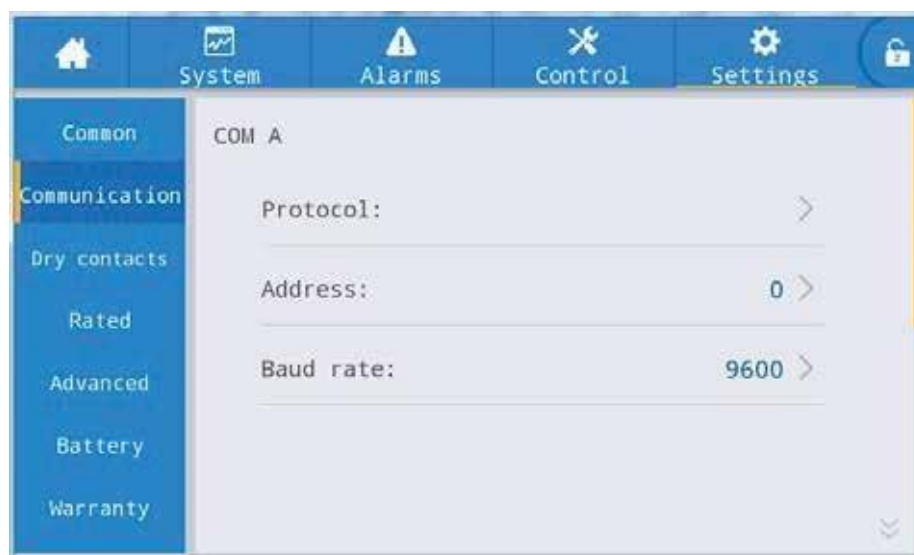

Fig. 4-15 Communication settings interface

Table 4-18 Description of communication settings interface

Setting item	Default	Options	Description
Protocol	MODBUS RTU	MODBUSRTU, EA	Settings such as Protocol, Address and Parity are set for serial ports, including USB interface, RS232 interface and RS485 interface. Users can make the corresponding settings according to the setting requirements of the monitoring software used, but ensure that the setting value in the monitoring software must be consistent with the value in the UPS communication settings.
Address	0	0~ 247	
Baud rate	9600	2400-19200	

### Dry contact settings

The interface of dry contact setting menu is shown in Fig. 4-16, and the interface description is shown in Table 4-19.

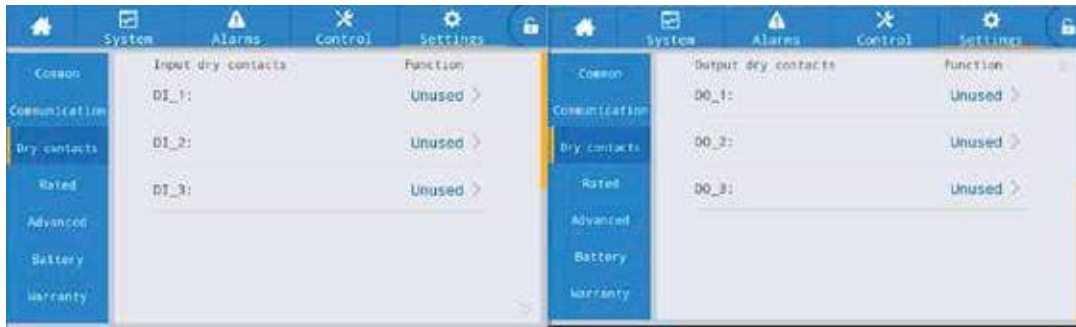

Fig. 4-16 Dry contact setting interface

Table 4-19 Description of dry contact setting interface

INTERFACE	Name	Function
<b>Input Dry Contact</b> DI_1 ~ DI_3	D.G.mode	Connection status of generator, Select IN_DRY1_NC
	EPO	EPO , Select IN_DRY1_NC
	BCB online	BCB on-lineinput (normally open), Select IN_DRY2/3_NO
	BCB status	BCB contact status, connect with the normally open signal of BCB. Select IN_DRY2/3_NO.
	INV	Transfer from the bypass to inverter
	Bypass	Transfer from the inverter to bypass
	Fault clear	Fault clear
	Batt over charge	The battery is over charging, the ups will shutdown the charger
	Low batt.volt.	The battery voltage is low, the ups will get ready to shutdown or recharge
<b>Output Dry Contact</b> DO_1~ DO_3	Grid Fault	Grid Fault warning
	Low.Bat.vol	The battery voltage is low
	Load on bypass	The UPS is in bypass mode
	Load on INV	The UPS is in INV mode
	Battery Mode	The UPS is in battery mode
	General Alarm	General Alarm
	Output over load	Output over load
	BCB drive	BCB contact drive, need +15V voltage , 20mA drive signal

### Rate parameters

The interface of the rate parameters menu is shown in Fig. 4-17, and the interface description is shown in Table 4-20.

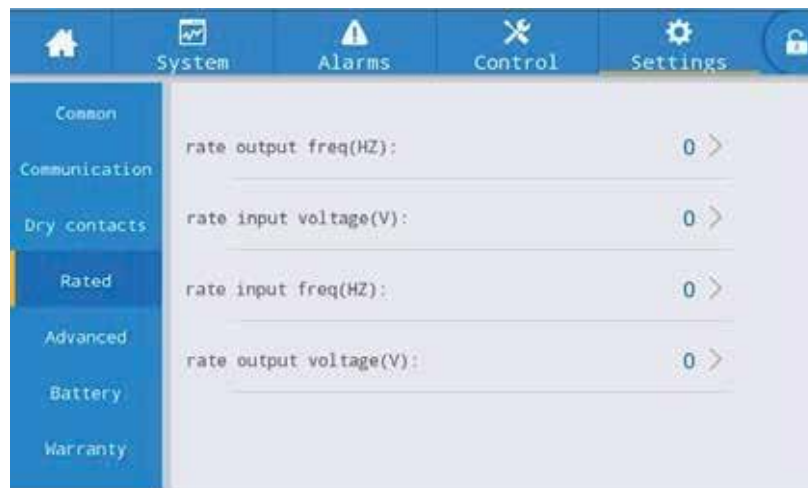

Fig. 4-17 Bypass parameters interface

Table 4-20 Description of bypass parameters interface

Setting item	Default	Options	Description
Rate output freq	50	50/60	Rate output frequency
Rate output voltage	220	100/110/120/127/200/208/220/230/240	Rate output voltage
Rate input freq	50	50/60	Rateinput frequency
Rate input voltage	220	100/110/120/127/200/208/220/230/240	Rate input voltage

### Advanced parameters

The interface of advanced parameters menu is shown in Fig. 4-18, and the interface description is shown in Table 4-21.



Fig. 4-18 Advanced parameters interface

Table 4-21 Description of advanced parameters interface

Setting item	Default	Options	Description
Working mode	Normal	Normal/ECO/Self-age/ Parallel mode	Select the corresponding working mode according to user needs. It is normal working mode in general.
Parallel Number	1	1 ~ 4	Set according to the actual frame numbers of the UPS system installed by the user.
Dev ID	1	1 ~ 10	Set device parallel ID
Output voltage adjust	0	-5.0 ~ 5.0	Fine tune the output voltage according to the customer's field power distribution.
Freq track limit	± 3Hz	± 0.5Hz ~ ± 5Hz	Settable, ± 0.5Hz ~ ± 5Hz, default ± 3Hz
Self-age currpercent(%)	80	30 ~ 100	It is percentage of output current in rated output current in self-aging mode.
Transformer coil turns ratio	1	settable	Set the output transformer coil turns ratio.
Byp volt up limit	+15%	+10%, +15%, +20%, +25%	Upper limit: +10%, +15%, +20%, +25%
Byp volt down limit	-20%	-10%, -15%, -20%, -30%, -40%	Lower limit: -10%, -15%, -20%, -30%, -40%
bypass frq range	±5.0	±1.0/±2.0/±3.0/±4.0/±5.0/±6.0	Note that the bypass frequency range cannot be less than the ECO frequency range.

Setting item	Default	Options	Description
Frequency slew rate(Hz/S)	1	0.5-5.0	Frequency slew rate
Output with motor	Off	On/close	Output with motor or no

### Battery parameters

The interface of battery parameters menu is shown in Fig. 4-19, and the interface description is shown in Table 4-22.



Fig. 4-19 Battery parameters interface

Table 4-22 Description of battery parameters interface

Setting item	Default	Options	Description
Batt.Type	VRLA batt.	Lithium/VRLA	Battery type: VRLA battery and Lithium battery, The supported lithium battery type is 3.2 V lithium iron phosphate battery.
Battery number	40	settable	Set according to the total number of battery cells connected to the UPS system, each conventional lead-acid battery has 6 battery cells, for example, 32 batteries × 6=192 battery cells.
Battery capacity (Ah)	25	settable	Single battery capacity connected to the UPS system.
Charge curr.limit(A)	1	10	Set according to the needs, 20%* UPS capacity limited.
Boost time limit	2	1-48	Set according to the needs.
Cell float voltage	2.25	2.10 ~ 2.35	Charging voltage of single cells under floating charge condition.

Setting item	Default	Options	Description
Cell boost voltage	2.25	2.20~2.45	Charging voltage of single cells under boost charge condition.
Cell EOD voltage for 0.6C	1.65	1.6~1.85	Set according to the needs.
Cell EOD voltage for 0.15C	1.75	1.65~1.9	Set according to the needs.
Boost cycle	1440	1~3000h	Set according to the needs.
Batt auto mainten cycle	2880	720~30000h	This test will lead to the battery being partly discharged to activate battery until battery voltage is low. Bypass must be in normal condition, the battery capacity should be above 25%.
Batt volt low coefficient	1.1	1.05~1.25	Set according to the needs.
Batt mainten cycle	3000	0-3000d	Set according to the actual battery replacement time for the users.

### Warranty parameters

The interface of warranty parameters menu is shown in Fig. 4-20, and the interface description is shown in Table 4-23.

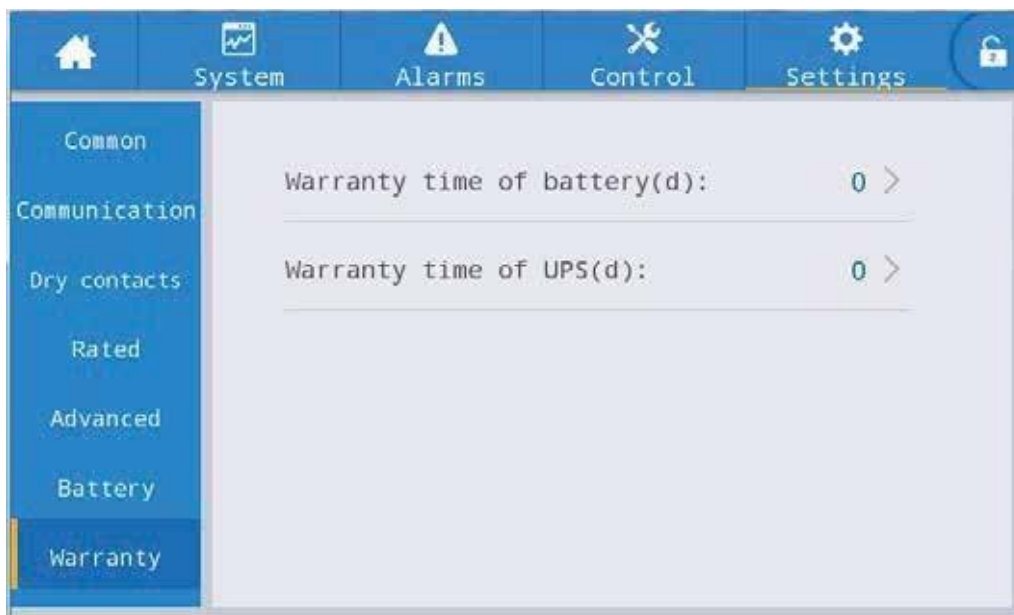

Fig. 4-20 warranty parameters interface

Table 4-23 Description of warranty parameters interface

Setting item	Default	Options	Description
Warranty time of battery (d)	395	settable	Battery overprotection time
Warranty time of UPS(d)	1125	settable	UPS overprotection time

### 4.3 Event List

The following Table4-24 gives events of UPS History Log

Table 4-24 List of History Log

String Sequence	LCD Display	Explanation
230	Battery voltage low (DOD)	Battery voltage is low
231	Battery end of discharge (EOD)	Battery End Of Discharge
232	Bypass fail	Bypass Fail
233	Fan fail	Fan fail
245	UPS maintenance breaker close	Maintenance CB is Closed
336	System board and inverter module CAN communication abnormal	System board and inverter module CAN communication abnormal
337	Same address of multiple inverter	address of multiple inverter is same
352	CAN communication abnormal between system board	CAN communication abnormal between system board
366	Frequency beyond tracing range	Bypass Frequency Over Track Range
368	Bypass phase over voltage	Bypass voltage abnormal
369	Bypass phase under voltage	Bypass voltage abnormal
370	Bypass over frequency	Bypass frequency abnormal
371	Bypass under frequency	Bypass frequency abnormal
372	Bypass phase sequence error	Bypass voltage Sequence is reverse
373	Bypass phase loss	Utility (Grid) Abnormal
374	Bypass phase volt imbalance	Bypass voltage is not balance
375	Bypass voltage rapid inspection abnormal	Bypass voltage Sequence is reverse
376	Bypass overcurrent	Bypass overcurrent
377	ECO bypass overvoltage	Byapss voltage abnormal in ECO model
378	ECO bypass undervoltage rapidly	Byapss voltage abnormal in ECO model
379	ECO bypass overfrequency	Byapss frequence abnormal in ECO model
380	ECO bypass underfrequency	Byapss frequence abnormal in ECO model
381	ECO bypass undervoltage rapidly	Bypass undervoltage rapidly in ECO model
382	ECO bypass phase sequence error	Bypass phase sequence error in ECO model
383	ECO bypass neutra loss	Bypass neutra loss in ECO model
396	Bypass radiator overtemperature	Bypass radiator overtemperature
418	Battery maintenance reminder	Battery maintenance reminder
419	Battery discharging time ended	Battery discharging until time ended
420	Battery discharge voltage ended	Battery End Of Discharge
421	Battery over temperature	Battery over temperature
422	Battery under temperature	Battery under temperature
423	Battery self check fail	Battery Test fails
451	Bypass abnormal	Bypass voltage or frequence abnormal
452	Output abnormal	Output voltage or frequence abnormal
464	Input over voltage	Input voltage abnormal
465	Input under voltage	Input voltage abnormal

466	Input over frequency	Input frequency abnormal
467	Input under frequency	Input frequency abnormal
468	Input phase sequence error	Input phase sequence is reverse
469	Input phase loss	Input phase loss
470	Input voltage imbalance	Input voltage is not balance
471	input voltage rapid inspection abnormal	Output shorted Circuit
472	Input over current	Input over current
473	Input current imbalance	Input current is not balance
474	Input null wire loss	Input Grid Neutral Lost
475	Input fuse failure	Input fuse failure
476	Input power limited	Input power limited
477	Frequent switching between grid and battery	Transfer times (from grid to battery) in 1 hour exceed the limit.
478	Input overload	Input overload
479	Reserved	
480	Battery disconnect	Battery cables Disconnected.
481	Battery overtemperature	Battery overtemperature
482	Battery self check fail	Battery Test fails
483	Battrey overvoltage	Battrey overvoltage
484	Battery undervoltage DOD	Battery voltage is lower than "low voltage warming" point when discharging
485	Battery undervoltage EOD	Battery voltage is lower than "end of discharge" point when discharging
486	Battery over-charging	Battery over-charging
487	Battery temperature low	Battery temperature low
488	Battery hardware overvoltage failure	Battery hardware overvoltage failure
489	Battery charging overcurrent	Battery charging overcurrent
490	Battery discharging overcurrent	Battery discharging overcurrent
491	Open circuit of charger switch	Charger relay is open
492	Charger switch short circuit	Charger relay short circuit
493	Battery discharge overtime	Battery discharge overtime
494	Reverse battery connection	Battery pole (positive and negative)are reverse
495	battery neutral Lost	battery neutral Lost
521	PFC soft start fail	PFC soft start fail
528	Rectifier IGBT module over temperature	Rectifier over temperature
529	Rectifier E2PROM read-write failure	Rectifier E2PROM read-write failure
546	Charger soft start fail	Charger soft start fail
547	Charger over voltage	Charger fail
548	Charger hardware overvoltage failure	Charger fail



549	Charger under-voltage	Charger fail
568	Lithium battery charge primary protection	The charge primary protection of Lithium battery BMS system has been triggered
569	Lithium battery discharge primary protection	The discharge primary protection of Lithium battery BMS system has been triggered
570	Lithium battery charge secondary protection	The charge secondary protection of Lithium battery BMS system has been triggered
571	Lithium battery discharge secondary protection	The discharge secondary protection of Lithium battery BMS system has been triggered
572	Lithium battery charge tertiary protection	The charge tertiary protection of Lithium battery BMS system has been triggered
573	Lithium battery discharge tertiary protection	The discharge tertiary protection of Lithium battery BMS system has been triggered
574	Lithium battery charge warning	Lithium battery charge abnormal
575	Lithium battery discharge warning	Lithium battery discharge abnormal
576	Input abnormal	Input abnormal
592	Bus-bar short circuit	DC bus shorted Circuit
593	Bus-bar abnormal	Bus-bar abnormal
594	Bus-bar overvoltage	DC bus over Voltage
595	Bus-bar under voltage	DC bus under Voltage
596	Bus-bar voltage imbalance	DC bus voltage imbalance
608	Inverter overvoltage	Inverter overvoltage
609	Inverter under voltage	Inverter under voltage
610	Inverter voltage imbalance	Inverter voltage imbalance
611	DC component exceeded	DC component exceeded
612	Inverter module 105% overload	Inverter Over Load 105%Timeout
613	Inverter module 110% overload	Inverter Over Load 110%Timeout
614	Inverter module 125% overload	Inverter Over Load 125%Timeout
615	Inverter module 150% overload	Inverter Over Load 150%Timeout
616	Short circuit of inverter output	Output shorted Circuit
617	Inverter module overload alarm	Inverter Over load
626	BYP 125% overload	BYP Over Load 125%Timeout
627	BYP 135% overload	BYP Over Load 135%Timeout
628	BYP 150% overload	BYP Over Load 150%Timeout
629	BYP 200% overload	BYP Over Load 200%Timeout
630	Bypass overload alarm	Bypass Over load
640	Inverter soft start fail	Inverter soft start fail
641	Phase lock fail	Phase lock fail
642	Frequent switching between bypass and inverter	Transfer times (from inverter to bypass) in 1 hour exceed the limit.
643	Inverter soft start times reached	Inverter soft start times reached
644	Parallel operation current imbalance	Parallel operation current imbalance
645	Capture failure	Capture failure

646	Load strike	Load strike
647	Adjacent UPS request switching to bypass	Adjacent UPS request switching to bypass
648	Parallel operation wire abnormal	Parallel cable in error
649	Driver connection failure	Driver connection failure
650	Synchronous square wave abnormal	Synchronous square wave abnormal
651	Inverter self check failure	Inverter self check failure
656	Inverter radiator over temperature	Inverter Over Temperature
657	Inverter E2PROM operation failure	Inverter E2PROM operation failure
658	Inverter DSP and monitor communication failure	Inverter DSP and monitor communication failure
663	Emergency shutdown	EPO Emergency Power Off
672	Inverter relay open circuit	Inverter relay open circuit
673	Inverter relay short circuit	Inverter relay short circuit
676	SPI communication failure between rectifier and inverter	SPI communication failure between rectifier and inverter
688	Output overvoltage	Output overvoltage
689	Output undervoltage	Output undervoltage
704	inverter fast check fail	inverter fast check fail
705	inverter Negative power fault	inverter Negative power fault

---

## 5. Operations

### 5.1 UPS Start-up

#### 5.1.1 Start from Normal Mode

The UPS must be started up by commissioning engineer after the completeness of installation. The steps below must be followed :

1. Ensure all the circuit breakers are open and the UPS output is not shorted..
2. Close the output circuit breaker (CB) and then the input CB and the system starts initializing. If the system has dual inputs, close both of the breakers.
3. The LCD in front of the cabinet is lit up. The system enters the home page, as shown in Fig.4-2.
4. Notice the energy bar in the home page, and pay attention to the LED indicators.
5. After 30S, Bypass static switch closes then the inverter is starting up.
6. The UPS transfers from the bypass to inverter after the inverter goes normal.
7. The UPS is in Normal Mode. Close the battery circuit breakers and the UPS starts charging the battery.
8. The starting up done.

#### Note

- When the system starts, the stored setting will be loaded.
- Users can browse all incidents during the process of the starting up by checking the menuLog.

#### 5.1.2 Start from Battery

The start for battery model is referring to battery cold start. The steps for the start-up are as follows :

1. Confirm the battery is correctly connected; close the external battery circuit breakers.
2. After 60S, Press the red button located at the back of the UPS cabinet for the battery cold start. The system is powered by the battery.

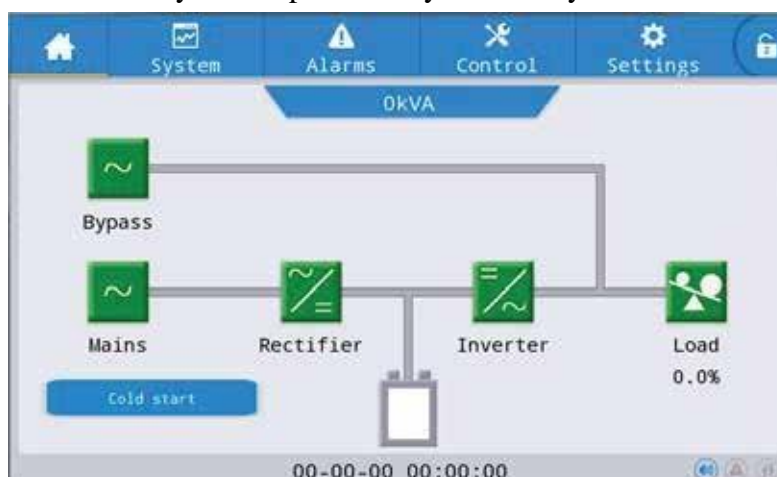

Fig.5-1 Home page

3. After that, Press the button for **cold start** on the LCD, The system is starting up following steps 3 in section 5.1.1 and the system transfers to battery mode in 30S.
4. Close the external output power supply isolation to supply the load, and the system is working on battery model.

---

## 5.2 Procedure for Switching between Operation Modes

### 5.2.1 Switching the UPS into Battery Mode from Normal Mode

The UPS transfers to Battery mode immediately after input circuit breaker disconnects from the utility.

### 5.2.2 Switching the UPS into Bypass Mode from Normal Mode

Follow the path by selecting the icon of “ON” to transfer the system to Bypass Mode.

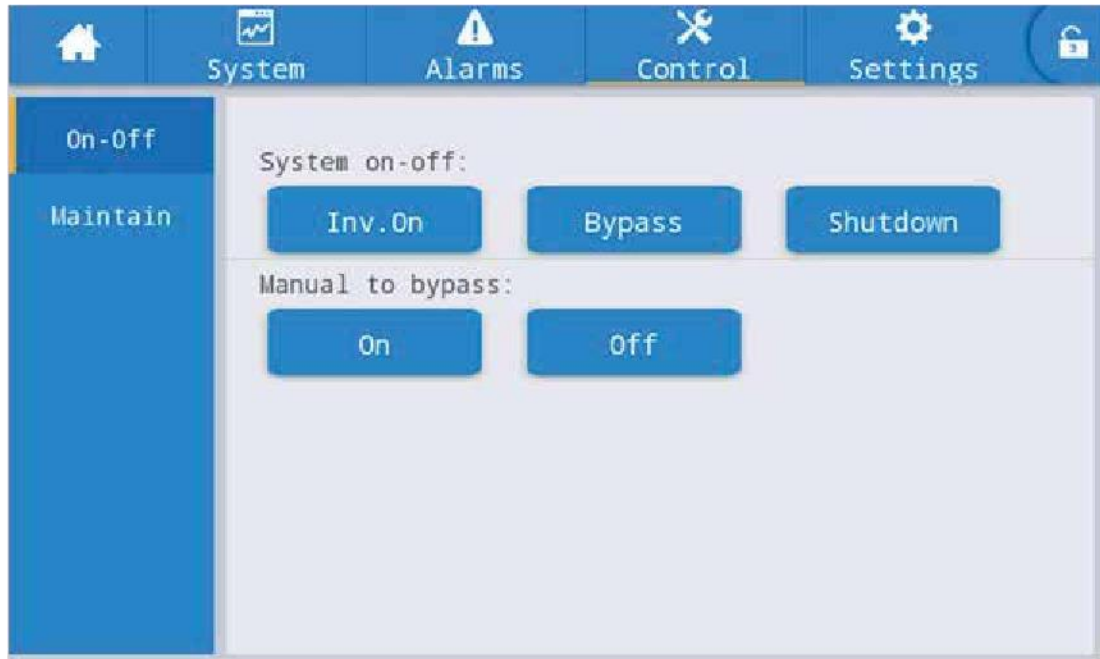

Fig.5-2 Control interface



#### **Warning**

Ensure the bypass is working normally before transferring to bypass mode. Or it may cause failure.

---

### 5.2.3 Switching the UPS into Normal Mode from Bypass Mode

Follow the path by selecting the icon of “Off”, the system transfer to Normal Mode

#### **Note**

Normally, the system will transfer to the Normal mode automatically. This function is used when the frequency of the bypass is overtrack and when the system needs to transfer to Normal mode by manual.

### 5.2.4 Switching the UPS into Maintenance Bypass Mode from Normal Mode

These following procedures can transfer the load from the UPS inverter output to the maintenance bypass supply, which is used for maintaining the UPS.

1. Transfer the UPS into Bypass mode following section 5.2.2.
2. Open the battery breaker and close the maintenance bypass breaker. And the load is powered through maintenance bypass and static bypass.
3. The load is powered through maintenance bypass.



### Warning

Before making this operation, confirm the messages on LCD display to be sure that bypass supply is regular and the inverter is synchronous with it, so as not to risk a short interruption in powering the load.



### Danger

Even with the LCD turned off, the terminals of input and output may be still energized .

If you need to maintain the power module, wait for 10 minutes to let the DC bus capacitor fully discharge before removing the cover.

---

## 5.2.5 Switching the UPS into Normal Mode from Maintenance Bypass Mode

These following procedures can transfer the load from the Maintenance Bypass mode to inverter output.

1. After finish of maintenance, close the bypass breaker and the bypass static switch will be turned on in 30S after the LCD touch screen goes on, the bypass energy bar is ok and the load is powered through maintenance bypass and static bypass.
  2. Turn off the maintenance bypass switch and fix the protection cover, and then the load is powered through bypass. The rectifier starts followed by the inverter.
  3. After 60S, the system transfers to Normal mode.
- 



### Warning

The system will stay on bypass mode until the cover of maintenance bypass breaker is fixed.

---

## 5.3 Battery Maintenance

If the battery is not discharged for a long time, it is necessary to test the condition of the battery.

Enter the menu “maintain”, as is shown in Fig.5-3 and select the icon “Bat Test 2”, the system transfers into the Battery mode for discharging. The system will discharge the batteries until the alarm of “Battery low voltage” is given. Users can stop the discharging by the “Stop Bat Test” icon.

With the icon of “Bat Test 1”, batteries will be discharged for about 30 seconds, and then re-transfer to normal mode.



Fig.5-3 Battery maintenance

---

## 5.4 EPO

The EPO button located on the home page (see Fig.5-4) is designed to switch off the UPS in emergency conditions (e.g., fire, flood, etc.). To achieve this, just press the EPO button, and the system will turn off the rectifier, inverter and stop powering the load immediately (including the inverter and bypass output), and the battery stops charging or discharging.

If the input utility is present, the UPS control circuit will remain active; however, the output will be turned off. To completely isolate the UPS, users need to open the external mains input supply to the UPS



### Warning

When the EPO is triggered, the load is not powered by the UPS. Be careful to use the EPO function.

---

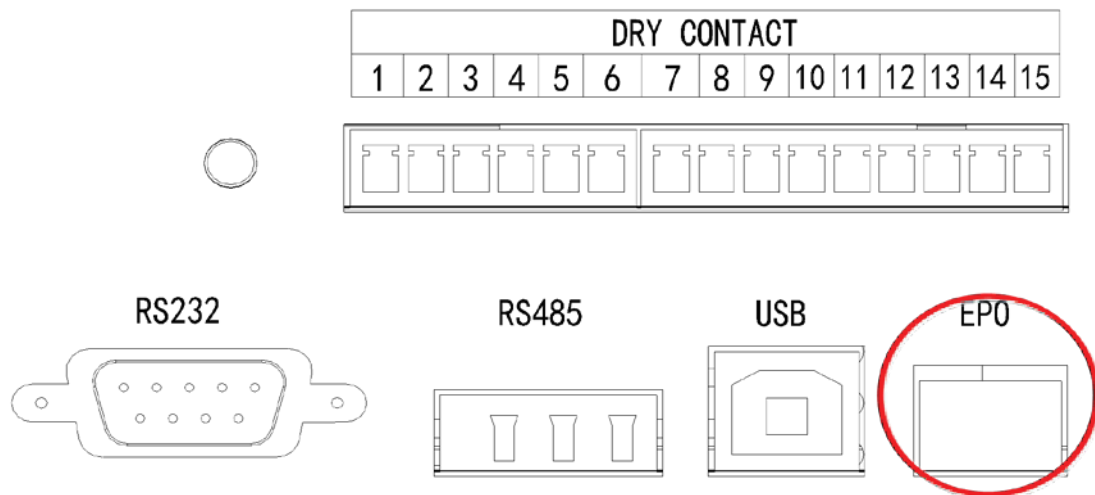

Fig .5-4 EPO

## 5.5 Installation of Parallel Operation System

### 5.5.1 Parallel system diagram

Up to four UPS could be paralleled, with a diagram as shown in Fig.5-5.

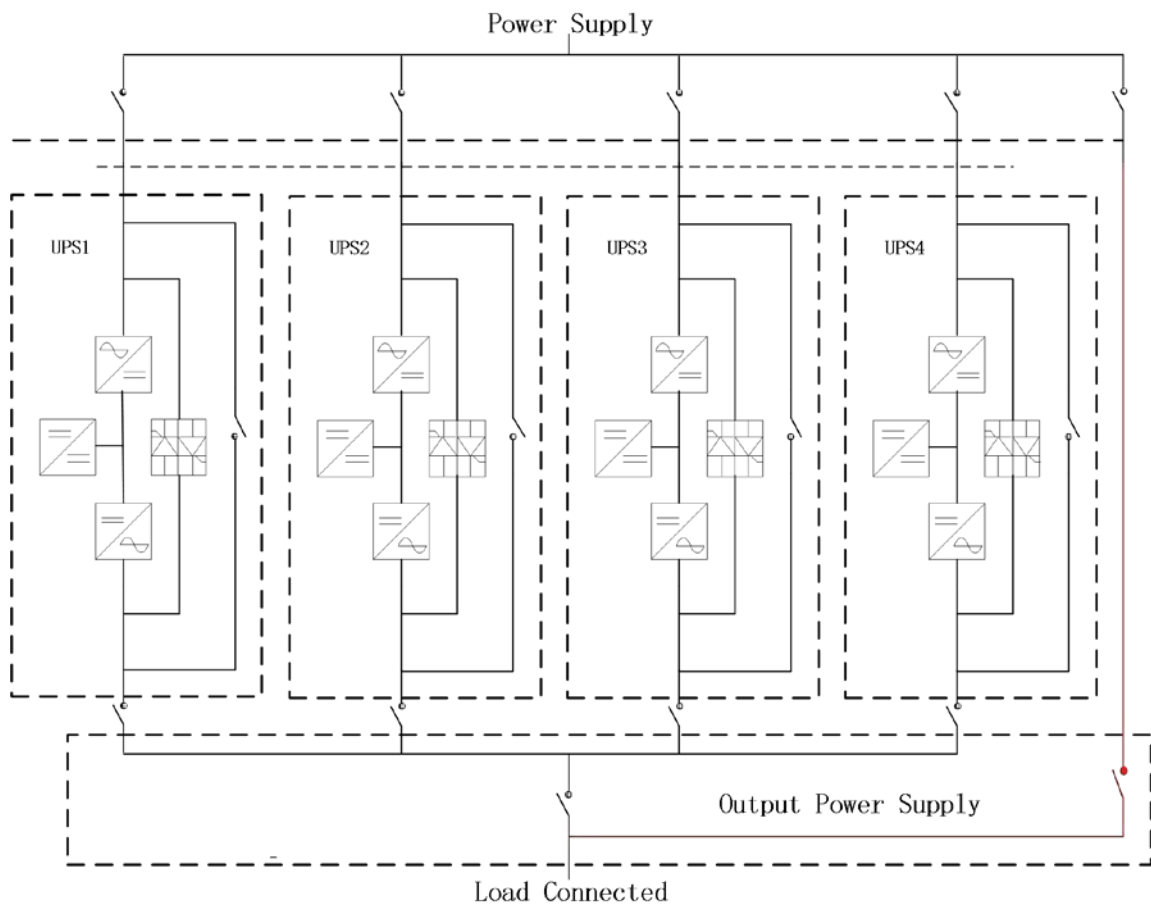

Fig. 5-5 Parallel diagram

The parallel board is located at the back of the UPS cabinet.

All the parallel cables are designed to be shielded and double insulated, and are connected between the UPS to form a loop as shown below in Fig.5-6.

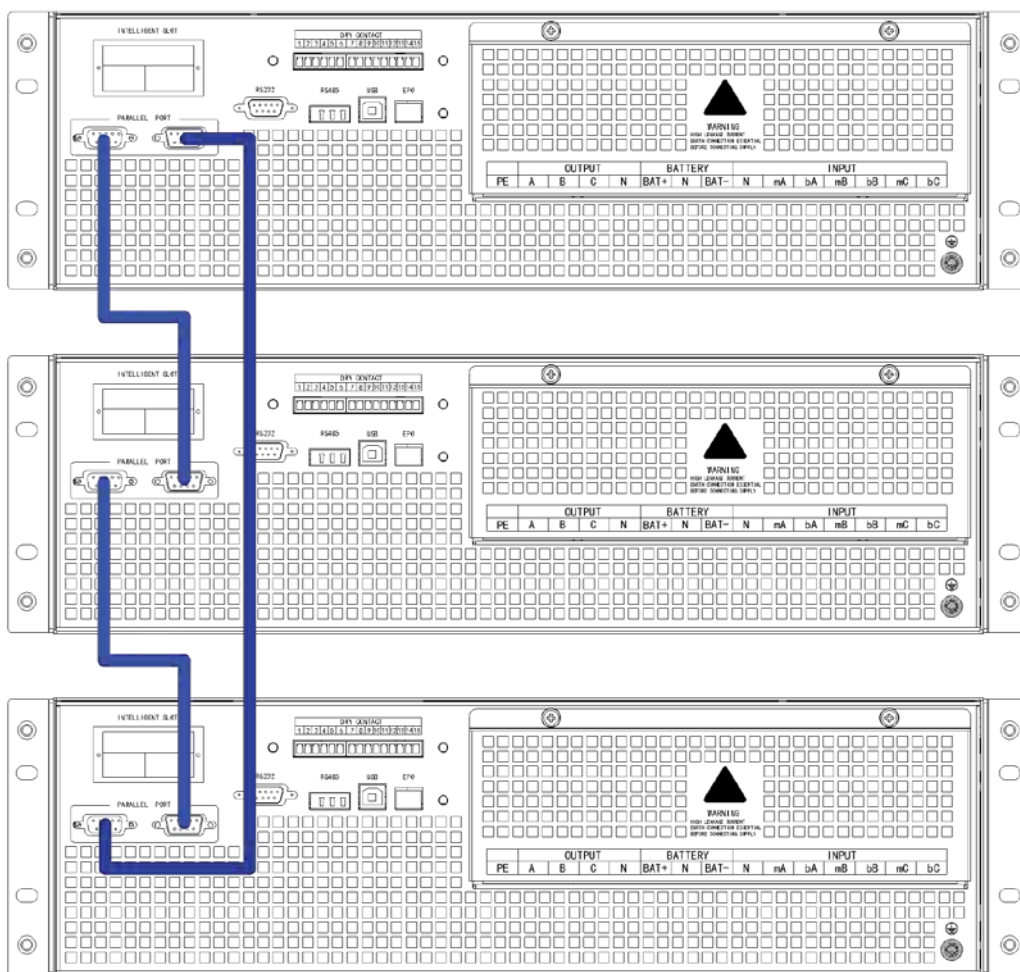

Fig.5-6 Parallel connection

## 5.5.2 Parallel system setting

### Parallel system connection

For field installation, please connect the cables with the same length wire.

In order to assure that all units are equally utilized and to comply with relevant wiring rules, the following requirements apply:

1. All units shall be of the same rating and must be connected to the same bypass source.
2. The bypass and the main input sources must be referenced to the same neutral potential.
3. Any RCD (Residual Current detecting device), if installed, must be of an appropriate setting and located upstream of the common neutral bonding point. Alternatively, the device must monitor the protective earth currents of the system. Refer to the High Leakage Current Warning in the first part of this manual.
4. The outputs of all UPS must be connected to a common output bus.

### Parallel system software setting

To change the parallel system setting, please follow the steps below.

With the monitoring software from manufacturer, select the page of “**Settings**” as below,



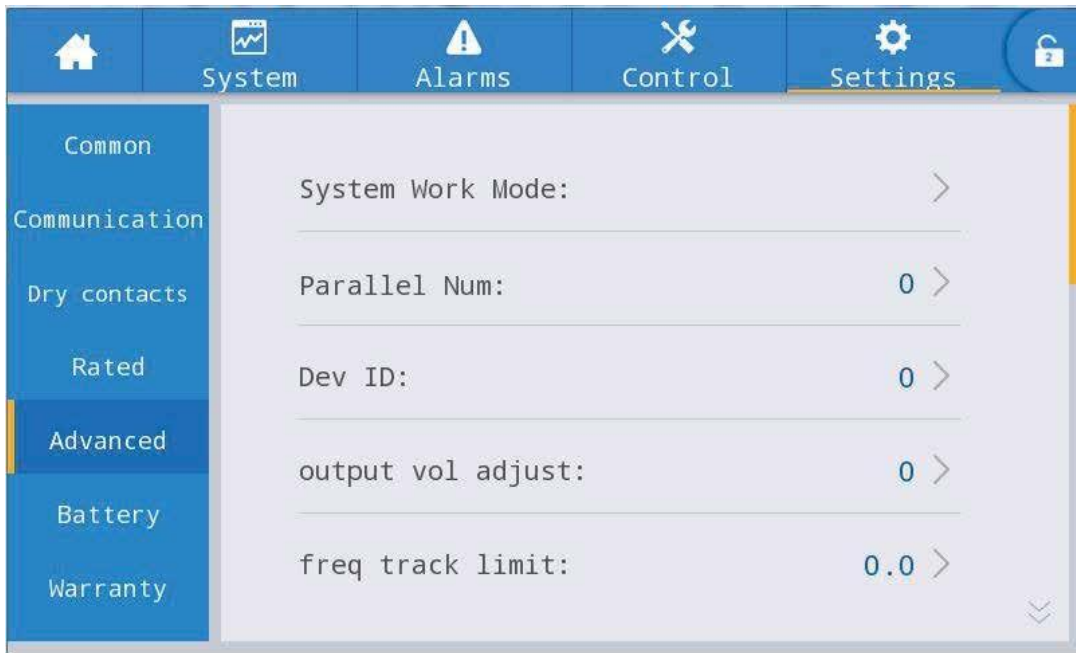

Fig.5-7 parallel setting interface

Set “**System Work Mode**” to “**Parallel mode**”, and set the “**Parallel Num**” to the number of units in parallel. For the setting of **device ID** with a system of 3 units in parallel, for example, set the number from 0 to 2 for these 3 units accordingly.

Restart the UPS when finish the setting. Here the setting is done. Ensure all the output parameters must be set the same.

When all the connection and settings are finished, follow the steps below for the operation of parallel system setup.

1. Close the output and input breaker of the first unit. Wait for the start up of bypass static switch and rectifier, about 90 seconds later; the system will transfer to normal mode. Check if there is any alarm on LCD and verify the output voltage is correct or not.
2. Turn on the second unit as the same operation with the first one; the unit will join the parallel system automatically.
3. Turn on the rest units one by one, and check the information on LCD.
4. Verify the load sharing with a certain load applied.

---

## 6. Maintenance

This chapter introduces UPS maintenance, including the maintenance instructions of power module and monitoring bypass module and the replacement method of dust filter.

### 6.1 Precautions

1. Only certified engineers are authorized to maintain the UPS.
2. The components or PCBs should be disassembled from top to bottom, so as to prevent any inclination from high gravity centre of the cabinet.
3. To ensure the safety before maintaining, measure the voltage between operating parts and the earth with multimeter to ensure the voltage is lower than hazardous voltage, i.e. DC voltage is lower than 60Vdc, and AC maximum voltage is lower than 42.4Vac.
4. Wait 10 minutes before opening the cover of the power module or the bypass after pulling out from the Cabinet.

### 6.2 Instruction for Maintaining UPS

For the maintenance of the UPS, please refer to chapter 5.2.4 for the instruction to transfer to maintenance bypass mode. After maintenance, re-transfer to normal mode according to chapter 5.2.5.

### 6.3 Instruction for Maintaining Battery string

For the Lead-Acid maintenance free battery, when maintenance the battery according to requirements, battery life can be prolonged. The battery life is mainly determined by the following factors:

1. Installation. The battery should be placed in dry and cool place with good ventilation. Avoid direct sunlight and keep away from heat source. When installing, ensure the correct connection to the batteries with same specification.
2. Temperature. The most suitable storage temperature is 20 °C to 25°C. The battery life will be shortened if the battery is used under high temperature or in deep discharging status. Refer to product manual for details.
3. Charging/discharging current. The best charging current for the lead-acid battery is 0.1C. The maximum current for the battery can be 0.3C. The suggested discharging current is 0.05C-3C.
4. Charging voltage. In most of the time, the battery is in standby state. When the utility is normal, the system will charge the battery in boost mode (Constant voltage with maximum limited) to full and then transfers to the state of float charge.
5. Discharge depth. Avoid deep discharging; which will greatly reduce the life time of the battery. When the UPS runs in battery mode with light load or no load for a long time, it will cause the battery to deep discharge.
6. Check periodically. Observe if any abnormality of the battery, measure if the voltage of each battery are in balance. Discharge the battery periodically.



**Warning**

Daily inspection is very important!

Check and confirm the battery connection is tightened regularly, and make sure there is no abnormal heat generated from the battery.

---



**Warning**

If a battery has leakage or is damaged, it must be replaced, stored in a container resistant to sulfuric acid and disposed of in accordance with local regulations.

---

The waste lead-acid battery is a kind of hazardous waste and is one of the major contaminants controlled by government.

Therefore, its storage, transportation, use and disposal must comply with the national or local regulations and laws about the disposal of hazardous waste and waste batteries or other standards.

According to the national laws, the waste lead-acid battery should be recycled and reused, and it is prohibited to dispose of the batteries in other ways except recycling. Throwing away the waste lead-acid batteries at will or other improper disposal methods will cause severe environment pollution, and the person who does this will bear the corresponding legal responsibilities.

## 7. Product Specification

This chapter provides the specifications of the product, including environmental characteristics mechanical characteristics and electrical characteristics.

### 7.1 Applicable Standards

The UPS has been designed to conform to the following European and international standards:

Table 7.1 Compliance with European and International Standards

Item	Normative reference
General safety requirements for UPS used in operator access areas	EN50091-1-1/IEC62040-1-1/AS 62040-1-1
Electromagnetic compatibility (EMC) requirements for UPS	EN50091-2/IEC62040-2/AS 62040-2 (C3)
Method of specifying the performance and test requirements of UPS	EN50091-3/IEC62040-3/AS 62040-3 (VFI SS 111)

#### Note

The above mentioned product standards incorporate relevant compliance clauses with generic IEC and EN standards for safety (IEC/EN/AS60950), electromagnetic emission and immunity (IEC/EN/ AS61000 series) and construction (IEC/EN/AS60146 series and 60950).



#### Warning

This product conforms the EMC requirements for UPS in Category C3 and it is not suitable for medical equipments.

### 7.2 Declaration of Safety conformity and CE marking

TESCOM UPS system is designed and manufactured in accordance with ISO 9001 Quality Management Systems and ISO 14001 Environmental Management System standards. The CE marking indicates compliance with the EEC Directive by the application of the following standards in accordance with the specifications of the harmonized standards:

- 2014/35/EC Low voltage directive
- 2014/30/EC Electromagnetic Compatibility directive (EMC)
- 2011/65/EU (incl. 2015/863/EU) RoHS Directive

### 7.3 Environmental Characteristics

Table 7.2 Environmental Characteristics

Item	Unit	Requirements
Acoustic noise level at 1 meter	dB	58dB @ 100% load, 55dB @ 45% load
Altitude of Operation	m	≤1000, load derated 1% per 100m from 1000m and 2000m
Relative Humidity	%	0-95, non condensing
Operating Temperature	□	0-40, Battery life is halved for every 10°C increase above 20°C
UPS Storage Temperature	□	-40-70

## 7.4 Mechanical Characteristic

Table 7.3 Mechanical Characteristics for Cabinet

Model	Unit	10kVA	15kVA	20kVA	30kVA
Dimension WxHxD	mm	440*130*660	440*130*660	440*130*660	440*130*750
Weight	kg	24	24	24	29
Color	N/A	BLACK,RAL 7021			
Protection Level IEC (60529)	N/A	IP20			

## 7.5 Electrical Characteristics

Table 7.4 Electrical Characteristics

Model	10kH/10kS	15kH/15kS	20kH/20kS	30kH/30kS
Power Rating	10kVA/10kW	15kVA/15kW	20kVA/20kW	30kVA/30kW
Input Rectifier AC input Mains				
Phase	3 Phases + Neutral + Ground			
Rated Input Voltage	380/400/415 (three-phase and sharing neutral with the bypass input)			
Rated Frequency	50/60Hz			
Input Voltage Range	304~478Vac (Line-Line),full load 228V~304Vac (Line-Line),load decrease linearly according to the min phase voltage			
Input Frequency Range	40Hz~70Hz			
Input Power Factor	>0.99			
Input Current THDi	<5% (full non-linear load)			
Bypass Mains Input				
Rated Bypass Voltage	380/400/415Vac (Line-Line)			
Rated Frequency	50/60Hz			
Bypass Voltage Range	Selectable, default -20%~+15% Up limited: +10%, +15%, +20%, +25% Down limited: -10%, -15%, -20%, -30%, -40%			
Bypass Frequency Range	Selectable, ±1Hz, ±3Hz, ±5Hz			
Bypass Overload	125% long term operation 125%~130% 10min 130%~150% 1min 150%~400% 1s >400% , < 200ms			
Current rating of neutral cable	1.7×In			
Switch time (between bypass and inverter)	Synchronized transfer: 0ms			
Inverter Output				
Rated Inverter Voltage	380/400/415Vac (Line-Line)			
Rated Frequency	50/60Hz			
Output Power Factor	1			

Voltage precision	±1%(Linear Load )			
Frequency precision	0.1Hz			
Synchronized Range	Settable, ±0.5Hz ~ ±5Hz, default ±3Hz			
Synchronized Slew Rate	Settable, 0.5Hz/S ~ 3Hz/S, default 0.5Hz/S			
Transient Response	<5% for step load (20% - 80% -20%)			
Transient recovery	< 20ms for step load (20% - 100% -20%)			
Output Voltage THDu	<1% (full linear Load ) <3% (full non-linear load according to IEC/EN62040-3 )			
Inverter Overload	<110%, 60min; 110%~125%,10min; 125%~150%,1s; >150%,200ms			
<b>Battery( Intermediate DC Lin)</b>				
Long run model battery voltage	Rated ± ±240V default, ±120V~±240V			
Standard model battery voltage	±120	±240	±240	±180
Float charge voltage	2.25V/cell(selectable from 2.2V/cell~2.35V/cell) Constant current and floated voltage charge mode			
Equalized charge voltage	2.35V/cell(selectable from : 2.30V/cell~2.45V/cell) Floated current and constant voltage charge mode			
Temperature compensation	3.0(selectable:0~5.0) mV/□/cl			
Charger Voltage precision	≤1%			
Ripple current	≤5%			
Final discharging voltage EOD Voltage (Acid battery )	1.65V/cell(selectable from: 1.60V/cell~1.75V/cell) @0.6C discharge current 1.75V/cell (selectable from: 1.65V/cell~1.8V/cell) @0.15C discharge current (EOD voltage changes linearly within the set range according to discharge current)			
Battery Charging Power Max Current	Selectable from : 1~10A (20% * UPS capacity limited)			
<b>System</b>				
Display	LCD+LED(5 inch touch screen)			
Normal modeEfficiency (dual conversion)	>94.5%	>94.5%	>95%	>95%
Battery discharging efficiency (battery at nominal voltage 480Vdc and full-rated linear load)	>94.5%	>94.5%	>95%	>95%
Interface	Standard:RS232, RS485, USB Option:Programmable dry contact,SNMP,Parallel kit			

---

## 8. Software Download & Installation

( Only for the model with communication port )

**Please follow steps below to download and install monitoring software :**

1. Go to the website <https://www.idbmonitor.com>
2. Click UPSSmartView software icon and then choose your required OS to download the software
3. Follow the on-screen instructions to install the software

AGKK14931 12/2019

**MANUFACTURING COMPANY**

**TITLE** : TESCOM ELEKTRONİK SANAYİ ve TİCARET A.Ş

**ISTANBUL / HEADQUARTERS**

**ADDRESS** : Dudullu Organize Sanayi Bölgesi 2.Cadde No:7 Zemin Kat Ümraniye / ISTANBUL / TÜRKİYE

**PHONE** : +90 (216) 977 77 70 pbx

**FAX** : +90 (216) 527 28 18

**IZMIR / FACTORY**

**ADDRESS** : 10009 Sokak No:1, Ulukent Sanayi Sitesi 35660 Menemen – IZMIR / TÜRKİYE

**PHONE** : +90 (232) 833 36 00 pbx

**FAX** : +90 (232) 833 37 87

**ATHENS / GREECE OFFICE**

**ADDRESS** : Tescom Hellas S.A. 7th Volou Str. 18346, Moschato ATHENS / GREECE

**PHONE** : +30 21095 90 910

**FAX** : +30 21095 90 080

[www.tescom-ups.gr](http://www.tescom-ups.gr) / [info@tescom-ups.gr](mailto:info@tescom-ups.gr)

[www.tescom-ups.com](http://www.tescom-ups.com)

[international@tescom-ups.com](mailto:international@tescom-ups.com) / [support@tescom-ups.com](mailto:support@tescom-ups.com)