



CL110D

UPS

USER MANUAL

INTRODUCTION

Thank you for choosing this product

Our company is specialized in the design, development and production of Uninterruptible Power supplies (UPS)

The UPS described in this manual is a high-quality product, built to guarantee the best performance.

This manual contains detailed instructions on how to use and install the product.

For information on how to use your equipment to its full potential, this manual should be kept close at hand beside the UPS and PLEASE READ BEFORE STARTING TO WORK ON IT!

Copying all or any part of this manual is strictly prohibited unless due authorization has been granted by the manufacturer. In order to improve the product, the manufacturers reserve the right to make changes to it at any time and with no notice.

CONTENTS

I. GENERAL DESCRIPTION	1
CL110D SERIES UPS	1
Cooling	3
Block diagram of the UPS	3
SAFETY WARNINGS	4
Front view of the UPS	5
Rear view of the UPS.....	5
VIEW OF THE CONTROL PANEL	6
II. INSTALLATION.....	6
STORAGE OF THE UPS	6
PREPARATION FOR INSTALLATION	7
PRELIMINARY INFORMATION	7
ELECTROMAGNETIC COMPATIBILITY	7
INSTALLATION ENVIRONMENT.....	8
REMOVING THE UPS FROM PALLET	8
PRELIMINARY CHECK OF CONTENTS	8
INSTALLING THE UPS.....	8
ELECTRICAL CONNECTIONS.....	8
DIAGRAMS OF CONNECTION TO THE ELECTRICAL SYSTEM	8
CABLE SIZES.....	9
CONNECTIONS	9
ALARM RELAY CONNECTIONS.....	9
RS232 CONNECTOR.....	10
EXTERNAL REPO BUTTON.....	11
WIRING PROCEDURE.....	11
PROTECTIVE EARTH.....	12
III. OPERATION	13
DESCRIPTION	13
PROTECTIONS INSIDE THE UPS.....	13
PRELIMINARY OPERATIONS.....	13
POWERING ON FOR THE FIRST TIME	14
Switching On (Normal Operation) The UPS From Off Position.....	14
Switching Off The UPS From On (Normal Operation) Position.....	15
Transferring the load to bypass manually from On (Normal Operation) Position.....	15
Transferring the load to maintenance bypass from On (Normal Operation) Position.....	15
IV. FRONT PANEL	16
DISPLAY	16
MIMIC DIAGRAM.....	16
KEY SYMBOLS	16
DISPLAY MENUS.....	17
STATUS MENU	17
MEASURES MENU	18
ALARMS MENU	19
INFORMATION MENU	19
ADJUST MENU	19
OPTIONS MENU	20
TIME MENU	21
SERVICE MENU	21
COMMAND MENU	22
ALARM CODES.....	23
Status codes.....	25
Fault codes.....	25
ADJUST MENU	27
Optional AUX1 and AUX2 relay function selection.....	27
V. COMMUNICATION INTERFACE AND REMOTE MANAGEMENT	28
VI. Technical specifications.....	31

I. GENERAL DESCRIPTION

CL110D SERIES UPS

To choose the CL110D series as your equipment protector was a wise investment. It includes many features to protect your critical equipments.

Power ranges according to models

Model	Output power
CL110D	10000 VA / 7000 Watt

This unit supplies continuous power to critical loads from AC input or DC battery power. It monitors input , battery ,output voltage and currents , if any one of them is out of tolerance UPS arranges power redundancy automatically.

The main functions of the UPS unit are as follows :

- Increased power quality
- Power factor correction
- Increased noise reduction
- Power blackout protection
- Battery backup power
- Automatic static switching
- Remote monitoring of UPS
- Remote management of power events
- Power event logging

Therefore inclusion of a CL110D uninterruptible power supply (UPS) in an energy backup system provides secure protection against any possible faults in the AC power system.

DESCRIPTION OF THE FUNCTIONS OF THE CL110D UPS

CL110D UPS is a DSP microprocessor controlled UPS, designed to provide backup power from batteries. There are PFC circuit , battery charger ,battery booster ,inverter and static bypass switch system modules in the CL110D series UPS.

PFC circuit provides low THD input current and voltage regulation

Battery charger provides low ripple battery voltage and current limiting for perfect battery charging

Inverter system provides stable frequency and voltage to critical loads ,with low THD (total harmonic distortion)

Bypass system provides redundancy during UPS failures

Features:

- **3 level converter; PFC ,Inverter, Battery booster and charger**
- **Central DSP controlled structure**
- **High efficiency**
- **Rack and tower options**
- **Voltage range selection (220-230-240 volts AC)**
- **Frequency range selection**
- **Separate battery supported RTC (real time clock)**
- **Enhanced diagnostic**

- **INPUT**
 - *IGBT rectifier type input PFC correction*
 - *PI controlled PFC circuit*
 - *Fuse protected input*
 - *Adjustable mains failure limit*
 - *Adjustable mains high limit (switching to battery option)*
- **BYPASS**
 - *Static bypass system*
 - *Split bypass input (OPTIONAL)*
 - *Voltage adaptive load transfer system*
 - *Adjustable bypass input voltage limits*
 - *Adjustable frequency synchronization band*
 - *Maintenance bypass switch (OPTIONAL)*
- **BATTERY**
 - *Flexible battery quantity*
 - *Battery remaining time indicator*
 - *Fuse protected battery group*
 - *Adjustable battery charging current limit*
 - *Total battery voltage high protection*
 - *3 level battery alarm and warning*
 - *Battery deep discharge protection*
 - *Boost and float battery charger modes*
 - *Automatic or manual battery test function (user selectable)*
 - *Internal batteries*
 - *Automatic or manual restart selection after battery autonomy end*
 - *Temperature compensation for battery charging*
- **OUTPUT**
 - *3 level overload protection*
 - *Output current limit (on or off selectable)*
 - *Output fuse protection*
 - *PID control in output voltage regulation*
 - *Isolated short circuit protection from bypass input*
 - *Adjustable output voltage low and high protection*
- **COMMUNICATION and INTERFACE**
 - *RS232 interface*
 - *Interactive control command protection*
 - *NO or NC selectable DRY contacts (standard line failure ,battery low and bypass)*
 - *OPTIONAL programmable relay outputs (AUX1 and AUX2 contacts NO or NC selectable)*
 - *Digital input (OPTIONAL)*
 - *REPO-External remote emergency power off input (NO-NC programmable)*
 - *LCD front panel ,5 buttons ,indicator lamps and buzzer on front panel*
 - *SNMP adaptor for communication (OPTIONAL)*
 - *RS232 serial port multiplexer (OPTIONAL)*
 - *Modbus adaptor (OPTIONAL)*
 - *128 events (5000 alarms) logging with time and date*
 - *RTC clock (separate battery supported)*
 - *Relay simulation from front panel and RS232*
 - *Operation hour-meter*
 - *Service time indicator*
 - *Front panel language selection*
 - *Front panel lamp test function*
 - *Input voltage and frequency ,bypass voltage and frequency ,output voltage and frequency ,cabinet inside temperature ,load percentage ,load current ,battery voltage and current measurements*

Cooling

A cooling fan is installed on the rear panel of the UPS as air outlet (see back view nr:12 item of the UPS) ,and another cooling fan is installed on the front side of the UPS as air inlet (see front view nr:1 item of the UPS). A temperature sensor on the controller board, measures the ambient temperature inside the cabinet and, if the temperature is higher than a predetermined value,UPS produces an overtemperature alarm. The measured cabinet inside temperature is also displayed on the panel and used for changing the battery-charging voltage to compensate for the temperature changes.

Block diagram of the UPS

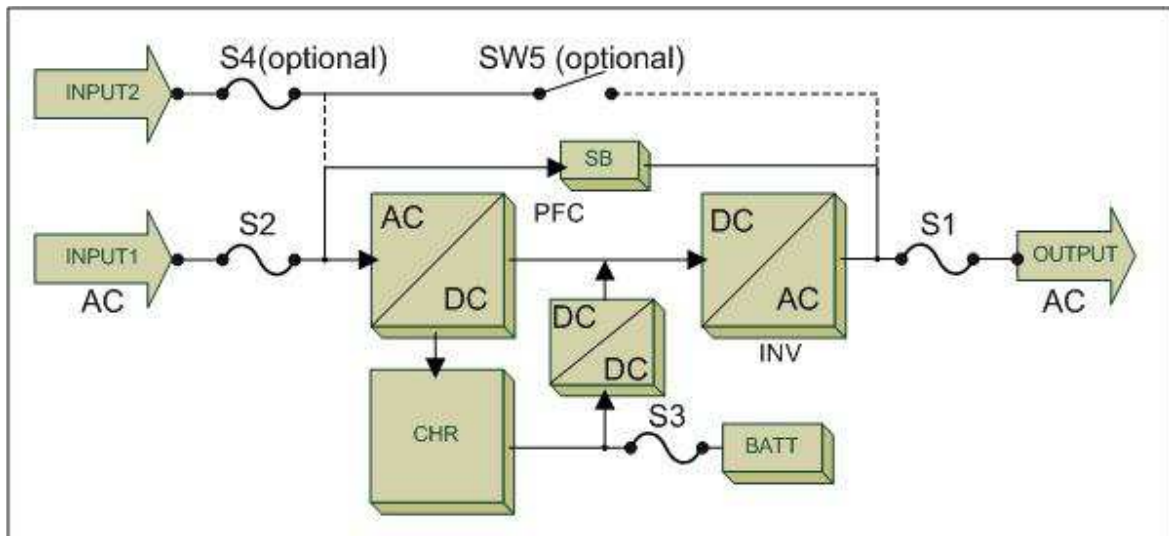

All power stages and switches/fuses of a CL110D model UPS are shown on the above block diagram.

S1	Output switch/fuse
S2	Mains input switch/fuse
S3	Battery input switch/fuse
S4	Bypass input switch/fuse (OPTIONAL)
SW5	Maintenance bypass switch (OPTIONAL)
SB	Static bypass block
PFC	Input power factor correction block
CHR	Battery charger block
INV	Inverter block
BATT	Battery group

SAFETY WARNINGS

IMPORTANT NOTICES

1. This manual must be carefully read before applying any power to the UPS unit.
2. All warnings in the manual should be adhered to.
3. All operating instructions should be followed.
4. The unit should be supplied by a grounded outlet. Do not operate the unit without ground source.
5. Power input cords of the UPS should be routed carefully so that they are not to be walked on.
6. Please save this manual.
7. Please save or recycle the packaging materials.

WARNING !!!

- Do not apply electrical power to the UPS equipment before arrival of authorized service personnel.
- Installation and commissioning of UPS must be performed by a qualified technician.
- Adequate protection against input over currents must be provided, considering the nominal current rating of the UPS.
- Do not insert any object into ventilation holes or other openings.
- To reduce the risk of fire or electric shock, install the unit in temperature and humidity controlled indoor area free of flammable and corrosive substances.
- If input power is connected ,risk of electric shock is valid.
- The unit is powered by more than one power source ,AC input power ,DC battery power ,even when it is in "MAINTENANCE BYPASS" position

WARNING !!!

- **Since it is a high voltage equipment, the UPS contains dangerously high voltages. The risk of contact with these voltages is minimized using special design features and internal safety shields in accordance with IP20 standards.**
- **All maintenance and installation procedures requiring access to the inside of the device must be exclusively performed by trained personnel.**
- **UPS DOES NOT HAVE AUTOMATIC PROTECTION AGAINST VOLTAGE RETURNING TO THE INPUT. POWER SWITCHES OR FUSES OUTSIDE THE UPS MAY HAVE VOLTAGES ON THEIR CONNECTION TERMINALS EVEN WHEN THEY ARE TURNED OFF.**
- **SERVICE PERSONNAL MUST INSULATE THE UPS (BY TURNING OF ITS INPUT,BATTERY and OUTPUT SWITCHES) BEFORE WORKING ON THE UNIT.**
- **Installation and commissioning of this device must be performed by qualified service personal trained and authorized by the manufacturer (or distributor)**
- **Risk of electric shock, do not remove cover. No user serviceable parts inside, refer servicing to qualified service personal.**
- **Risk of electric shock, hazardous live parts inside .**

Front view of the UPS



- 1) Cooling inlet of the UPS
- 2) Control panel
- 3) Power on/off button

Rear view of the UPS



- 4) Emergency Stop
- 5) SNMP Socket
- 6) RS232 communication port
- 7) Cooling outlet of the UPS
- 8) Output switch/fuse (S1)
- 9) Input switch/fuse (S2)
- 10) Battery switch/fuse (S3)
- 11) Maintenance bypass switch (SW5)
- 12) Input, output and battery screw terminals

VIEW OF THE CONTROL PANEL

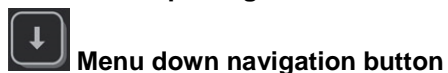
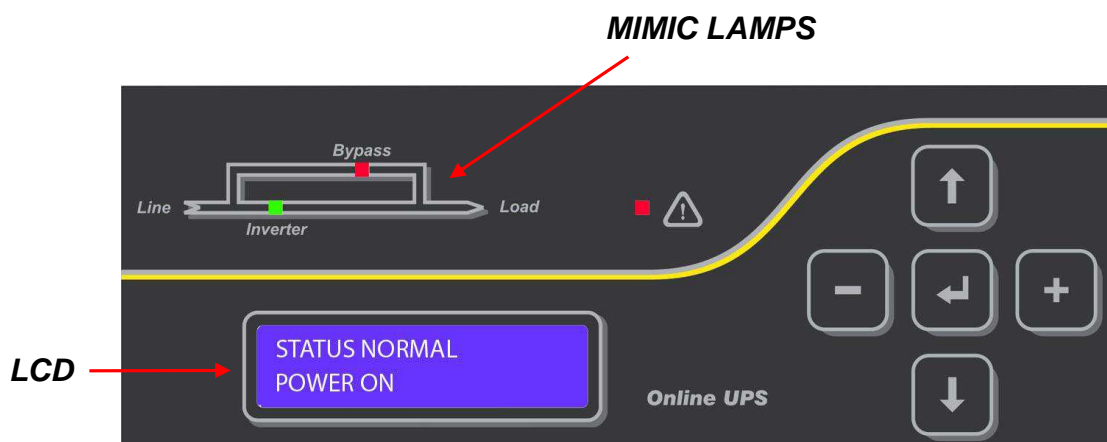

Alphanumeric LCD panel function

1. Line : menu items and measured parameters
2. Line : alarms are shown one after the other as time shared

II. INSTALLATION

ALL THE OPERATIONS DESCRIBED IN THIS SECTION MUST BE CARRIED OUT EXCLUSIVELY BY QUALIFIED TECHNICIANS.

The company may not be held liable for any damage caused by incorrect connections or by operations that are not described in this manual.

STORAGE OF THE UPS

The storage area must have the following characteristics

Temperature : -10 to +50 C

Relative humidity : 95% max.

During storage keep the battery switch always "OFF" (0 position).

PREPARATION FOR INSTALLATION

PRELIMINARY INFORMATION

Model	CL110D
Nominal output power	10000 VA / 7000 Watt
Operating temperature	0 – 40 C
Non operating temper.	-10 to + 50 C
Max.relative humidity	90% (non-condensing) during operation
Max.installation altitude	2000 m at nominal power rating
Dimensions (WxDxH)	215 x 775 x 585 mm
Weight (kgs)	36 (without batteries) 80 (with internal batteries)
Protection level	IP20
Cables inlet	from rear side (screw terminals)
Communication	RS232 standard
LCD panel and mimic	Available - Standard
Software management	Available - Standard
Dry contact outputs	Available - Standard
REPO input	Available – Standard (NO or NC programmable)

ELECTROMAGNETIC COMPATIBILITY

This uninterruptible power supply (UPS) conforms to the class C2 specifications (in accordance with the provisions laid down by the EN62040-2 standard: UPS – EMC requirement). In the home environment, it may cause radio interference. The user may have to take supplementary measures.

This product is designed for professional use in industrial and commercial environments. Connections to the RS232 connectors should be made with the cables provided or, in any case, with shielded cables less than three meters long.

INSTALLATION ENVIRONMENT

When choosing the site in which to install the UPS, the following points should be taken into consideration:

- Avoid dusty environments
- Check that the floor is level and capable of withstanding the weight of the UPS
- Avoid cramped environments that could impede the normal maintenance activities
- The relative humidity should not exceed 90%, non-condensing.
- Check that the ambient temperature, with the UPS running, remains between 0 and 40 C
- Avoid installing the equipment in places exposed to the direct sunlight and hot air.

REMOVING THE UPS FROM PALLET

The UPS is packed and enclosed in a structural cardboard carton to protect it from damage.

1. **Inspect for damage that may have occurred during the shipment. If any damage is noted, call the shipper immediately and retain the shipping carton and the UPS.**
2. Carefully open the carton and take the UPS out.

Retain the carton and packing material for possible future use

PRELIMINARY CHECK OF CONTENTS

Having opened the package, start by checking the contents

- User manual
- CC05 coded serial RS232 connection cable
- UPS manager software and user manual CD-rom
- Guarantee document

INSTALLING THE UPS

When installing the equipment the following points should be considered:

- The air outlet and inlet of the UPS is on the rear and front respectively, because of this do not prevent air ventilation from the rear and front side.
- No objects should be left on its top surface
- Sufficient space should be left in front of the equipment for it to be turned on/off and maintenance operations to be performed on it (>1 m)
- Keep out of your equipment from the explosive and flammable items

ELECTRICAL CONNECTIONS

DIAGRAMS OF CONNECTION TO THE ELECTRICAL SYSTEM

Basic connection (no split bypass input option)

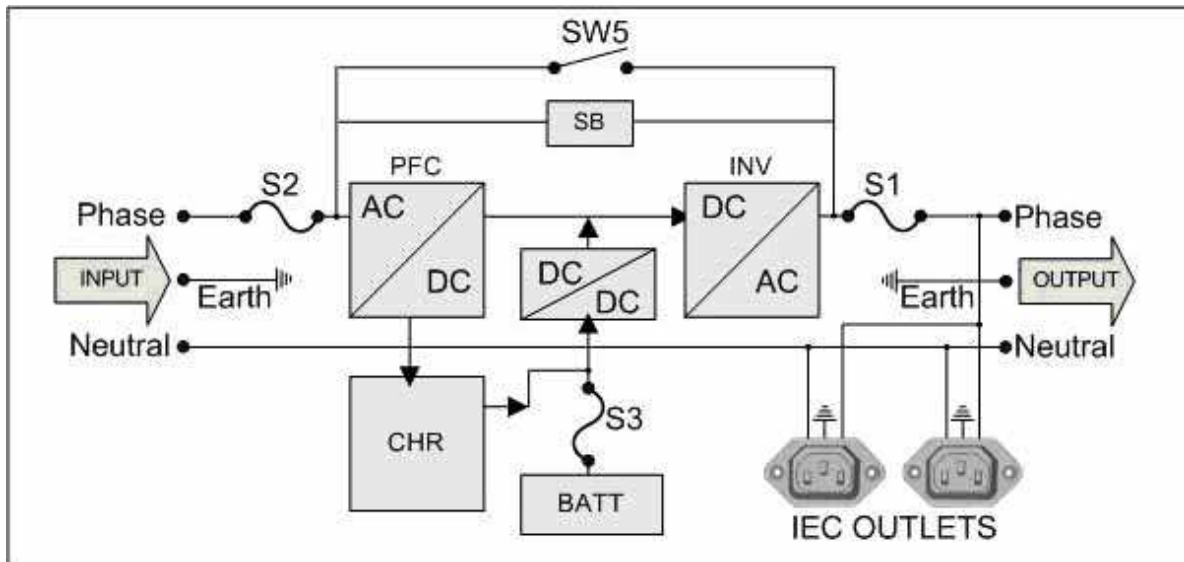

Split bypass connection (OPTION)

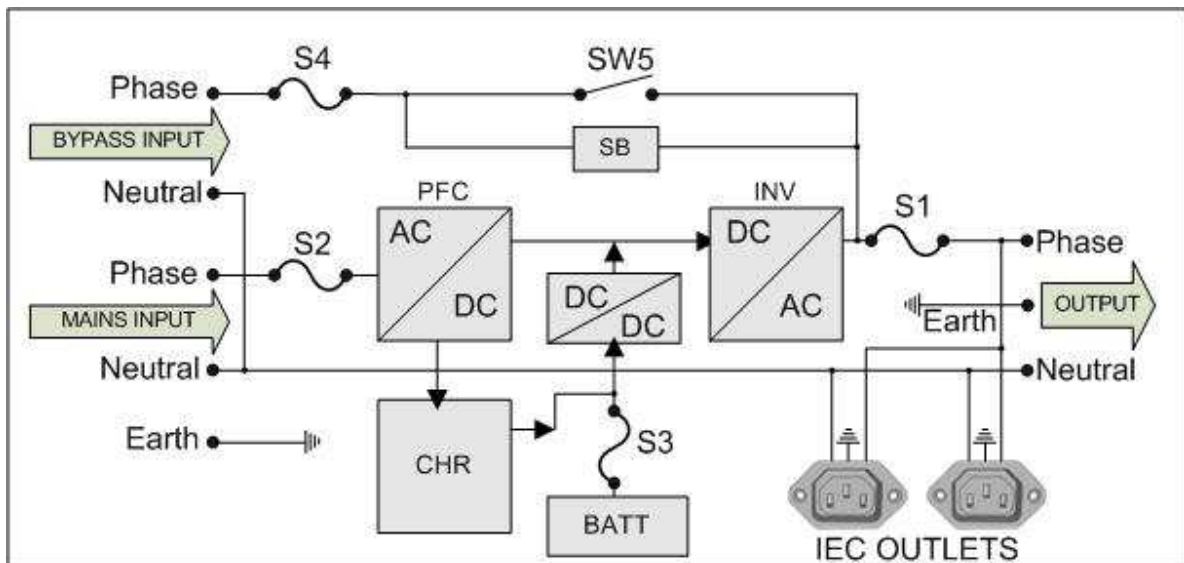

CABLE SIZES / FUSES

The input/output cables can be sized to suit the UPS rating according to the table below

Cables	CL110D
Input	3x10 mm ² (phase+neutral+earth)
Output	3x10 mm ² (phase+neutral+earth)

Fuses	CL110D
Input	63A
Output	63A
Battery	63A

CONNECTIONS

CL110D Series UPS run only on 1-Phase AC power supplies with a NEUTRAL line.
The UPS unit must be grounded in accordance with electrical regulations

Before making power connections to the unit, ensure that the incoming power sources are de-energized and insulated.

The connections of the UPS should be supplied by grounded outlets. All control cables should be screened and run in a separate trunking to the power cables.

AC INPUT AC OUTPUT BATTERY

K1- K2- K3 K4-K5-K6 K7- K8

⏚ Phase Phase ⏚ (+) (-)

Neutral Neutral

Terminal	Function
K1	Earth input terminal
K2	Phase input terminal
K3	Neutral input terminal
K4	Neutral output terminal
K5	Phase output terminal
K6	Earth output terminal
K7	Battery (+) terminal
K8	Battery (-) terminal

ALARM RELAY CONNECTIONS

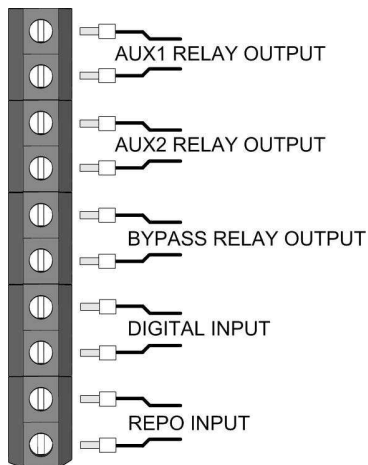

Function	Description
AUX1 RELAY (OPTIONAL)	Function selectable (NO-NC programmable)
AUX2 RELAY (OPTIONAL)	Function selectable (NO-NC programmable)
BYPASS RELAY(OPTIONAL)	Standard connection to RS232 connector (NO-NC programmable)
DIGITAL INPUT	OPTIONAL (Reserved for special applications)
REPO INPUT	Standard Remote Emergency Power Off input (NO-NC programmable)

Bypass relay is standard. The pins of the bypass relay are connected to the RS232 connector, optional screw terminals are parallel with these contacts.

RS232 CONNECTOR

RS232 communication connector of the CL100D series UPS is a D-type , 9 pins ,female type connector. This connector contains dry contact relay outputs and RS232 data pins together. All dry contact pins and RS232 data pins are isolated from UPS circuits.

RS232 hardware	
Baud rate	2400
Connection	3 wire (RX,TX,GND)
Bits	8 bits
Parity	none
Flow	none
Stop bit	1

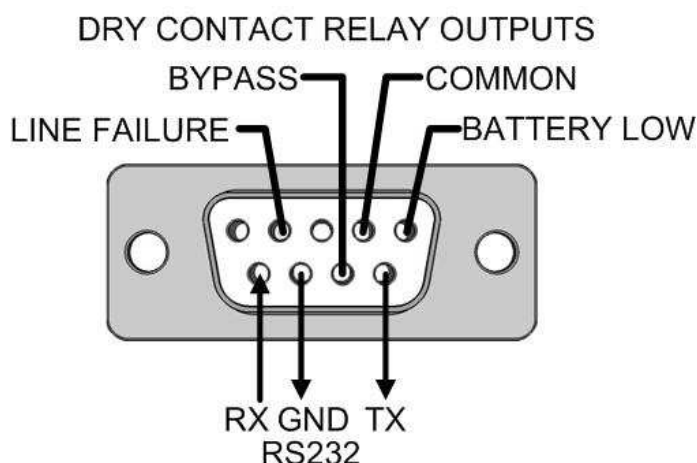

Function	Description
LINE FAILURE	Standard (NO-NC programmable)
BATTERY LOW	Standard (NO-NC programmable)
LOAD ON BYPASS	Standard (NO-NC programmable)

Pin nr.	Description
Pin 2	Line failure alarm dry contact pin
Pin 4	Dry contact common pin
Pin 5	Battery low alarm dry contact pin
Pin 6	RS232 data receive pin
Pin 7	RS232 Ground pin
Pin 8	Bypass alarm dry contact pin
Pin 9	RS232 data transmit pin

EXTERNAL REPO BUTTON

REPO input is the screw terminal pair at the rear next to the RS232 connector. The function of the REPO input can be programmable from ADJUST MENU. The selectable options are:

Function	Description
NO contact	If REPO input terminals are shorted emergency power off will applied
NC contact	If REPO input terminals are opened emergency power off will applied

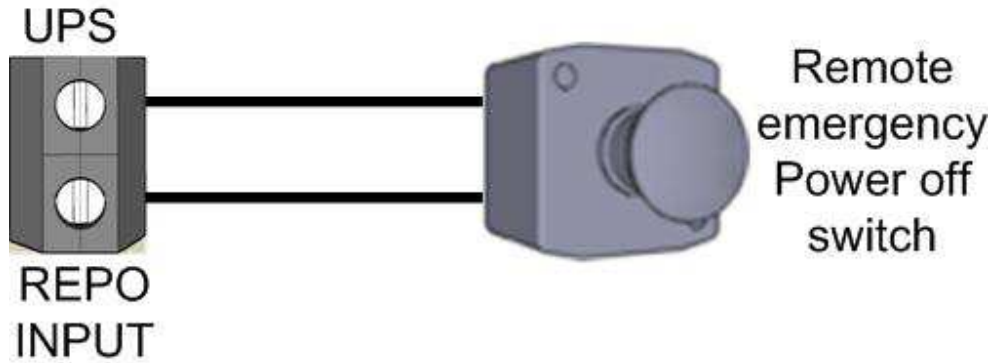

This isolated input is used to turn off the UPS remotely in case of emergency. The UPS is supplied from the factory with REPO terminals open-circuited (see “View of the UPS connections”) if those two (NO) terminals are shorted, UPS shuts-down the output voltage.

In case of emergency ,by activating the stop device, the UPS enters to stand-by mode and powers-off the load completely.

The REPO circuit is self-powered ,no external power supply voltage is therefore required. If the external REPO switch is pressed (at least 1 second) UPS turns off its output.

WIRING PROCEDURE

1. Remove the metal guard on the input/output terminal group and connect phase ,neutral and earth input cables. During connection match phase cable to phase input ,neutral cable to neutral input , earth cable to earth input.

Input Power Connections

2. For output connections you have three outlets at the back of the UPS
 - Two IEC output sockets are available. You can directly plug the load cable into anyone of these outputs.
 - If the output will be connected to the load distribution system directly, you can use screw terminal outputs. During connection of the load, match phase cable to phase output, neutral cable to neutral output, earth cable to earth output terminals.

Reassemble the metal guard removed previously.

Output Connections

3. If external batteries are used , turn off the battery fuse and plug on the battery cable to the external battery socket on the rear panel of the UPS.

External battery connection

4. Also proper control and signal wire connections (alarm relays, REPO etc.) should be made through the screw terminal block shown in figure 11.

Note :These auxiliary cables must be shielded and double insulated. (Recommended cross-section =1mm²)

PROTECTIVE EARTH

The protective earth cable must be connected to the earth connection terminal and bonded to each cabinets in the system and also the earthing and neutral bonding arrangements should be in accordance with the local laws. Proper grounding considerably reduces problems in systems caused by electromagnetic interference.

ATTENTION!!! Failure to follow adequate earthing procedures can result in electric shock hazard to people or risk of fire.

III. OPERATION

DESCRIPTION

The purpose of the UPS is to provide constant power which is in predefined limits. While the input voltage is in acceptable tolerances, UPS converts the AC mains input voltage to DC voltage, then inverter stage will convert to AC output voltage again. If the mains input voltage is not available or out of tolerated limits, the UPS uses the DC power from batteries and generates stable AC output voltage. So the inverter stage always produces stable AC voltage and frequency for supplying critical loads connected to the UPS output.

On the other hand, a static bypass system keeps an AC supply (bypass supply) ready to apply immediately to the output in case of overloads or UPS failures.

PROTECTIONS INSIDE THE UPS

OUTPUT SHORT CIRCUIT PROTECTION

In the event of a fault on the load, like short circuit, UPS shuts-down the output voltage and does not transfer the load to bypass to protect the bypass source. To restart after a short circuit, find out the short circuit on the load side and disconnect it from the output of the UPS. Then restart the UPS again.

OVERLOAD PROTECTION

An electronic overload protection system is available in the UPS. This protection system has 3 levels:
100%-125% load UPS operates for 10 minutes then transfers the load to bypass (adjustable time)
126%-150% load UPS operates for 1 minute then transfers the load to bypass (adjustable time)
If the load is greater than 150% UPS immediately transfers the load to bypass

FUSES

There are some fuses on the UPS:
Power supply fuse (on-board glass fuse)
Static bypass fuse (on-board glass fuse)
Mains input fuse (S2-MCB)
Battery fuse (S3-MCB)
Output fuse (S1-MCB)
OPTIONAL bypass input fuse (S4-MCB)

BATTERY PROTECTION

Deep discharge protection.
Battery charge current limit (adjustable)
Average battery high protection system provides early warning in case of battery over-charge.
A three level battery voltage protection is used in the UPS, the levels are as follows:
9.6 volts per battery / battery low shutdown protection (adjustable)
10.8 volts per battery / battery low warning (adjustable)
14.4 volts per battery / battery high protection (adjustable)

INPUT PROTECTIONS

PFC converter input power is limited against overloads
Input AC voltage high protection (adjustable)
Input AC voltage low protection (adjustable)

OUTPUT PROTECTIONS

Output AC voltage high protection (adjustable)
Output AC voltage low protection (adjustable)
Electronic current limiting at the UPS output.
Output frequency bandwidth protection (adjustable)

BYPASS PROTECTIONS

Bypass input AC voltage high protection (adjustable)
Bypass input AC voltage low protection (adjustable)

OTHER

Cabinet inside temperature high alarm (adjustable)
REPO Emergency Power Off feature.

PRELIMINARY OPERATIONS

- Visual check of the connections
Check that all the connections have been made following the information given in the “Connections” paragraph.
- Check that the switch positions are as follows:
Output Switch (S1) in OFF position
Input Switch (S2) in OFF position
Battery Switch (S3) in OFF position
Optional Bypass Input Switch (S4) in OFF position (If exists)
Optional Maintenance Bypass Switch (SW5) in OFF position (If exists)

POWERING ON FOR THE FIRST TIME

- Turn on input power at external input power distribution box (apply power to input terminals) . Measure the voltages on input terminals (phase to neutral 220,230 or 240V 50Hz nominal)
- Turn on input switch (S2)
- Turn on output switch (S1)

WARNING! AFTER S2 AND S1 ARE TURNED ON, THERE WILL BE BYPASS VOLTAGE ON THE OUTPUT TERMINALS OF THE UPS, EVEN IF THE UPS IS NOT TURNED ON YET!

- Press on power button on front panel , wait and see the UPS control panel is activated and displays some messages.
- Note that during start-up, bypass lamp (red) is turned on indicating that bypass voltage is available on the output terminals. After some time inverter starts operating and the output is switched to inverter (green lamp) for normal operation. Measure the output AC voltage of the UPS on output terminals or on IEC outlets before connecting loads (220,230 or 240V 50Hz depending on the voltage selection).
- See that there is no alarm message or alarm sound on the UPS
- Turn on battery switch (S3).
- At this point according to your application you must select some user options from OPTIONS MENU of the control panel. (UPS front panel functions)
- Any option you may select will be applied immediately. There is no need to turn off and on again the UPS after changing any option.

Switching On (Normal Operation) The UPS From Off Position

- Turn on input switch (S2)
- Turn on output switch (S1)
- If maintenance bypass switch (SW5) is on ,change it to “OFF” (0 position)
ATTENTION! : The Maintenance Bypass Switch (if available) must be used only by qualified service technician during servicing.
- Press power button during UPS off



- And see the front panel lamps on
- Turn on battery switch (S3)
- Check that there is no alarm on front panel

Switching Off The UPS From On (Normal Operation) Position

- Press power button and wait until you hear an intermittent buzzer sound, at his moment the load is transferred to bypass



- Release the power button. UPS will be turned-off after 3 seconds.
- Turn off all switches.

Transferring the load to bypass manually from On (Normal Operation) Position

In commands menu go to <ENT>BYPASS submenu and press ENTER button; the load will be transferred to bypass without interruption. After transfer the message will be changed to <ENT>START

Transferring the load to maintenance bypass from On (Normal Operation) Position

- Power off the UPS by using power button as described above. This way, the load will be transferred to bypass automatically.

(You can also transfer the load to bypass supply using COMMAND MENU as described above)

- On the rear panel of the UPS, turn on the maintenance bypass switch (SW5) (1 position)
Note that a blocking metal piece must be removed to operate the maintenance bypass switch and this should be done only by service technician.
- Turn off all other switches (S1, S2 and S3)

IV. FRONT PANEL

DISPLAY

At the center of the control panel, there is a 2 lines/16 alphanumeric characters display, which provides a detailed overview of the current status of the UPS. Directly from front panel you can control the UPS, monitor the electrical values of the inputs, output etc..and change the main settings.

The LCD display has 2 lines and the functions of lines are as follows:

First line: Operation status, menu items and measured parameters

Second line: Time shared indication of alarms

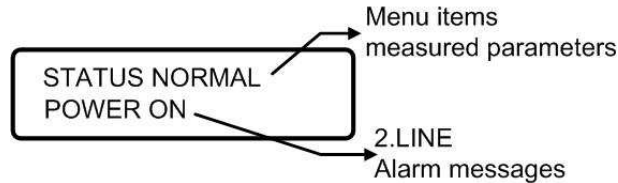

The tag AXX at the beginning of the alarm message on the second line, is the standard alarm code for a particular alarm condition. The remaining message part can be different in each language, but the alarm code is always the same regardless of the selected display language.

MIMIC DIAGRAM

There are two lamps on the mimic panel and one lamp for alarm indication on the control panel of the UPS.

On the mimic panel: Red LED->Bypass, Green LED->Inverter.

Alarm indication : Red LED

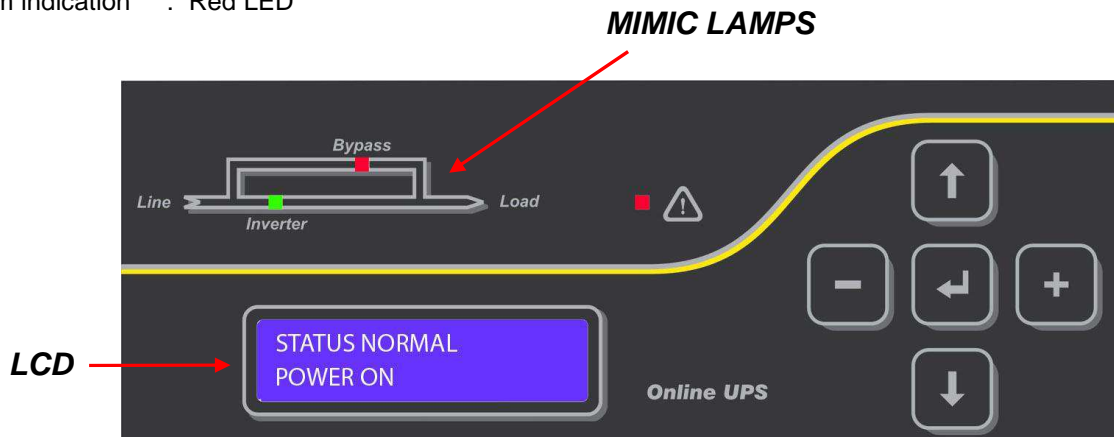

KEY SYMBOLS

There are 5 control keys which provide flexible move on menus, these are:



ENTER button to enter menu or to confirm a selection



Move 1 step down on menu



Move 1 step up on menu



Move on options or move cursor to right 1 step



Move on options or move cursor to left 1 step

DISPLAY MENUS

The function of LCD panel is arranged as a 2 level menu structure.

- Main menu
- Sub menus

STATUS MENU

POWER OFF	Messages displayed by order of priority
FAULT ! 140	
WARNING ! 015	
ALARM !	
WARNING !	
WARNING ! 600	
PFC START !	
INVERTER START !	
STATUS NORMAL !	

POWER OFF

User pressed power button for about three seconds during UPS operation. If the user releases the button, UPS will be turned off after three seconds.

FAULT ! 140

A fault has occurred in the UPS and the number shows the fault code.

WARNING ! 015

Shutdown process started and UPS will be shutdown (sleep mode) after the indicated delay or UPS is in sleep mode and output voltage will be restored after the indicated delay.

ALARM !

An alarm has occurred in the UPS, inverter has stopped but it will start again.

WARNING !

A warning status occurred

WARNING ! 600

An overload alarm has occurred, the load will be transferred to bypass after the indicated delay (in terms of seconds) and inverter will stop after the indicated delay.

PFC START !

Input power factor correction stage has started.

INVERTER START !

Inverter stage has started

STATUS NORMAL !

There is no fault ,alarm or warning and the load is transferred to the output of the UPS.

MEASURES MENU

LOAD:025% 05.0A		Use Up and Down buttons to move on submenu
OUT.:230V 50.0Hz		
BYP.:230V 50.2Hz (option)		
LOAD CF.: 1.4		
INP.:240V 49.9Hz		
I/P CURR.: 18.5 A		
BATT:257V +0.50A		
BAT. TIME: - - - mn		
TEMP: +025 C		
<ENT>EXIT		

From this menu users can see all measured parameters of the UPS. The submenu items are listed as follows by order of appearance.

LOAD:025% 05.0A

Output load percentage and output load current in amperes

OUT.:230V 50.0Hz

Output AC voltage and frequency in Hertz

BYP.:230V 50.2Hz

Bypass AC input voltage and bypass input frequency in Hertz

(This submenu is available only if split-bypass option is selected)

LOAD CF.: 1.4

Load crest factor measurement. For linear loads the crest factor is 1.4 ,for nonlinear loads the value is bigger then 1.4. The UPS can supply bigger peak output current to the load according to RMS current. The maximum crest factor is 3.

INP.:240V 49.9Hz

Rectifier AC input voltage and rectifier input frequency in Hertz

I/P CURR.: 18.5 A

UPS rectifier input current in amperes

BATT:257V +0.50A

Total battery DC voltage in volts and battery charge current in amperes.

BAT. TIME: - - - mn

Remaining battery time during battery operation in terms of minutes.

TEMP: +025 C

Cabinet inside temperature

<ENT>EXIT

If the user presses ENTER button, exits from measures menu.

ALARMS MENU

The most important function of the UPS is alarms menu. There is a real time clock in the UPS and the UPS records all events by their date and time. And the user can see all previous events and alarms by order of occurrence. Every log record contains 16 alarms, 16 warnings and 30 fault and status messages.

000>101009 10:30 This is the last recorded alarm on 10-10-2009 date, at 10:30 and the event number is 000. The second line shows alarm or alarms time shared by order which were recorded at that time.

If the user presses the left or right buttons, the event number will change from 000 to 127, the message which have 000 number is the last event and the 127 is the first (oldest).

<ENT>CLEAR LOGS (ENTER: CLEAR LOG EVENT TABLE)

If the user presses enter key during this message, UPS will clear all recorded events from memory.

Note : For log table clearing service password is required. Otherwise the user can not clear log events.

In this case **LOG.CLEAR FORBID** message will be shown on submenu item.

<ENT>EXIT

If the user presses ENTER button, exits from measures menu to upper menu.

INFORMATION MENU

SYNC:OK COMM:OK		Use Up and Down buttons to move on submenu
POWER:10000VA		
FIRM:D100		
MODEL:CL110D		
BATTERY NR: 020		
CHGR.CURR.:1.50A		
<ENT>EXIT		

SYNC:OK COMM:OK

SYNC:OK indicates that inverter output is synchronous to the bypass input, **COMM:OK** indicates that, RS232 serial communication port is active.

POWER:10000VA

The maximum output power of the UPS in VA.

FIRM:D100

The firmware version of the UPS.

MODEL:CL110

The model name of the UPS.

BATTERY NR: 020

Selected number of batteries for the UPS .

CHGR.CURR.:1.50A

Selected battery charging current limit value in amperes.

<ENT>EXIT

If the user presses ENTER button, exits from alarms menu.

ADJUST MENU

The submenu items of this menu and their functions are described in the service manual of the CL110D series UPS. Please refer to this document.

OPTIONS MENU

This menu contains user adjustable operating modes, options and parameters. These are as follows:

LANG: ENGLISH or TURKISH

This option determines the front panel language of the UPS.

OP.MODE: ONLINE or OFFLINE

OPTION	DESCRIPTION
ONLINE	Online operating mode is selected and the load is continuously connected to the inverter output
OFFLINE	The load is connected to bypass input while bypass input voltage is in tolerances. If bypass input voltage is out of tolerance, the load will be transferred to the inverter output.

RESTART: ON or OFF

OPTION	DESCRIPTION
ON	After battery autonomy-end, following the mains restoration UPS restarts automatically.
OFF	After battery autonomy-end, following the mains restoration the user should restart the UPS.

REMOTE: ON / OFF (REMOTE CONTROL FROM RS232: on/off)

This option enables or disables the remote control of UPS through its serial port.

OPTION	DESCRIPTION
ON	The control options of UPS is enabled from serial port (login required)
OFF	The control options of UPS is disabled from serial port (read only)

BATT.TEST: ON or OFF

This option enables or disables the automatic battery test function of the UPS.

OPTION	DESCRIPTION
ON	Automatic battery test every 72 hours. (first test will be done after 8 hours following the power on)
OFF	UPS cancels automatic battery test

BOOST: ON or OFF

This option enables or disables the boost charge function of the UPS

OPTION	DESCRIPTION
ON	From command menu user can start boost charge for 10 hours
OFF	Command menu boost charge start function is disabled

CHARGE+PFC: NO or YES

This option determines charger will run together with PFC system or stand alone charger system.

OPTION	DESCRIPTION
NO	Charger runs independent from PFC system
YES	If the PFC system stops the charger will stop too. If PFC system starts the charger will start again.

DATA:RS232 or ADAPTOR

Advanced data adaptor is internal type or external type.

OPTION	DESCRIPTION
RS232	RS232 port selection for data transfer
ADAPTOR	Optional adaptor selection for data transfer

RELAYS:NO or NC

Dry contact relay outputs on RS232 connector and on other connectors are NC (normally closed) or NO (normally open) type

OPTION	DESCRIPTION
NO	Relays will be energized if the related alarm occurs
NC	Relays will be de-energized if the related alarm occurs

TEMP.COMPENS:ON/OFF (Battery temperature compensation on/off option)

OPTION	DESCRIPTION
ON	The battery float-charging voltage is changed according to battery cabinet temperature
OFF	The battery float- charging voltage is fixed.

<ENT>EXIT

If the user presses ENTER button, exits from options menu.

TIME MENU

From this menu user can see and set the time and date settings of RTC of the UPS.

TIME: 13:15	Current time of the RTC clock
DATE:10/01/2007	Current date of RTC clock
SET HOURS: 13	press left and right buttons to change the current hours (0 to 23)
SET MINS: 15	press left and right buttons to change the current minutes (1 to 59)
SET DAY: 10	press left and right buttons to change the current day of the month (1 to 31)
SET MONTH: 01	press left and right buttons to change the current month of the year (1 to 12)
SET YEAR:2007	press left and right buttons to change the current year (2000 to 2099)
<ENT> :UPDATE	press enter to update the last date and time settings on UPS RTC clock
<ENT> EXIT	If the user press ENTER button exits from time menu to upper menu

SERVICE MENU

Some maintenance information and service functions are included to this menu.

HOURMTR: 12030		<p>Use Up and Down buttons to move on submenu</p>
NEXT SERVC: 15000		
<ENT>RST.SERVIC		
MAX.LOAD: 075 %		
<ENT> BATT.TEST		
TO B.TEST 040 Hr		
<ENT> BOOST CHG		
SIMULATION:OFF		
ENTER: FAULT RST		
<ENT>EXIT		

HOURMTR: 12030

Operating hour meter of the UPS (not resettable)

NEXTSERVC: 1000

This number indicates the remaining time until the next scheduled service in terms of hours. The UPS creates a warning if this number is zero or negative. This value can be set by service personal when service password is entered. A negative number indicates that the service time is expired by given hours.

<ENT>RST.SERVICE

If enter button is pressed when there is a SERVICE TIME warning, the message will be cleared from the second line of LCD also the sound will be off.

A23 SERVICE TIME message will be shown on LCD while there is no alarm at the UPS. At the same time 3 beep sounds will be heard once every one hours indicating that the service time message has already been shown on the LCD.

MAX.LOAD: 075 %

The maximum output load percentage. If ENTER button is pressed, the old value will be cleared and the maximum load value will be hold until the next clear or power on event.

<ENT> BATT.TEST

In some cases, some other messages may be shown in this menu sub item. These are:

message	description
B.TEST DISABLED	By some reason, battery test function is off.
PERFO.TEST:250 V	UPS is performing battery test and the numbers shows total battery voltage

TO B.TEST 040 Hr

The remaining time to the next battery test in hours. (40 hours later, battery test will be performed)

<ENT> BOOST CHG.

In some cases, some other messages may be shown in this menu sub item. These are:

message	description
BOOST DISABLED	By some reason, boost charge function is off
STOP BOOST>015m.	Charger is in boost charge mode and the remaining time to float charge in minutes.

SIMULATION: OFF

To check relay functions this menu provides simulation for dry contact relay functions

SIM:LINE FAIL. Energizes the line failure relay for test purpose

SIM:LF+BAT.LOW Energizes the line failure and battery low relays for test purpose

SIM:BYPASS Energizes the bypass relay for test purpose

SIM:AUX1 Energizes the optional aux1 relay for test purpose

SIM:AUX2 Energizes the optional aux2 relay for test purpose

ENTER:FAULT RST.

Enter button resets any UPS fault and restarts the UPS.

<ENT>EXIT

If the user presses ENTER button, exits from service menu..

COMMAND MENU

From this menu user can apply immediate commands to the UPS.

SOUND.: ON		Use Up and Down buttons to move on submenu
<ENT> BYPASS		
<ENT>CANCEL SHUT		
<ENT>LAMP TEST		
<ENT>EXIT		

SOUND: ON or OFF

Each pressing to ENTER button will change the alarm buzzer enable(on) or disable(off) status.

<ENT> BYPASS

If the user presses the ENTER button, UPS transfers the load to bypass. During bypass **<ENTER>START** message is shown instead, meaning that ENTER button will start the inverter and transfers the load to inverter again.

<ENT>CANCEL SHUT

If shutdown process is active ,ENTER button cancels the shutdown. The shutdown process is controlled via RS232 port.

<ENT>LAMP TEST

ENTER button starts panel lamps test function. At the same time during test , buzzer beeps.

<ENT>EXIT

If the user presses ENTER button, exits from command menu..

ALARM CODES

The following table shows the alarm and warning messages of the UPS. If an alarm occurs, inverter stops and the load is transferred to bypass. If a warning message occurs, inverter continues its operation.

Message	class
A7 BATTERY LOW	Warning
A7 BAT.LOW SHUT.	Alarm
A8 OUTPUT HIGH	Alarm
A9 OVLD.SHUTDOWN	Alarm
A9 OVERLOAD	Warning
A10 LINE FAILURE	Warning
A11 OVERTEMP.	Warning
A12 OVERCURRENT	Alarm
A13 OUTPUT LOW	Alarm
A14 BATTERY HIGH	Alarm
A16 BYP INP.BAD	Warning
A17 BAT.CB OPEN	Warning
A19 BATT.FAULT	Warning
A20 BOOST CHARGE	Warning
A22 OUTPUT OFF	Warning
A23 SERVICE TIME	Warning
A42 BATTERY TEST	Warning
A48 STATIC BYP	Warning

Message	class
A51 MAINTENANCE	Alarm
A52 MANU.BYPASS	Alarm
A63 INV.FAILURE	Alarm
A65 MAINS HIGH	Warning
A66 +DC BUS TOL	Alarm
A72 AV.BATT.HIGH	Warning
A76 -DC BUS TOL	Alarm
A77 BYP. FREQ. BAD	Warning

A7 BATTERY LOW warning

Battery voltage is less than the minimum allowed warning value. During this alarm inverter continues its operation.

A7 BAT.LOW SHUT.

Battery voltage is less than the minimum allowed shutdown level value. During this alarm inverter stops.

A8 OUTPUT HIGH

Inverter output voltage is higher than the maximum allowed AC voltage value.

A9 OVLD.SHUTDOWN

The output load current is higher than 100% capacity of the UPS

- The load is higher than 150%
- Or, during the last 60 seconds (adjustable) the load is higher than 125%
- Or, during the last 600 seconds (adjustable) the load is higher than 100%

A10 LINE FAILURE

Mains voltage is lower than the allowed minimum AC voltage level or a blackout occurred on mains voltage.

A11 OVERTEMP.

Cabinet inside temperature of the UPS is higher than the allowed temperature. (default 48 C)

A12 OVERCURRENT

Internal or external overcurrent sensed in power drive system.

A13 OUTPUT LOW

UPS tries to regulate the output voltage but the AC output voltage is less than the allowed minimum level.

A14 BATTERY HIGH

The battery voltage is higher than the allowed value.

A16 BYP INP.BAD

The bypass input of the UPS is out of tolerance.

A17 BAT.CB OPEN

The battery fuse is off or blown.

A19 BATT.FAULT

During battery test battery fault occurred.

A20 BOOST CHARGE

UPS is applying boost charge.

A22 OUTPUT OFF

There is no output voltage at the output of the UPS.

A23 SERVICE TIME

The service time indicator was adjusted during the last service and UPS working-hour has reached this value . This warning means that the routine maintenance time is now. The maintenance includes dust cleaning ,battery maintenance, etc.

A42 BATTERY TEST

UPS is performing battery test

A48 BYPASS

UPS has transferred the load to bypass supply for some reason.

A51 MAINTENANCE

Maintenance bypass switch is on.

A52 MANU.BYPASS

Manual bypass has been applied from the front panel (commands menu)

A63 INV.FAILURE

Control system created waveform regulation error.

A65 MAINS HIGH

Mains input voltage of the UPS is higher than the allowed level.

A66 +DC BUS TOL

Positive DC bus of the UPS is out of tolerance, but it tries three times to restart. If it fails it will create a fault.

A72 AV.BATT.HIGH

Battery average voltage is higher than nominal value. The average battery high system provides early warning about battery charger events. Normal battery high alarm system level is quite high and it gives warning possibly after some damage to batteries has occurred. Average voltage system gives early warning to the user. (If each battery voltage is higher than 13.7 volts DC for 10 seconds UPS creates A72 warning)

A76 -DC BUS TOL

Negative DC bus of the UPS is out of tolerance, but it tries three times to restart. If it fails it will create a fault.

A77 BYP. FREQ. BAD

Bypass frequency is out of tolerance.

Status codes

POWER ON
WAITING SHUTDOWN
WAITING RESTART
UPS SHUTDOWN

POWER ON

This message is used in log records. This message indicates the UPS power on time and date in log events list.

WAITING SHUTDOWN

From RS232 a shutdown control command has been received, and after a delay UPS will be shutdown (sleep mode)

WAITING RESTART

Shutdown and restart command received from SR232 port .UPS is already in sleep mode (output shutdown) and after a delay UPS will restart.

UPS SHUTDOWN

Shutdown command has been received from SR232 port. UPS is already in sleep mode and it will stay in this status.

Fault codes

The following table shows fault codes and messages of the UPS. If any one of these fault codes is shown at the second line of LCD panel, the UPS operation has already been blocked. To restart the UPS, from SERVICE menu go to <ENT> FAULT RESET menu item and press ENTER button. If UPS restarts and alarm is cleared, it means that the fault is temporary and now there is no problem. But, on the other hand, if UPS gives the same fault message again, refer to your local service company.

Message	code	status
F1 CHARGER FAULT	134	UPS system blocked load on bypass
F2 4-OVERTEMP.	135	UPS system blocked load on bypass
F3 BATT AUT END	136	UPS stop, load shutdown ,restart at mains OK
F4 REPO STOP	137	UPS system blocked load shutdown
F5 +DC BUS TOL	138	UPS system blocked load on bypass
F6 -DC BUS TOL	139	UPS system blocked load on bypass
F7 NO POWER	140	UPS system blocked load shutdown restarts at mains OK
F8 PFC TIMEOUT	141	UPS system blocked load on bypass
F9 DC BUS ????	142	UPS system blocked load on bypass
F10 BOOSTER SOFT	143	UPS system blocked load shutdown
F11 DC BUS ERROR	144	UPS system blocked load on bypass
F12 SHORT CIRC.	145	UPS system blocked load shutdown
F13 WAVEFORM	146	UPS system blocked load on bypass
F14 BATT.SAMPLE?	147	UPS system blocked load on bypass
F15 4-INV FAIL	148	UPS system blocked load on bypass
F16 4-OVERCURR.	149	UPS system blocked load on bypass
F17 MIS-FUNCTION	150	UPS system blocked load on bypass
F18 ALT.PROTECT.	151	UPS system blocked load on bypass

F1 CHARGER FAULT

Charger system failed

F2 4-OVERTEMP.

A11 OVERTEMP. Alarm has occurred 4 times within 60 minutes. Possible cooling problem of the UPS.

F3 BATT AUT END

During line failure , batteries are discharged fully and already no power on the UPS. After mains is restored the RESTART:ON/OFF option determines whether the UPS is restarted automatically or restarted by the user manually.

F4 REPO STOP

External remote emergency power off signal applied to UPS , currently system shutdown.

F5 +DC BUS TOL

Positive DC bus voltage is out of tolerance alarm has occurred 4 times within 60 last minutes.

F6 -DC BUS TOL

Negative DC bus voltage is out of tolerance alarm has occurred 4 times within 60 last minutes.

F7 NO POWER

UPS started during mains failure but battery voltage is low and the UPS can not start.

F8 PFC TIMEOUT

UPS tried to start PFC system but start is delayed or not started.

F9 DC BUS ????

Before PFC start, DC bus voltage is lower than 50 volts DC. PFC stage is no allowed to start.

F10 BOOSTER SOFT

Booster soft start step could not be completed within 16 seconds

F11 DC BUS ERROR

DC bus voltage is lower than PFC start minimum limit. PFC system can not start.

F12 SHORT CIRC.

There is a short circuit at the output of the UPS. Disconnect loads one by one and try to reset UPS.

F13 WAVEFORM

A63 INV.FAILURE alarm occurred 4 times within 60 minutes. Unstable waveform error.

F14 BATT.SAMPLE?

Battery voltage control signal is lost or signal level is wrong.

F15 4-INV FAIL

Inverter output low or high alarm has occurred 4 times within 1 hour. Inverter output voltage is out of tolerance.

F16 4-OVERCURRE.

Overcurrent has been sensed in UPS 4 times within 1 hour.

F17 MIS-FUNCTION

Maintenance bypass switch is suddenly turned on without switching to manual bypass first.

F18 ALT.PROTECT.

The inverter sinus waveform alternance is longer than expected.

ADJUST MENU

Adjust menu contains some factory selectable options, settings and adjustments. A service password is required, to access the ADJUST MENU. please refer to your local distributor for changing your options.

NOTE : adjust menu is only for service purpose. the wrong usage of this menu can cause damage to UPS.

The following options are selectable from adjust menu :

SPLIT BYP:ON /OFF (Split bypass : on/off)

OPTION	DESCRIPTION
ON	Bypass voltage measurement enabled in measures menu. (BYP.: 230V 50.0Hz)
OFF	Bypass voltage measurement disabled in measures menu.

Split bypass input is the secondary AC input to the UPS. This input is used for transferring the load to bypass. As a default, there is no split bypass input on a standard CL110D series UPS. But during production in the factory, it is possible to install a separate split bypass input to the UPS. The voltage and frequency measurement system is ready and the measurement inputs are shorted to the already available AC input of the UPS. If OFF option is selected bypass voltage and frequency measurement menu item will be cleared from measures menu. If ON option is selected, separate bypass measurements will be shown in measures menu.

REPO INPUT:NO/NC contact (function of the Remote emergency power off input)

OPTION	DESCRIPTION
NO	If REPO input terminals are shorted UPS applies emergency stop
NC	If REPO input terminals are opened UPS applies emergency stop

This selection will be applied after the next power on.

IP.HIGH:BATT /MESSAGE (During mains high alarm operate from batteries or not selection)

OPTION	DESCRIPTION
BATT	During A65 mains high alarm, UPS starts operating from batteries (for protection)
MESSAGE	During A65 mains high alarm, UPS shows only message

In some cases, if the mains input voltage is high (adjustable level), it is better to operate on batteries to prevent any possible damage to the UPS.. But this selection can cause battery discharge if the mains input voltage is continuously high. This function is selectable from adjust menu.

Optional dry contact AUX relays function selection from ADJUST MENU

Two auxiliary relays are available with selectable functions from the adjust menu. The selectable functions are as follows:

Message	Function
RLX:COMMON ALARM	Relay activates on any alarm
RLX:BT.OUT.TOLER	Relay activates if battery voltage is out of tolerance
RLX:OP.OUT.TOLER	Relay activates if output voltage is out of tolerance
RLX:IP.OUT.TOLER	Relay activates if input voltage is out of tolerance
RLX:BYPASS	Relay activates if load is transferred to bypass
RLX:MAINS OK	Relay activates if input voltage is restored
RLX:OVERLOAD	Relay activates if load is greater than 100%
RLX:BATT TEST	Relay activates if battery test is being performed
RLX:OVERTEMP.	Relay activates if cabinet inside temperature is high
RLX:BATT.FUSE	Relay activates if battery fuse is off or blown
RLX:BATT.BAD	Relay activates if battery test fails
RLX:BOOST CHARGE	Relay activates if boost charge is active
RLX:OUTPUT OFF	Relay activates if the output voltage is zero
RLX:INV.FAILURE	Relay activates if inverter failure alarm occurs
RLX:SHUTDOWN	Relay activates if shutdown is applied
RLX:FAULT	Relay activates if any fault occurs

Some other features in adjust menu:

Function	
Mains voltage low alarm level	Adjustable
Mains voltage OK level	Adjustable
Mains voltage high alarm level	Adjustable
Bypass input voltage high warning level	Adjustable
Bypass input voltage low warning level	Adjustable
Battery voltage high alarm level	Adjustable
Battery voltage low warning level	Adjustable
Battery voltage shutdown level	Adjustable
Battery test failed voltage level	Adjustable
Cabinet temperature high alarm level	Adjustable
Output voltage high alarm level	Adjustable
Output voltage low alarm level	Adjustable
Battery charge current	Adjustable
Battery quantity selection	Adjustable
Frequency synchron band	Adjustable
Boost charge time	Adjustable
Voltage range selection	220-230-240 volts AC selectable

V. COMMUNICATION INTERFACE AND REMOTE MANAGEMENT

The following information contains standard communication interface for CL100 series UPS. Additional RS485 interface for long distance communication is available as an option.
The following communication interfaces are available for UPS units

<i>Possible connections to UPS unit</i>	
RS232	Serial communication (Standard)
RS485	Available (Optional)
DRY CONTACTS	Dry contact outputs for some major events.
SNMP connection	Available (Optional)
Modbus connection	Over TCP/IP or over RS485 available (optional)

RS232 hardware	
Baud rate	2400 baud
Connection	3 wire (RX,TX,GND)
Bits	8 bits
Parity	none
Flow	none
Stop bit	1

RS232 CONNECTION TO PC

To connect UPS to any PC from RS232 use CC05 cable for connection. TMON software must be run on PC.



Notes

- CC05 cable is not a standard RS232 cable ,PC side is standard RS232 pins but the UPS side pin functions are different from a standard RS232 cable.
- Maximum cable length of the RS232 interface is 25 meters.

RS232 Pinouts

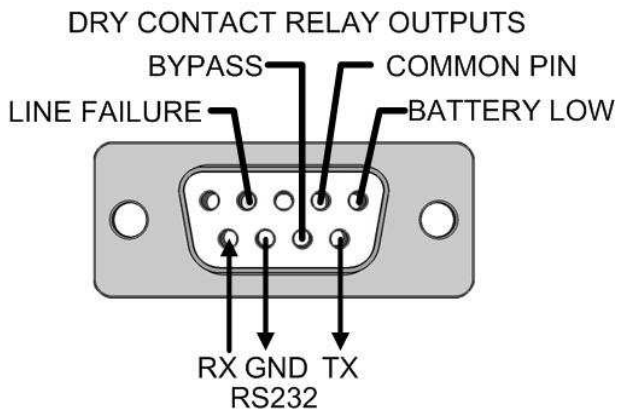

RS232 security

The UPS serial port is interactive with PC computer so the PC can send any command to UPS , in this case unauthorized users can change parameters and send unwanted commands to UPS. To prevent unauthorized access to UPS from serial port security is provided.

For UPS commands **REMOTE : ON/OFF** option determines that the UPS will accept the RS232 commands or not. If off option is selected, the incoming commands from RS232 will be cancelled.

For adjustment parameters you must type the service password from front panel, otherwise any adjustment and option selection parameter will be refused.

Optional SNMP adaptor

The internal and external type adaptors are available for CL110D series UPS .

External SNMP adaptor

If external type data adaptor is used from options menu select **DATA:RS232** option.

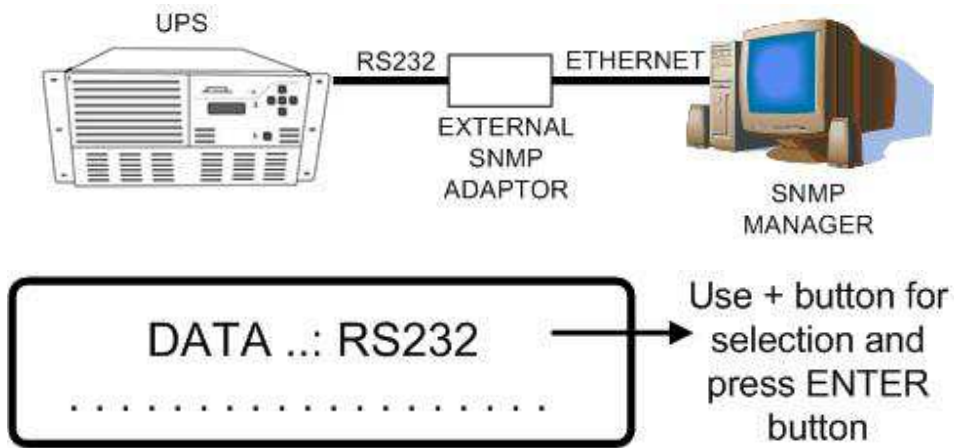

Internal SNMP adaptor

If internal type data adaptor is used from options menu select **DATA:ADAPTOR** option.

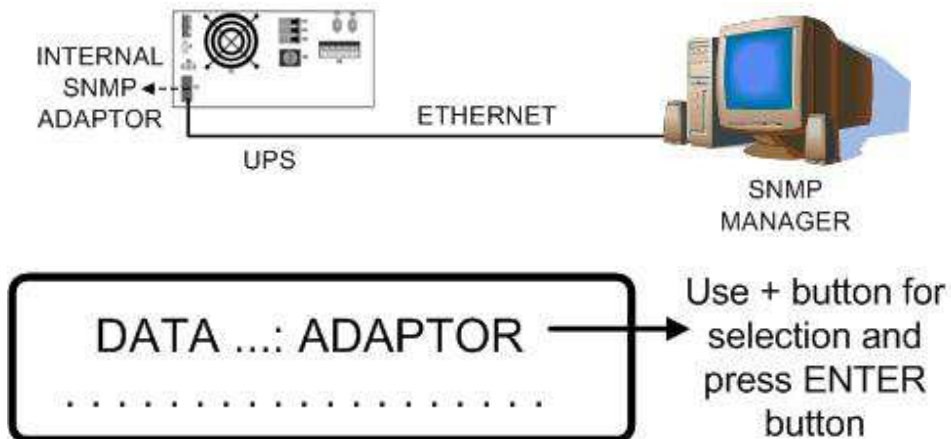

VI. TECHNICAL SPECIFICATIONS

MODEL	CL110D
Output (VA)	10000
Output (KW)	7000
Output Power Factor	0.7
INPUT	
Number of Phases	1 phase + neutral
Input Voltage	220/230/240 VAC (3 wire)
Input Voltage Range (without switching to battery power)	170-275V adjustable
Input Power Factor (PF)	>0.99 at full load
Input THDI	<5% at full load
Input Frequency	50 Hz nominal
Input frequency tolerance	40-65 Hz
By-pass Voltage	220/230/240 VAC, +/-10% (adjustable)
By-pass Frequency	50 Hz
By-pass Frequency Tolerance (for synchronization)	Adjustable between +/- 1.0 and 3.0 Hz
RFI Level	EN62040
Split By-pass Connection	OPTIONAL
Input power connections	Hardwired from the rear
Maintenance bypass switch	OPTIONAL
OUTPUT	
Number of phases	1 phase + neutral + earth (3 wire)
Output Voltage	220/230/240 VAC (3 wire) user selectable
Output Voltage Tolerance	+/- 1%
Output Frequency	50 Hz
Output Frequency Tolerance (line synchronous)	Adjustable between +/-1.0 and 3.0 Hz
Output Frequency Tolerance (free running)	0.01%
Load Crest Factor	3:1
Output Voltage THD	<3%
Overload	Less than 100% continuous 100%-125% for 10 minutes (adjustable) 126%-150% for 1 minute (adjustable)
Output connections	Hardwired+2Xiec sockets on the rear side

BATTERIES	
Total number of battery blocks	20 nominal (battery number selectable)
Internal batteries	20x12V/7Ah
Float Charge Voltage (adjustable)	272 V (for 20x12V batteries at 25 C)
End of Discharge Voltage (adjustable)	192 V (for 20x12V batteries)
Boost Charge	Available
Boost charge voltage (adjustable)	288 V (for 20x12V batteries)
Battery Test	Available (automatic or manual)
Max. recharging current (adjustable)	3.0 A DC (independent of the o/p load)
Average battery high protection	standard
Cold start from batteries	standard
Battery temperature compansiation	standard
INTERFACE	
RS 232 comm. Port	Standard
RS 485 comm. Port	OPTIONAL
Remote Monitoring Panel	OPTIONAL
SNMP Adaptor	OPTIONAL
Modbus Adaptor	OPTIONAL
Alarm Relay Contacts	3x standard (+ 2xprogrammable relay optional)
Alarm relay NO/NC selection	standard
REPO Input	Standard (NO/NC selectable)
Remote monitoring panel	OPTIONAL
ENVIRONMENT	
Operating Temperature	0-40 C
Operating Humidity	<90% non-condensing
Max. Installation altitude	2000m at nominal power
Acoustic Noise	<50 dB
Dimensions (WxDxH) (mm)	215 x 775 x 585 mm
Protection Class	IP20
Weight (Without Batteries)	36 kgs
Weight (With internal batteries)	80 kgs (with 20x12V/7Ah batteries)

AGKK9040 12/2009