



MODULAR UPS

MTW 25-300 KVA

USER MANUAL

Preface

Manual Usage

This manual introduces the main characteristics, performance, and working principle of the new generation modular intelligent UPS, and provides users with information on installation, use, operation, and maintenance.

Users

Technical Support Engineer
Service Engineer
Authorized Person

Note

Our company provides a full range of technical support and service. Customers can contact our local office or customer service center for help.

The manual will update irregularly, due to the product upgrading or other reasons.

Unless otherwise agreed, the manual is only used as guide for users and any statements or information contained in this manual make no warranty expressed or implied.

Contents

Preface.....	2
Manual Usage.....	2
Users.....	2
Note.....	2
1 Safety Precautions	6
1.1 Safety Information Definition	6
1.2 Warning Label.....	6
1.3 Safety Instruction.....	6
1.5 Debug & Operate.....	7
1.6 Maintenance & Replacement	7
1.7 Battery Safety	8
1.8 Disposal	9
1.9 Note	9
2 Overview	10
2.1 Product Introduction	10
2.2 UPS System Description	10
2.3 Power Module Description	11
2.4 Operation Mode	11
2.4.1 Normal Mode.....	11
2.4.2 Battery Mode.....	12
2.4.3 Bypass Mode	12
2.4.4 Maintenance Mode (Manual Bypass)	13
2.4.5 ECO Mode.....	13
2.4.6 Auto-restart Mode.....	14
2.4.7 Frequency Con-verter Mode	14
2.1 UPS Structure.....	14
3 Installation	18
3.1 Location	18
3.1.1 Installation Environment.....	18
3.1.2 Site Selection	18
3.1.3 Size and Weight	18
3.2 Unloading and Unpacking	21
3.2.1 Moving and Unpacking of the Cabinet.....	21
3.3 Positioning	23
3.3.1 Positioning Cabinet	23
3.3.2 Rack Mounting	25
3.4 Battery.....	27
3.5 Cable Entry	28
3.6 Switch between Single Input and Double Input of Cabinet.....	29

3.7	Power Cables	30
	3.7.1 Specifications	30
	3.7.2 Specifications for Power Cables Terminal	31
	3.7.3 Circuit Breaker	31
	3.7.4 Connecting Power Cables	32
3.8	Control and Communication Cables.....	34
	3.8.1 Dry Contact Interface	35
	3.8.2 Communication Interface	41
4	UPS Control LCD Panel	42
4.1	UPS LCD Panel	42
	4.1.1 LED Indicator	42
	4.1.2 Control and Operation Keys.....	43
	4.1.3 LCD Touch Screen	43
4.2	Main Menu	45
	4.2.1 User Login	45
	4.2.2 Cabinet Menu.....	45
	4.2.3 Module menu	47
	4.2.4 Set Menu	48
	4.2.5 Log Menu	50
	4.2.6 Control Menu.....	59
	4.2.7 Scope Menu	62
5	Operations	63
5.1	UPS Start-up.....	63
	5.1.1 Startup in Normal Mode	63
	5.1.2 Start from Battery	63
5.2	UPS Shut down	65
5.3	Procedure for Switching between Operation Modes.....	65
	5.3.1 Switching the UPS from Normal Mode into Battery Mode.....	65
	5.3.2 Switching the UPS from Normal Mode into Bypass Mode	65
	5.3.3 Switching the UPS into Normal Mode from Bypass Mode	66
	5.3.4 Switching the UPS into Maintenance Bypass Mode from Normal Mode ..	66
	5.3.5 Switching the UPS into Normal Mode from Maintenance Bypass Mode ..	67
5.4	Battery Maintenance.....	67
5.5	EPO	68
5.6	Installation of Parallel Operation System	69
6	Maintenance	71
6.1	Precautions.....	71
6.2	Instruction for Maintaining Power Module	71
6.3	Instruction for Maintaining the Monitor & Bypass Unit	72
6.4	Battery Maintenance.....	72

7	Product Specifications	74
7.1	Applicable Standards.....	74
7.2	Environmental Characteristics.....	74
7.3	Mechanical Characteristics	75
7.4	Electrical Characteristics	75
	7.4.1 Electrical Characteristics (Input Rectifier).....	75
	7.4.2 Electrical Characteristics (Intermediate DC Link).....	75
	7.4.3 Electrical Characteristics (Inverter Output).....	76
	7.4.4 Electrical Characteristics (Bypass Mains Input)	77
7.5	Efficiency.....	77
7.6	Display and Interface.....	78

1 Safety Precautions

This manual contains information concerning the installation and operation of modular UPS. Please carefully read this manual prior to installation.

The modular UPS cannot be put into operation until it is commissioned by engineers approved by the manufacturer (or its agent). Not doing so could result in personnel safety risk, equipment malfunction and invalidation of warranty.

1.1 Safety Information Definition

Danger: Serious human injury or even death may be caused, if this requirement is ignored.



Warning: Human injury or equipment damage may be caused if this requirement is ignored.

Attention: Equipment damage, loss of data or poor performance may be caused, if this requirement is ignored.

Commissioning Engineer: The engineer who installs or operates the equipment should be well trained in electricity and safety, and familiar with the operation, debug, and maintenance of the equipment.



1.2 Warning Label

The warning label indicates the possibility of human injury or equipment damage and advised the proper step to avoid the danger. In this manual, there are three types of warning labels as below.



Labels	Description
 DANGER	Serious human injury or even death may be caused, if this requirement is ignored.
 WARNING	Human injury or equipment damage may be caused, if this requirement is ignored.
 CAUTION	Equipment damage, loss of data or poor performance may be caused if this requirement is ignored.

1.3 Safety Instruction



 DANGER	<ul style="list-style-type: none">■ Performed only by commissioning engineers.■ This UPS is designed for commercial and industrial applications only and is not intended for any use in life-support devices or system.
---	--

 WARNING	<ul style="list-style-type: none"> Read all the warning labels carefully before operation and follow the instructions.
	<ul style="list-style-type: none"> When the system is running, do not touch the surface with this label, to avoid any hurt of scald.
	<ul style="list-style-type: none"> ESD sensitive components inside the UPS, anti-ESD measure should be taken before handling.

1.4 Move & Installation

 DANGER	<ul style="list-style-type: none"> Keep the equipment away from heat source or air outlets. In case of fire, use dry powder extinguisher only, any liquid extinguisher can result in electric shock.
 WARNING	<ul style="list-style-type: none"> Don't start the system if any damage or abnormal parts are found. Contacting the UPS with wet material or hands may be subject to electric shock.
 CAUTION	<ul style="list-style-type: none"> Use proper facilities to handle and install UPS. Shielding shoes, protective clothes and other protective facilities are necessary to avoid injury. During positioning, keep the UPS way from shock or vibration. Install the UPS in proper environment, more detail in section 2.3.

1.5 Debug & Operate

 DANGER	<ul style="list-style-type: none"> Make sure the grounding cable is well connected before connecting the power cables, the grounding cable and neutral cable must be in accordance with the local and national codes practice. Before moving or re-connecting the cables, make sure to cut off all the input power sources, and wait for at least 10 minutes for internal discharge. Use a multi-meter to measure the voltage on terminals and ensure the voltage is lower than 36V before operation.
 WARNING	<ul style="list-style-type: none"> The earth leakage current of load will be carried by RCCB OR RCD. Initial check and inspection should be performed after a long time of storing of UPS.

1.6 Maintenance & Replacement

 DANGER	<ul style="list-style-type: none"> All the equipment maintenance and servicing procedures involving internal access need special tools and should be carried out only by trained personnel. The components that can be accessed by opening the protective cover with tools cannot be maintenance by the user.
---	--

	<ul style="list-style-type: none"> ■ This UPS full complies with "IEC62040-1-1-General and safety requirements for use in operator access area UPS". Dangerous voltages are present within the battery box. However, the risk of contact with these high voltages is minimized for non-service personnel. Since the component with dangerous voltage can only be touched by opening the protective cover with a tool, the possibility of touching high voltage component is minimized. No risk exists to any personnel when operating the equipment in a normal manner, following the recommended operating procedures in this manual.
--	---

1.7 Battery Safety

 <p>DANGER</p>	<ul style="list-style-type: none"> ■ All the battery maintenance and servicing procedures involving internal access need special tools or keys and should be carried out only by trained personnel. ■ When connected, the battery terminal voltage will exceed 400Vdc and is potentially lethal. ■ Battery manufacturers supply details of the necessary precautions to be observed when working on, or in the vicinity of a large bank of battery cells. These precautions should be always followed implicitly. Particular attention should be paid to the recommendations concerning local environmental conditions and the provision of protective clothing, first aid and fire-fighting facilities. ■ Ambient temperature is a major factor in determining the battery capacity and life. The nominal operating temperature of battery is 20°C. Operating above this temperature will reduce the battery life. Periodically change the battery according to the battery user manuals to ensure the back-up time of UPS. ■ Replace the batteries only with the same type and the same number, or it may cause an explosion or poor performance. ■ When connecting the battery, follow the precautions for high-voltage operation before accepting and using the battery, checking the appearance of the batteries. If the package is damaged, or the battery terminal is dirty, corroded or rusted or the shell is broken, deformed or has leakage, replace it with new product. Otherwise, battery capacity reduction, electric leakage or fire may be caused. ■ Before operating the battery, remove the finger ring, watch, necklace, bracelet and any other metal jewelry. ■ Wear rubber gloves. ■ Eye protection should be worn to prevent injury from accidental electrical arcs. ■ Only use tools (e.g. wrench) with insulated handles. ■ The batteries are very heavy. Please handle and lift the battery with proper method to prevent any human injury or damage to the battery terminal. ■ Don't decompose, modify or damage the battery. Otherwise, battery short circuit, leakage or even human injury may be caused. ■ The battery contains sulfuric acid. In normal operation, all the sulfuric acid is attached to the separation board and plate in the battery. However, when the battery shell is broken, the
--	---

	<p>acid will leak from the battery. Therefore, be sure to wear a pair of protective glasses, rubber gloves and skirt when operating the battery. Otherwise, you may become blind if acid enters your eyes, and your skin may be damaged by the acid.</p> <ul style="list-style-type: none"> ■ At the end of battery life, the battery may have internal short circuit, drain of electrolytic and erosion of positive/negative plates. If this condition continues, the battery may have temperature out of control, swell or leak. Be sure to replace the battery before these phenomena happen. ■ If a battery leaks electrolyte, or is otherwise physically damaged, it must be replaced, stored in a container resistant to sulfuric acid and disposed of in accordance with local regulations. ■ If electrolyte encounters the skin, the affected area should be washed immediately with water.
--	--

1.8 Disposal

 WARNING	<ul style="list-style-type: none"> ■ Dispose of used battery according to the local instructions.
--	--

1.9 Note

 Note	<ul style="list-style-type: none"> ■ Represents a supplementary explanation or emphasis to the main text.
---	--

2 Overview

2.1 Product Introduction

Intelligent modular UPS series products using on-line double conversion design, based on the DSP full digital control, provide stable, uninterrupted power supply, can eliminate the mains surge, instantaneous high voltage, instantaneous low voltage, wire noise and frequency offset "power pollution", to provide customers with high efficiency, high power density of power supply guarantee.

2.2 UPS System Description

Intelligent modular UPS is mainly composed of conversion main circuit, bypass static switch, external battery pack, etc., and 4 modules and 6 modules cabinet including manual bypass switch. The UPS system is shown in Figure 2-1.

The conversion main circuit is parallel connected by multiple UPS power modules, mainly including the AC-DC-AC structure composed of the rectifier (REC) inverter (INV). The bypass static switch is composed of reverse parallel SCR, and the mains can supply power directly to the load through the bypass static switch. Manual bypass switch is a isolation switch. When repairing the UPS, manual bypass switch can be used to ensure uninterrupted load power supply. The external battery pack supplies power to the load through the inverter when the mains power is cut off.

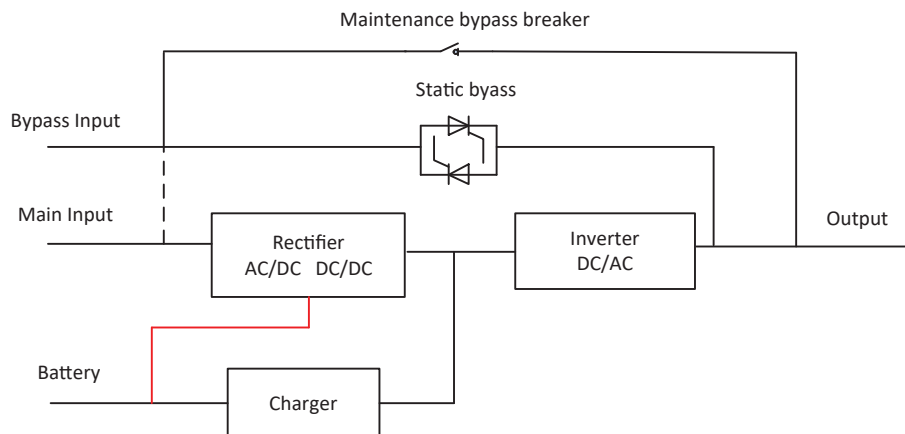

Figure 2-1 UPS schematic diagram

2.3 Power Module Description

The power module structure is shown as Figure 2-2. The power module contains a rectifier, an inverter, and one DC charger.

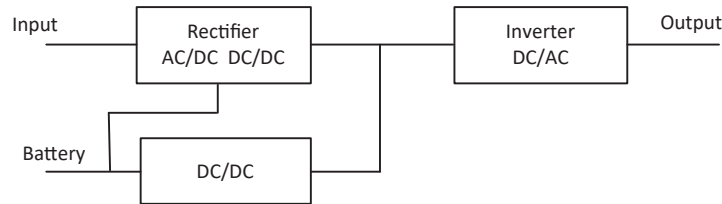

Figure 2-2 Power module schematic diagram

2.4 Operation Mode

The modular UPS is an on-line, double-conversion UPS that permits operation in the following modes:

- Normal mode
- Battery mode
- Bypass mode
- Maintenance mode (manual bypass)
- ECO mode
- Auto-restart Mode
- Frequency Converter mode

2.4.1 Normal Mode

The UPS turns the AC input into DC voltage (AC / DC) through the rectifier, and the DC voltage boosts to the BUS voltage. When the system is connected to the external battery, part of the charger charges the battery (DC / DC), and the other part changes the inverter to the DC output (DC / AC) to provide high quality AC power for the load. The working principle of the normal mode is shown in Figure 2-3.

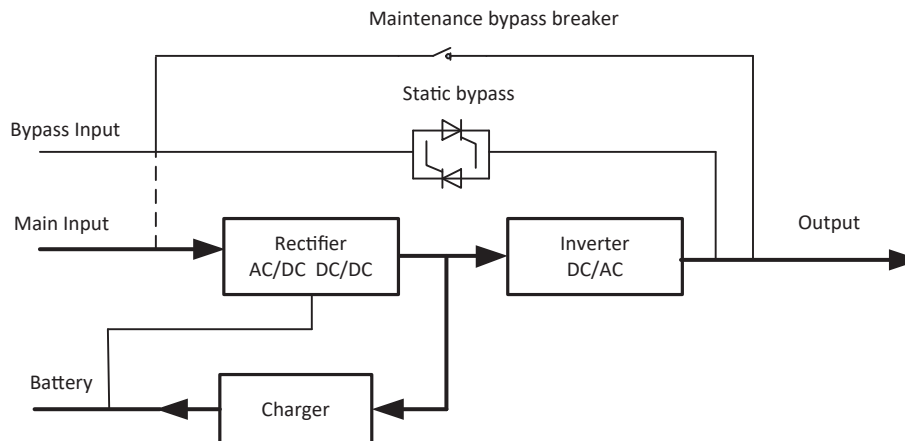

Figure 2-3 Normal mode schematic diagram

2.4.2 Battery Mode

Upon failure of the AC mains input power, the inverters of power modules will obtain power from the batteries, and supply AC power to the critical AC load. There is no interruption to the critical load. After restoration of the AC mains input power, UPS will transfer automatically to normal mode. Battery schematic diagram as shown below Figure 2-4.

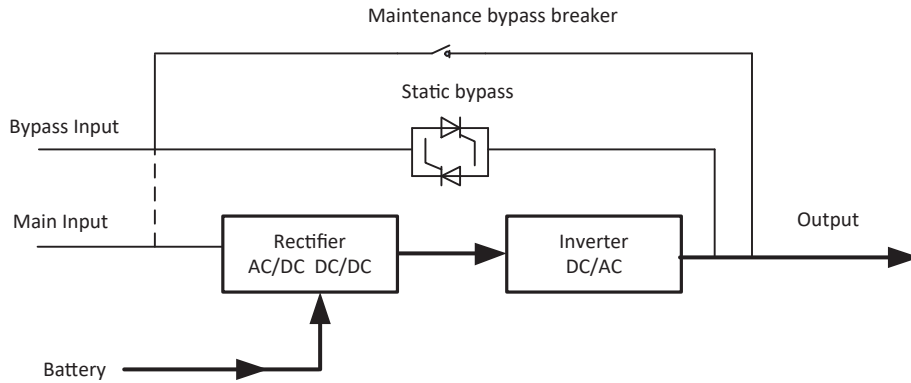

Figure 2-4 Battery mode schematic diagram

Note: With the function of "Battery Cold Start", the UPS could start without utility.

2.4.3 Bypass Mode

After the system is powered on, when the inverter is not turned on or the inverter is artificially turned off, the load is powered by the bypass. In the normal mode, if the UPS monitoring unit detects the power module over temperature, overload or other shutdown failure of the inverter, the system will automatically switch to the bypass. In this condition, the mains directly supplies power to the load through the bypass static switch. In the bypass mode, the load power supply quality is not protected by UPS, and it is susceptible to power failure, voltage waveform or abnormal frequency conditions. Bypass mode schematic diagram is shown in Figure 2-5.

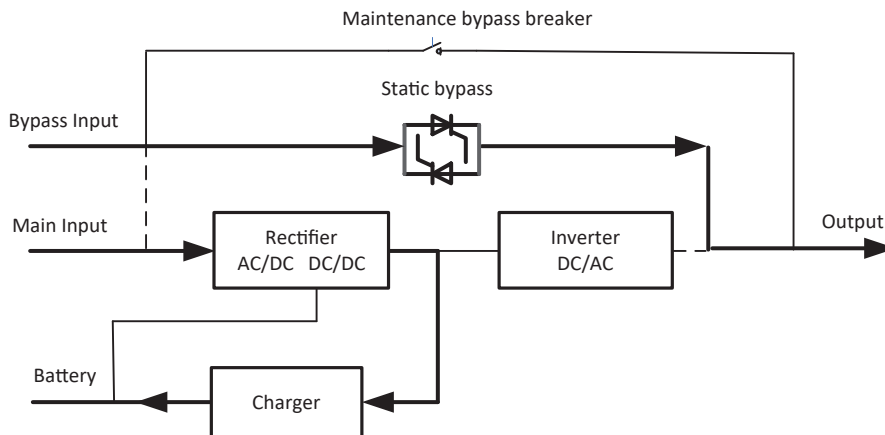

Figure 2-5 Bypass mode schematic diagram

2.4.4 Maintenance Mode (Manual Bypass)

When repairing the UPS system and battery or repairing the equipment failure, manually close the manual bypass switch, and the load is directly supplied by the mains power through the manual bypass to realize the emergency power supply to the load. Manual bypass mode schematic diagram is shown in Figure 2-6.

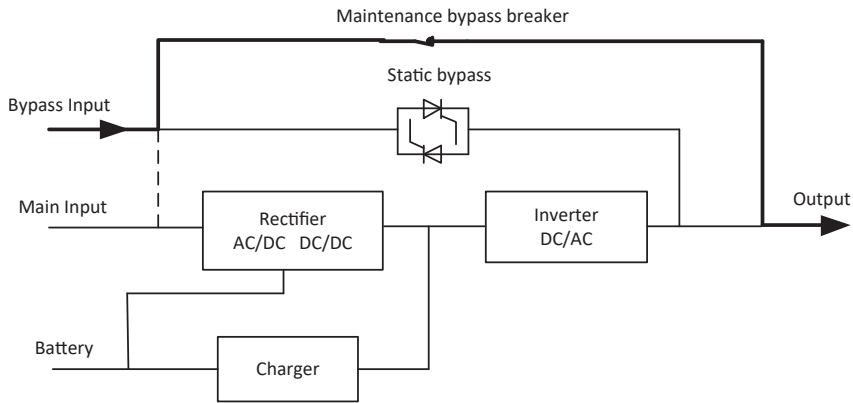

Figure 2-6 Maintenance mode schematic diagram



DANGER

During Maintenance mode, dangerous voltages are present on the terminal of input, output and neutral, even with all the modules and the LCD turned off.

2.4.5 ECO Mode

To improve system efficiency, UPS system works in Bypass Mode at normal time, and the inverter is standby, when the utility from the bypass fails, the UPS will transfer to Battery Mode and the inverter powers the load. ECO mode schematic diagram is shown in Figure 2-7.

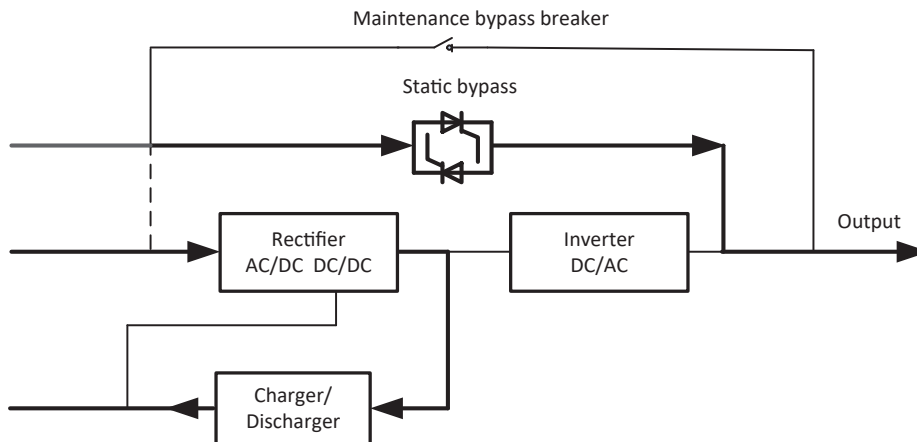

Figure 2-7 ECO mode schematic diagram



Note

There is a short interruption time (less than 10ms) when transferring from ECO mode to battery mode, it must be sure that the interruption has no effect on loads.

2.4.6 Auto-restart Mode

UPS provides automatic power-on function, that is, the mains power outage time is too long, the battery discharge to the EOD voltage causes the inverter to shut down. If the mains power recovery, UPS will automatically start UPS. **The mode and the delay time are programmed by the commissioning engineer.**

2.4.7 Frequency Converter Mode

By setting the UPS to "Frequency Converter Mode", the UPS could present a stable output of fixed frequency (50 or 60HZ), and the bypass static switch is not available. The input frequency range ranged from 40 Hz to 70 Hz. In this mode, the static bypass is invalid, and the battery is optional, as to determine whether to choose the battery according to whether to operate in battery mode.

2.1 UPS Structure

2.5.1 UPS Configuration

The UPS configurations are provided in Table 2-1.

Table 2-1 UPS Configuration

Item	Component	Quantity/PCS	Remark
4-slot cabinet	Manual Bypass breaker	1	standard
6-slot cabinet	Bypass & Monitoring unit	1	standard
10-slot cabinet			
25KVA power module	Power module	1~10	/
30KVA power module	Power module	1~10	/

2.5.2 UPS System Outlook

The UPS front outlooks are shown as figure 2-8.

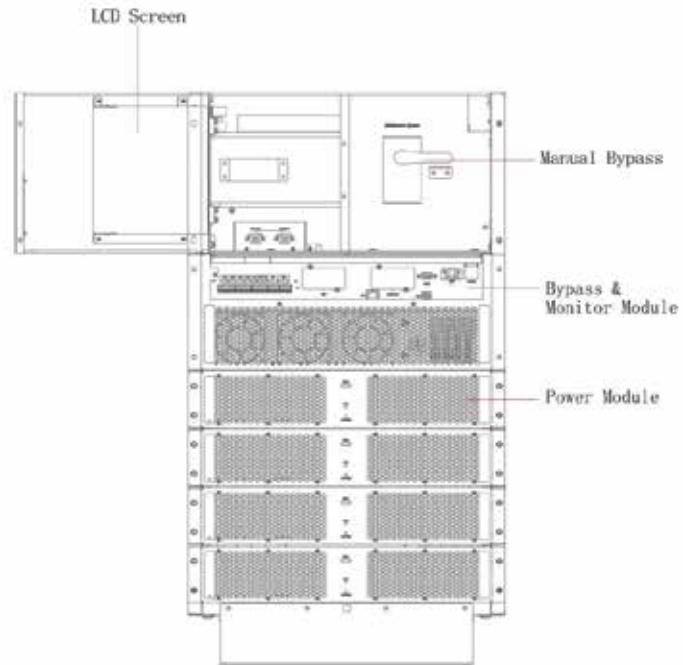

(a) The front view of 4-slot cabinet

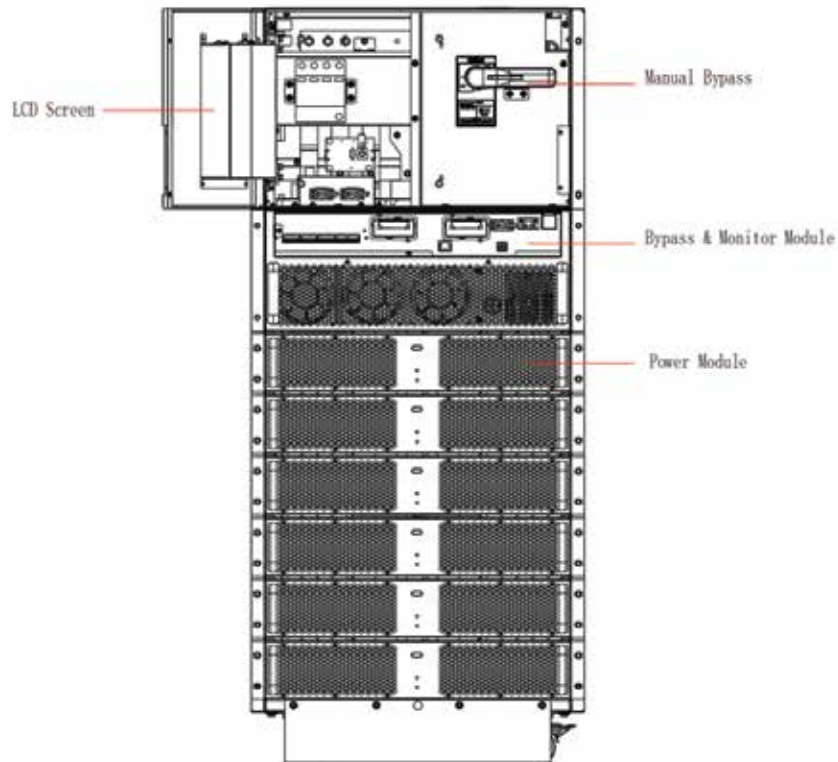

(b) The front view of 6-slot cabinet

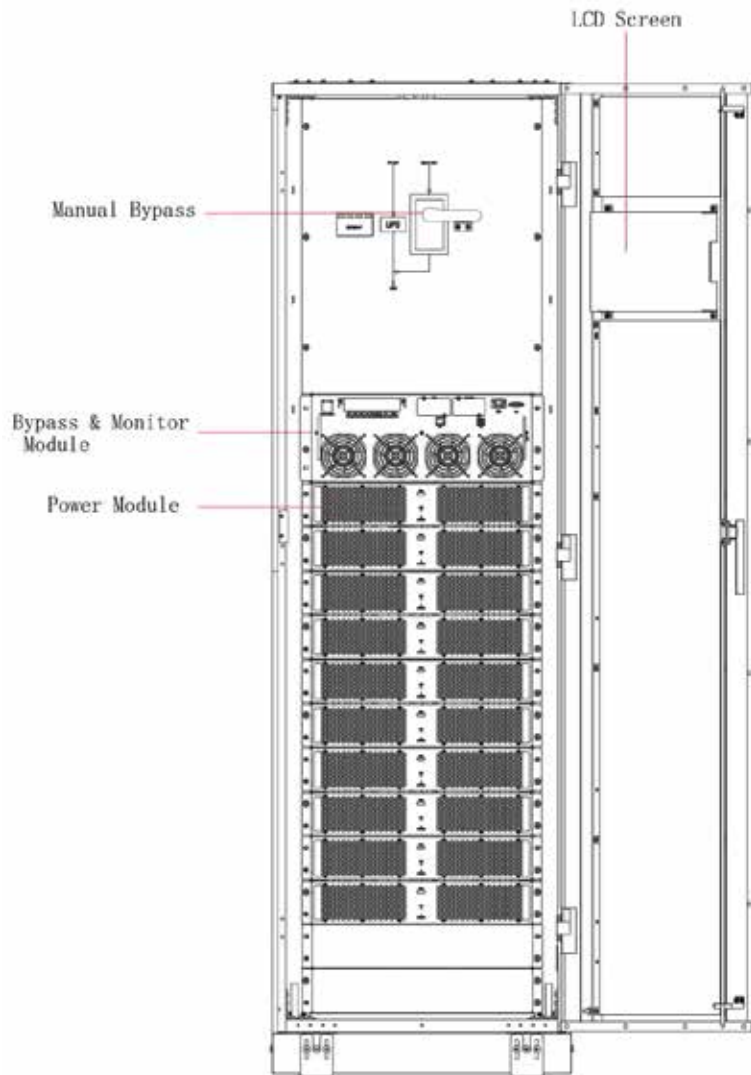

(c) The front view of 10-slot cabinet
Figure 2-8 System Front view

The UPS back outlooks are shown as figure 2-9.

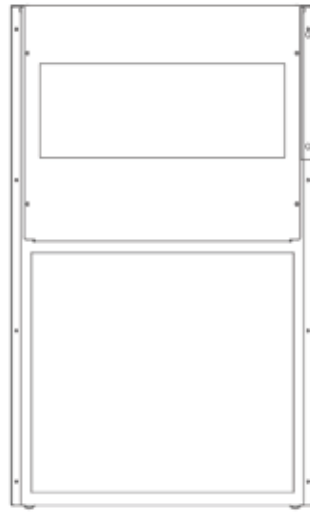

(a) The back view of 4-slot & 6-slot cabinet

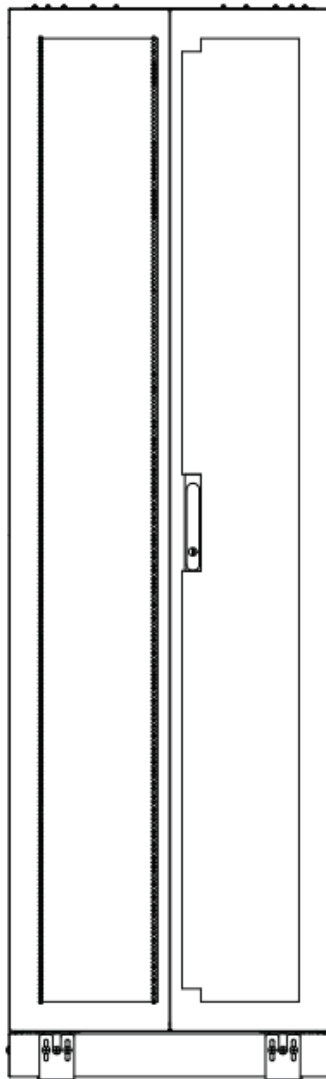

(b) The back view of 10-slot cabinet

Figure 2-9 System back view

3 Installation

3.1 Location

As each site has its requirements, the installation instructions in this section are as a guide for the general procedures and practices that should be observed by the installing engineer.

3.1.1 Installation Environment

The UPS is intended for indoor installation and uses forced convection cooling by internal fans. Please make sure there is enough space for the UPS ventilation and cooling.

Keep the UPS far away from water, heat and inflammable and explosive corrosive material. Avoid installing the UPS in the environment with direct sunlight, dust, volatile gases, corrosive material and high salinity.

Avoid installing the UPS in the environment with conductive dirt.

The operating environment temperature for batteries is 20°C-25°C. Operating above 25°C will reduce the battery life, and operation below 20°C will reduce the battery capacity.

The battery will generate a little amount of hydrogen and oxygen at the end of charging; ensure the fresh air volume of the battery installation environment must meet EN50272-2001 requirements.

When external batteries are used, the battery circuit breakers (or fuses) must be mounted as close as possible to the batteries, and the connecting cables should be as short as possible.

3.1.2 Site Selection

Ensure the ground or installation platform can bear the weight of the UPS cabinet, batteries and battery racks.

No vibration and less than 5-degree inclination horizontally.

The equipment should be stored in a room to protect it against excessive humidity and heat sources.

The battery needs to be stored in a dry and cool place with good ventilation. The most suitable storage temperature is 20°C to 25°C.

3.1.3 Size and Weight

Ensure there is enough space for the placement of UPS. The room reserved for the UPS cabinet is shown in Figure 3-1.

The 4 slot and 6 slot UPS come optionally with a bottom entry cable assembly, with a

depth of 916mm. The UPS depth of 816mm does not include the bottom entry cable assembly.



DANGER

Ensure the following space margin: at least 0.8m before the front door of the cabinet, so as to easily maintain the power module with the front door fully open; at least 0.5m at behind the cabinet for ventilation and cooling; at least 0.5m distance from the top of the cabinet. The space reserved for the cabinet is shown in Figure 3-2.

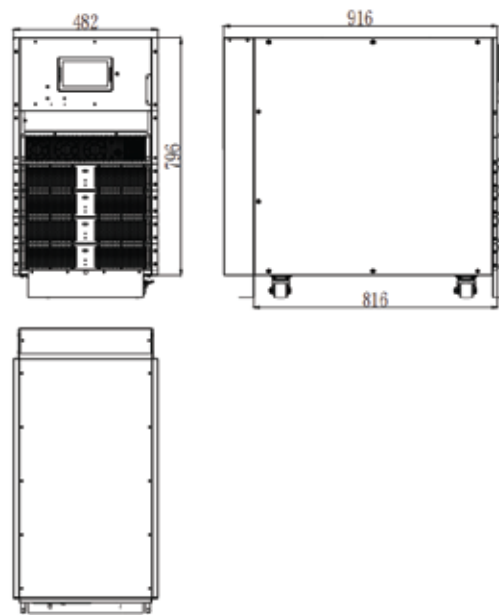

(a) The size diagram of the 4-slot cabinet (Unit:mm)



(b) The size diagram of the 6-slot cabinet (Unit:mm)

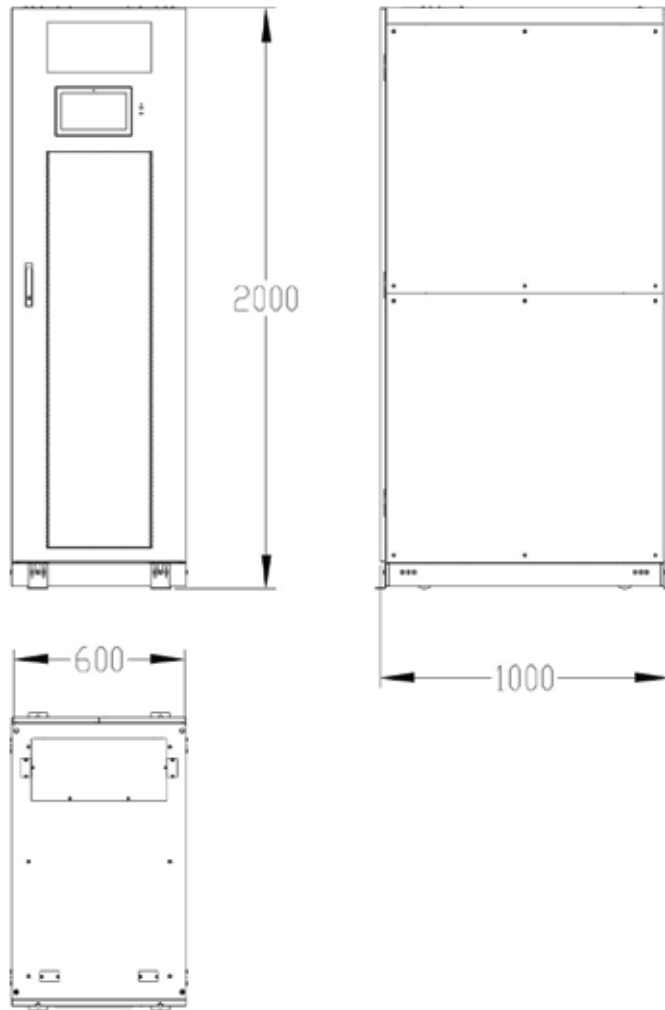

(c) The size diagram of the 6-slot cabinet (Unit:mm)
Figure 3-1 cabinet size diagram (Unit:mm)



Figure 3-2 Space reserved for the cabinet (Unit: mm)

It should be ensured that the ground or installation platform can withstand the weight of UPS cabinets, batteries, and battery racks. The weight of batteries and battery racks is calculated based on actual usage, and the weight of UPS is shown in Table 3-1

Table 3-1 Dimension and Weigh for the cabinet

Configuration	Weight(Kg)
4-slot Cabinet	85
6-slot Cabinet	130
10-slot Cabinet	250
25KVA power module	20
30KVA power module	21

3.2 Unloading and Unpacking

3.2.1 Moving and Unpacking of the Cabinet

The steps to move and unpack the cabinet are as follows:

- 1) Check if any damages to the packing. (If any, please contact the carrier)
- 2) Transport the equipment to the designated site by forklift, as shown in Figure 3-3.

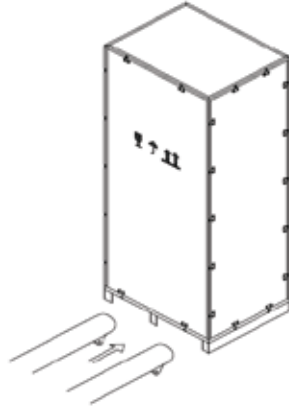

Figure 3-3 Transport to the designated site

- 3) Open the top plate of the steel-edged wooden case with the awl and the hammer, followed by side boards (see Figure 3-4).

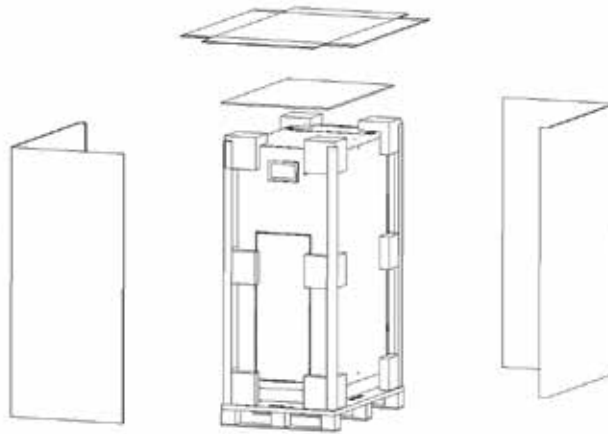

Figure 3-4 disassemble the case

- 4) Remove the protective foam around the cabinet. As show below Figure 3-5.

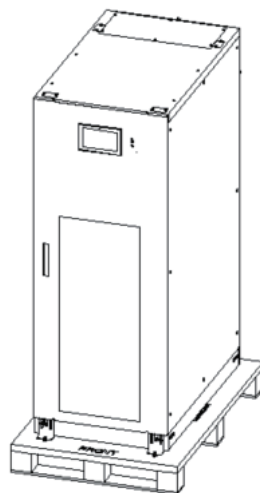

Figure 3-5 remove the protective foam

- 5) Check the UPS, visually examine if there are any damages to UPS during

transportation. If any damages, please contact the carrier. Check the UPS with the list of the goods. If any items are not included in the list, please contact our company or the local office.

- 6) Dismantle the bolts that connect the cabinet and wooden pallet after disassembly.
- 7) Move the cabinet to the installation position.

 **CAUTION**

Be careful while removing to avoid scratching the equipment.

3.3 Positioning

3.3.1 Positioning Cabinet

The UPS cabinet has two way of supporting itself: One is to support itself temporarily by the four wheels at the bottom, making it convenient to adjust the position of the cabinet; The other is by anchor bolts to support the cabinet permanently after adjusting the position of the cabinet. The supporting structure is shown in Figure 3-6.

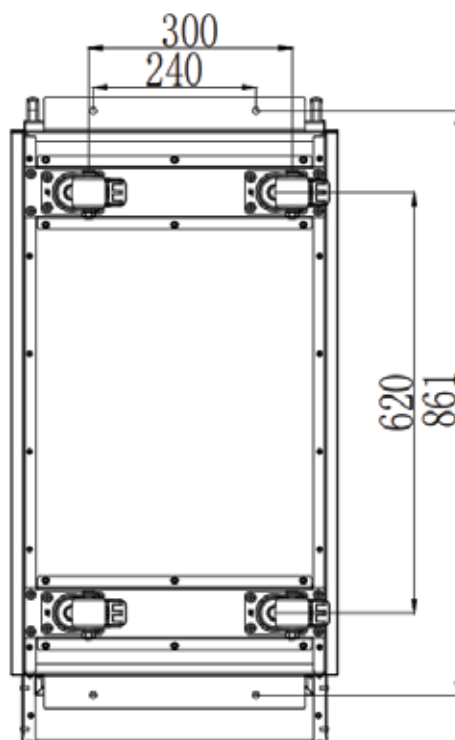

(a) 4-slot cabinet UPS (Bottom View, unit: mm)

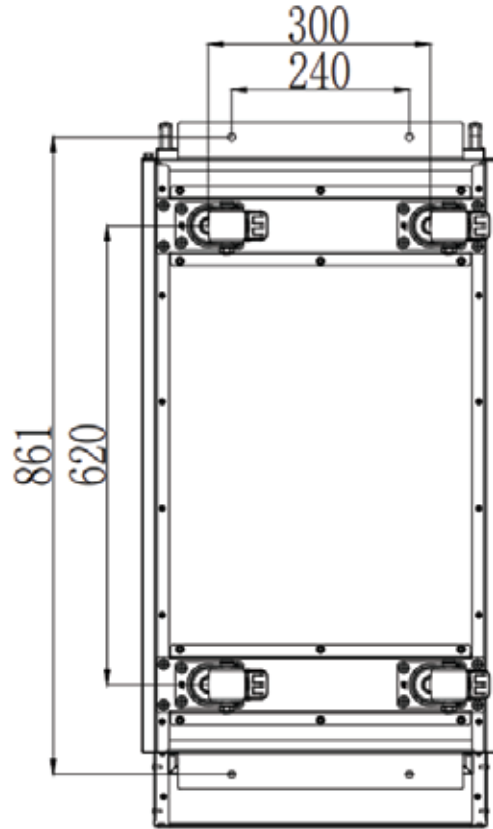

(b) 6-slot cabinet UPS (Bottom View, unit: mm)

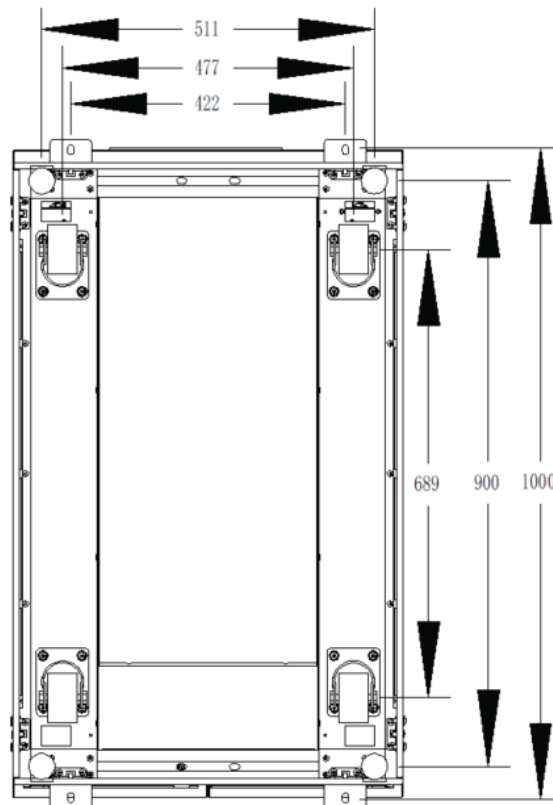

(c) 10-slot cabinet UPS (Bottom View, unit: mm)

Figure 3-6 Supporting structure (Bottom View)

The steps of position the cabinet are as follows:

- 1) Ensure the supporting structure is in good condition and the mounting floor is smooth and strong.
- 2) Retract the anchor bolts by turning them counterclockwise with the wrench, the cabinet is then supported by the four wheels.
- 3) Adjust the cabinet to the right position by the supporting wheels.
- 4) Put down the anchor bolts by turning them clockwise with the wrench, the cabinet is then supported by the four anchor bolts.
- 5) Ensure the four anchor bolts are in the same height and the cabinet is fixed and immovable.

 **CAUTION**

Auxiliary equipment is needed when the mounting floor is not solid enough to support the cabinet, which helps distribute the weight over a larger area. For instance, cover the floor with iron plate or increase the supporting area of the anchor bolts.

3.3.2 Rack Mounting

The 4 module and 6 module cabinets support rack installation to meet the application of micro module room.

The specific process of UPS rack installation is as follows:

1. Remove the cabinet casters.
2. Remove the cabinet side door, lower inlet wire frame and its accessories, as shown in Figure 3-7.

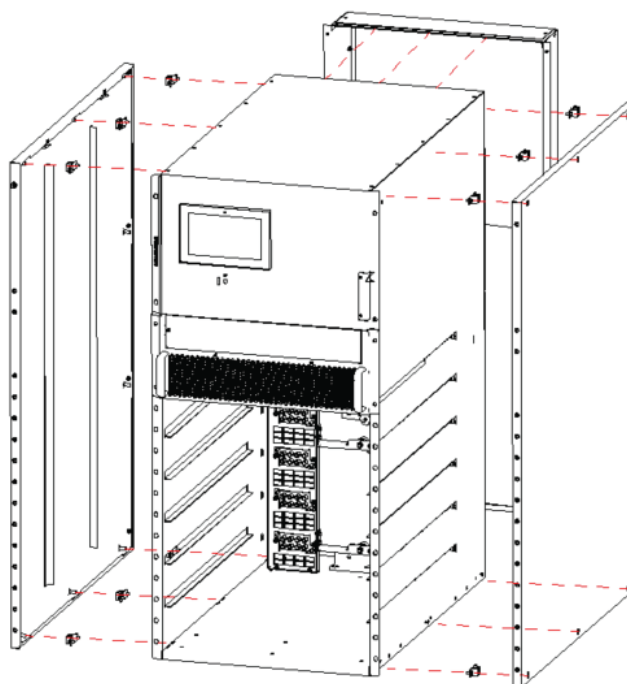

Figure 3-7 Installation schematic diagram

3. The 4-6 slot module cabinet is directly loaded into the server cabinet, placed on the guide rail, and lock the screws of the bypass module and the manual bypass switch panel, as shown in Figure 3-8.

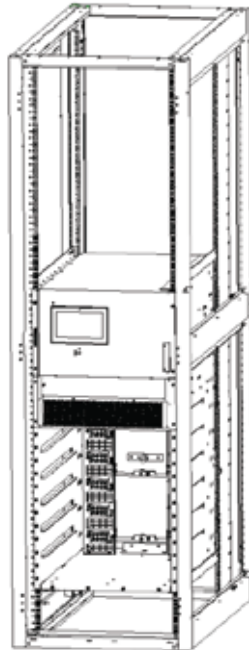

Figure 3-8 Installation schematic diagram

4. Insert the module into the UPS cabinet and lock the module panel screws, as shown in Figure 3-9.

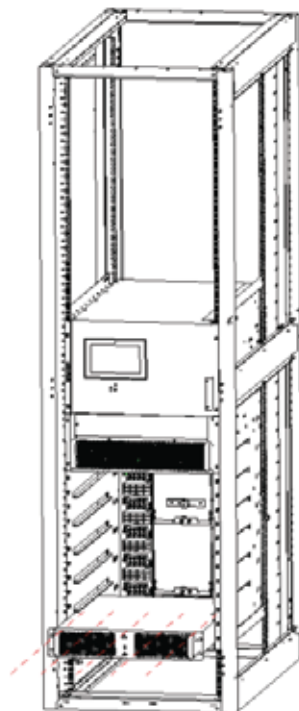

Figure 3-9 Installation schematic diagram

5.Complete installation.

3.4 Battery

Three terminals (positive, neutral, negative) are drawn from the battery group and connected to UPS system. The neutral line is draw from the middle of the batteries in series (See Figure 3-10)

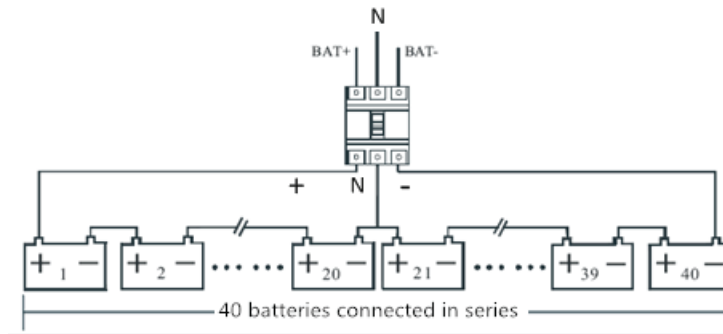

Figure 3-10 Battery string wiring diagram



DANGER

The battery terminal voltage is of more than 400Vdc, please follow the safety instructions to avoid electric shock hazard.

Ensure the positive, negative, neutral electrode is correctly connected from the battery unit terminals to the breaker and from the breaker to the UPS system.

3.5 Cable Entry

The product can support top and bottom entry. The cable entry is shown in Figure 3-11.

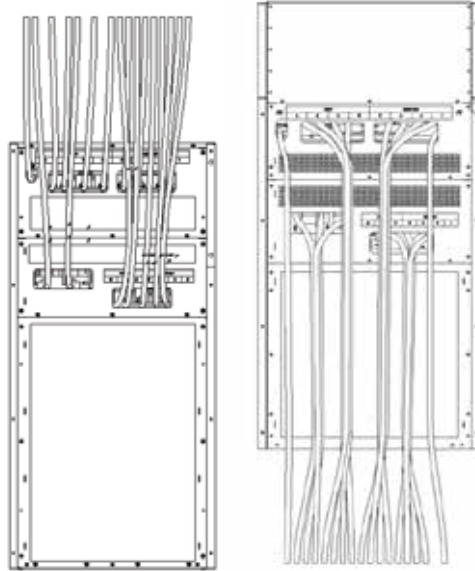

(a) 4-slot & 6-slot cabinet top cables entry diagram

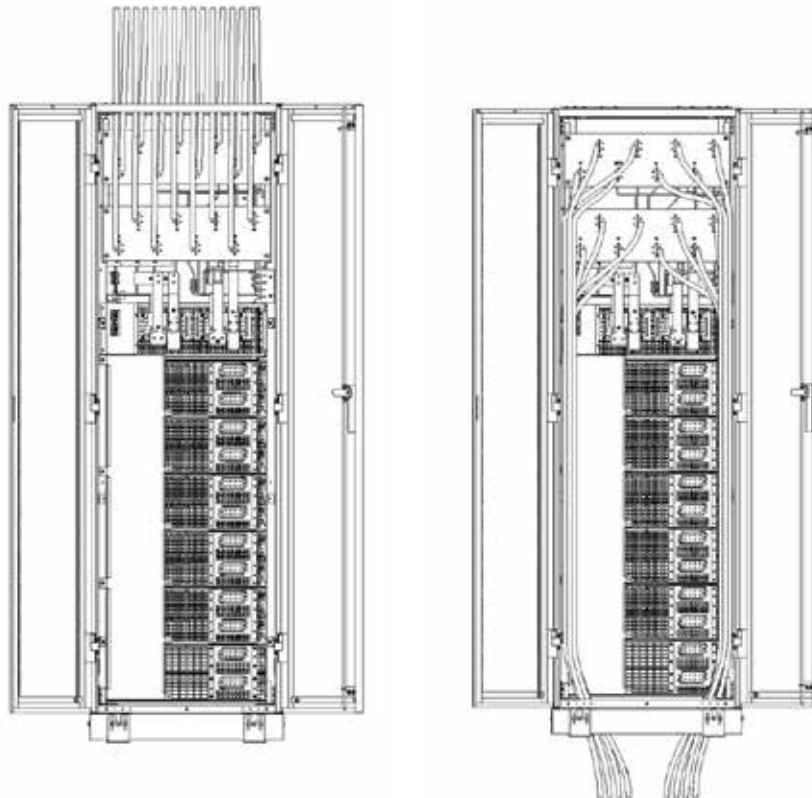

(b) 10-slot cabinet bottom cables entry diagram

Figure 3-11 Cable entry diagram

3.6 Switch between Single Input and Double Input of Cabinet

When the UPS cabinet leaves the factory, it defaults to a double input configuration.

Change dual input to single input, just need to install the main input and the bypass input short connecting copper bar(optional). As Figure 3-12 shows:

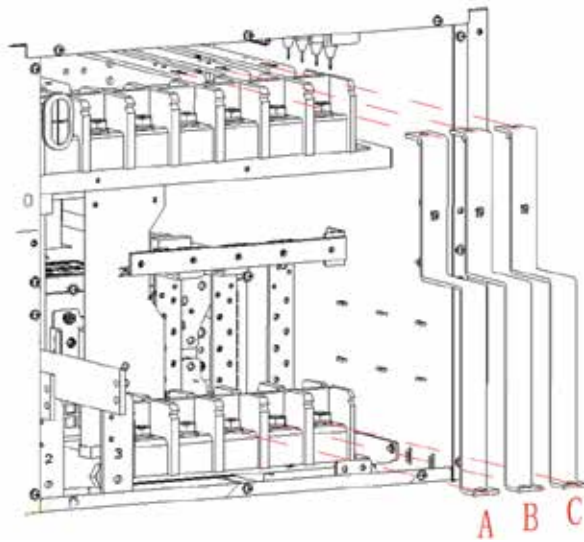

(a) 4-slot & 6-slot cabinet main input and bypass input short connecting copper bar diagram

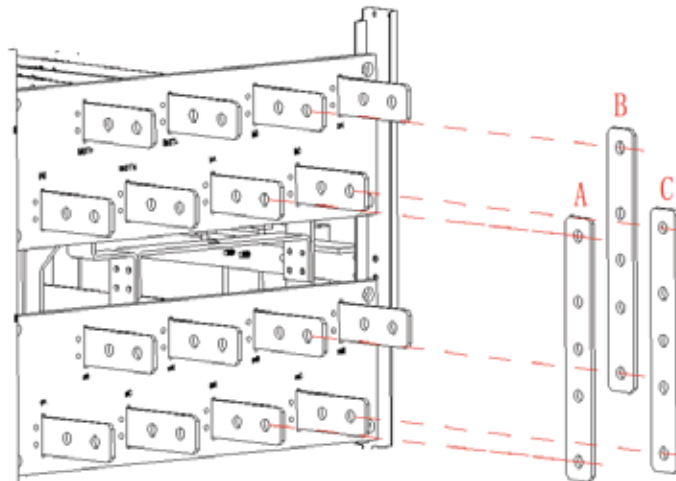

(b) 10-slot cabinet main input and bypass input short connecting copper bar diagram
Figure 3-1 Remove the main input and the bypass input short connecting copper bar

3.7 Power Cables

3.7.1 Specifications

The UPS power cables are recommended in Table 3-2.

Table 3-2 Recommended sizes for power cables

Contents		100K	120K	150K	180K	250K	300K	
Main Input	Main Input Current(A)	198	228	285	342	475	570	
	CableSection (mm ²)	A	70	95	2*70	2*70	2*120	2*150
		B	70	95	2*70	2*70	2*120	2*150
		C	70	95	2*70	2*70	2*120	2*150
		N	70	95	2*70	2*70	2*120	2*150
Main Output	Main Output Current(A)	152	182	228	273	380	456	
	CableSection (mm ²)	A	70	70	2*70	2*70	2*95	2*150
		B	70	70	2*70	2*70	2*120	2*150
		C	70	70	2*70	2*70	2*120	2*150
		N	70	70	2*70	2*70	2*120	2*150
Bypass Input	Bypass Input Current(A)	152	182	228	273	380	456	
	CableSection (mm ²)	A	70	70	2*70	2*70	2*120	2*150
		B	70	70	2*70	2*70	2*120	2*150
		C	70	70	2*70	2*70	2*120	2*150
		N	70	70	2*70	2*70	2*120	2*150
Battery Input	Battery Input current(A) (40pcs nominal 2V/cell)	208	250	312	375	520	625	
	CableSection (mm ²)	+	95	95	2*70	2*95	2*120	2*150
		-	95	95	2*70	2*95	2*120	2*150
		N	95	95	2*70	2*95	2*120	2*150
PE	CableSection (mm ²)	PE	35	50	95	120	150	185

 **Note**

The recommended cable section for power cables are only for the situations described below:

- Ambient temperature: +30°C.
- AC loss is less than 3%, DC loss is less than 1%, the length of the AC power cables should be no longer than 50 meters and the length of the DC power cables should be no longer than 30 meters.
- Currents listed in the table are based on the 380V system (line to line voltage). For 400V system, the current is 0.95 times and for the 415V system the current is 0.92 times.
- The size of neutral lines should be 1.5-1.7 times the value listed above when the predominant load is non-linear.

3.7.2 Specifications for Power Cables Terminal

Specifications for power cables connector are listed as Table 3-3.

Table 3-3 Requirements for power terminal

Type	Port	Connection	Bolt	Torque
4-slot cabinet	Mains input	Cables crimped OT terminal	M10	15Nm
	Bypass Input	Cables crimped OT terminal	M10	15Nm
	Battery Input	Cables crimped OT terminal	M10	15Nm
	Output	Cables crimped OT terminal	M10	15Nm
	PE	Cables crimped OT terminal	M10	15Nm
6-slot cabinet	Mains input	Cables crimped OT terminal	M10	15Nm
	Bypass Input	Cables crimped OT terminal	M10	15Nm
	Battery Input	Cables crimped OT terminal	M10	15Nm
	Output	Cables crimped OT terminal	M10	15Nm
	PE	Cables crimped OT terminal	M10	15Nm
10-slot cabinet	Mains input	Cables crimped OT terminal	M10	15Nm
	Bypass Input	Cables crimped OT terminal	M10	15Nm
	Battery Input	Cables crimped OT terminal	M10	15Nm
	Output	Cables crimped OT terminal	M10	15Nm
	PE	Cables crimped OT terminal	M10	15Nm

3.7.3 Circuit Breaker

The external circuit breakers (CB) for the system are recommended in Table 3-4.

Table 3-4 Recommended CB

Installed position	100k	120k	150k	180k	250k	300k
Main input CB	250A/3P	320A/3P	320A/3P	400A/3P	630A/3P	630A/3P
Bypass input CB	160A/3P	250A/3P	250A/3P	320A/3P	400A/3P	630A/3P
Output CB	160A/3P	250A/3P	250A/3P	320A/3P	400A/3P	630A/3P
Manual Bypass CB	160A/3P	250A/3P	250A/3P	320A/3P	400A/3P	630A/3P

CAUTION

The CB with RCD (Residual Current Device) is not suggested for the system.

3.7.4 Connecting Power Cables

The steps of connecting power cables are as follows:

- 1) Verify that all the external input distribution switches of the UPS are completely open and the UPS internal maintenance bypass switch is open, Attach necessary warning signs to these switches to prevent unauthorized operation.
- 2) Open the back door of the cabinet, remove the metal or plastic cover. The input and output terminal, battery terminal and protective earth terminal are shown in Figure 3-13.

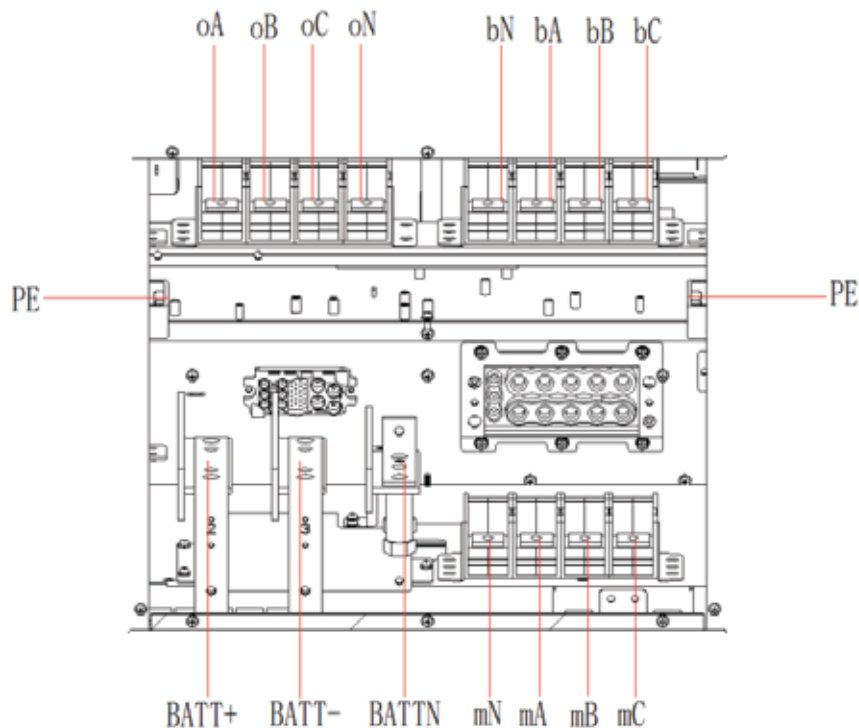

(a) 4-slot cabinet connection terminals diagram

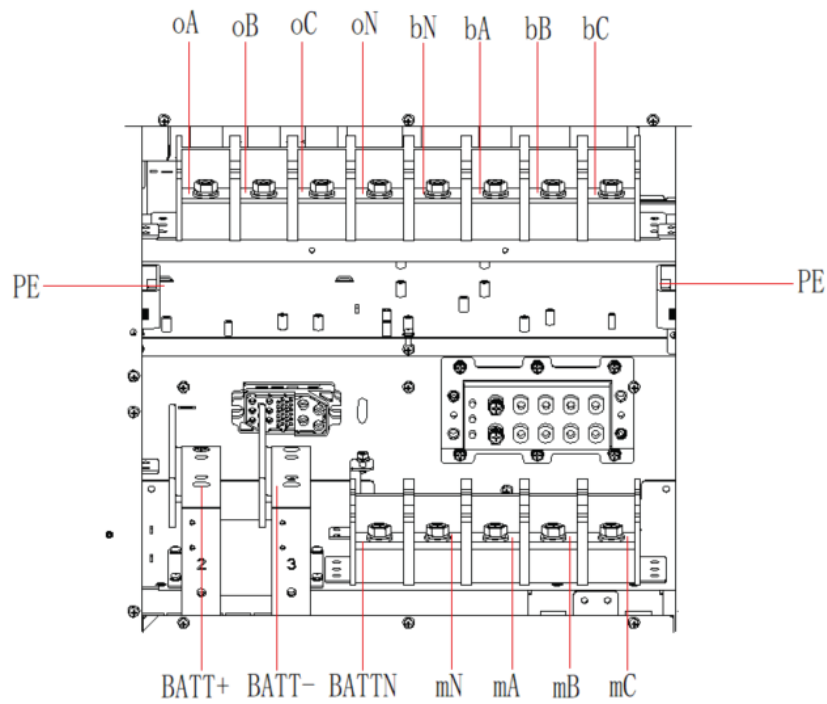

(b) 6-slot cabinet connection terminals diagram

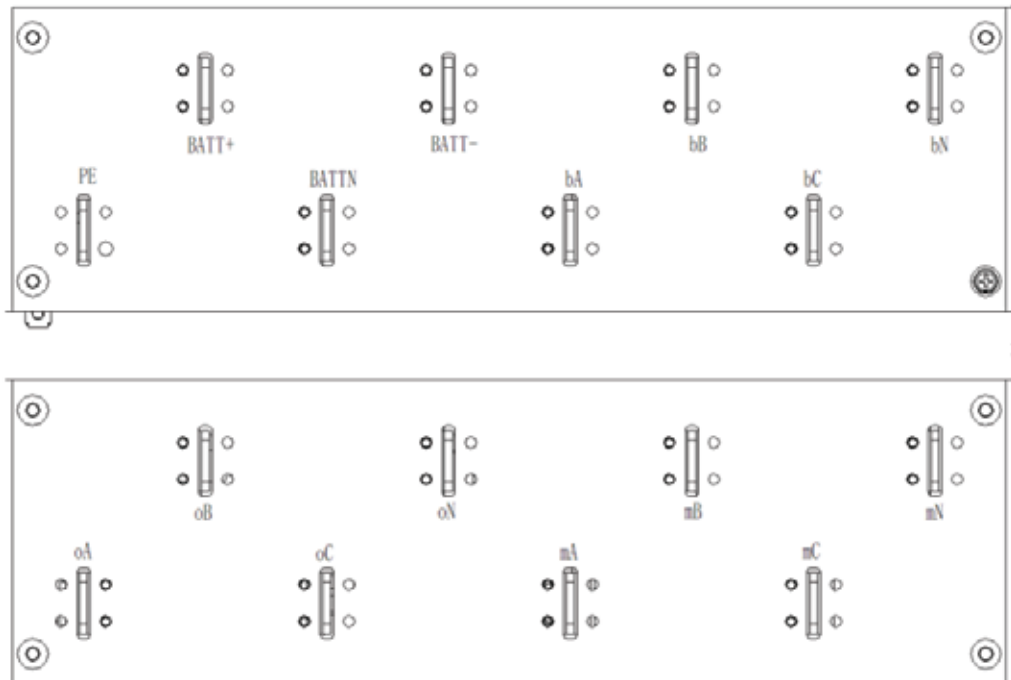

(c) 10-slot cabinet connection terminals diagram

Figure 3-13 Connection terminals layout diagram

- 3) Connect the protective earth wire to protective earth terminal (PE).
- 4) Connect the AC input supply cables to the main input terminal and AC output supply

cables to the output terminal.

5) Connect the battery cables to the battery terminal.

6) Check to ensure there is no mistake and re-install all the protective covers.

CAUTION

The operations described in this section must be performed by authorized electricians or qualified technical personnel. If you have any difficulty, please contact the manufacturer or the agency.

WARNING

- Tighten the connections terminals to enough torque moment, refer to Table 2-3 and please ensure correct phase rotation.
 - Before connection, ensure the input switch and the power supply are off, attach warnings label to warn not to operate by others
 - The grounding cable and neutral cable must be connected in accordance with local and national codes.
-

3.8 Control and Communication Cables

The front panel of the bypass module provides dry contact interface and communication interface (RS232, RS485, SNMP, Intelligent card interface and USB port), as is shown in Figure 3-14.

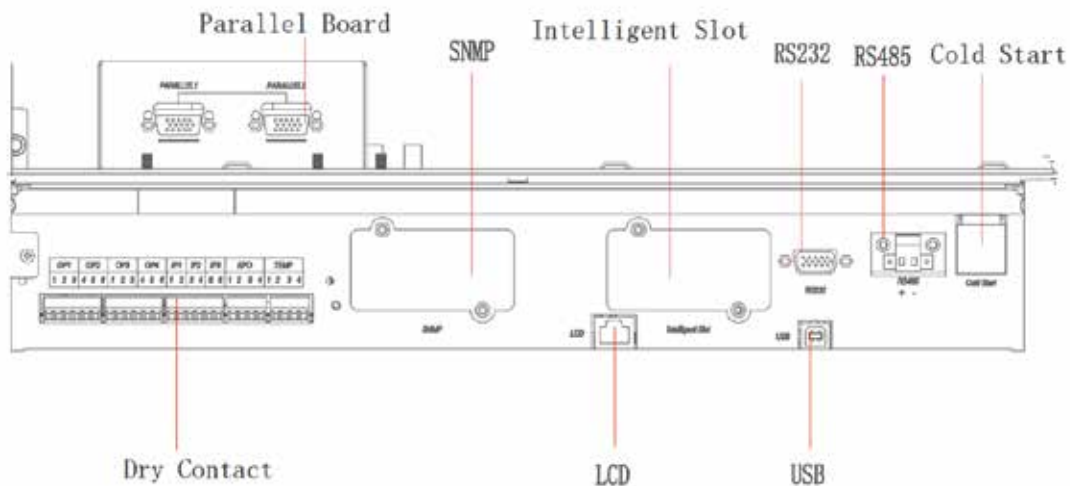

(a) Communication interface for 4-slot & 6-slot cabinet UPS

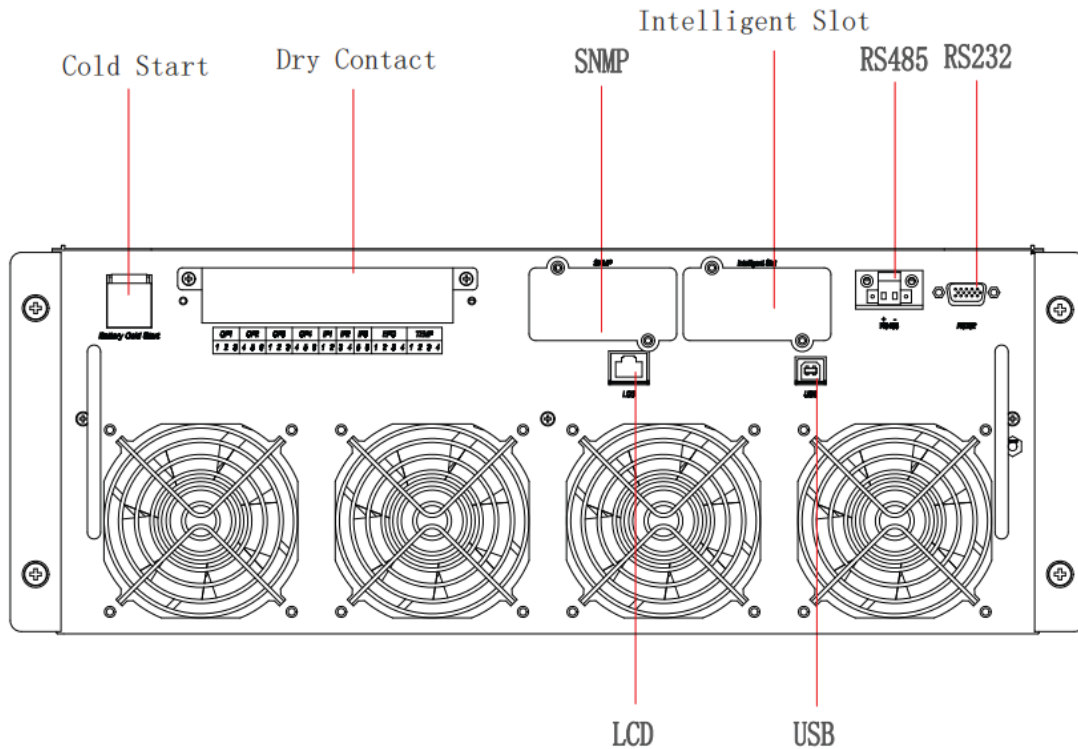

(b) Communication interface for 10-slot cabinet UPS
Figure 3-14 Communication interface diagram

The UPS can accept the external dry contact signal and send out the dry contact signal, through the phoenix terminal ports. The cables connected to the dry contact terminals must be separated from power cables. Moreover, these cables should be double insulated with a typical 0.5 to 1.5mm² cross-section areas for a maximum connection length between 25 and 50meters.

3.8.1 Dry Contact Interface

Dry contact always includes 5 sets of interfaces, and the default definitions of these ports are shown in Table 3-5.

Table 3-5 Default Functions of the ports

Port	Name	Function
EPO-1	REMOTE_EPO_NO	Trigger EPO when short- circuited with EPO-2
EPO-2	+24V_DRY	+24V
EPO-3	+24V_DRY	+24V
EPO-4	REMOTE_EPO_NC	Trigger EPO when disconnected with EPO-3
TEMP-1	ENV_TEMP	Detection of environmental temperature
TEMP-2	TEMP_COM	Common terminal for temperature detection

TEMP-3	TEMP_COM	Common terminal for temperature detection
TEMP-4	TEMP_BAT	Detection of battery temperature
IP1-1	BCB_Status	Input dry contact, the function is adjustable. Default: BCB Status & BCB Online available (when BCB Status is invalid, the alarm makes no battery)
IP1-2	GND_DRY	Ground for +24V
IP2-3	BCB_Online	Input dry contact, the function is adjustable.
IP2-4	GND_DRY	Ground for +24V
IP3-5	GEN_CONNECTED	Input dry contact, the function is adjustable. Default: Generator input
IP3-6	+24V_DRY	+24V
OP1-1	BAT_LOW_ALARM_NC	Output dry contact (Normally Closed), the function is adjustable. Default: Battery voltage low.
OP1-2	BAT_LOW_ALARM_NO	Output dry contact (Normally open), the function is adjustable. Default: Battery voltage low.
OP1-3	BAT_LOW_ALARM_GND	OP1-1 and OP1-2 Common
OP2-4	GENERAL_ALARM_NC	Output dry contact (Normally Closed), the function is adjustable. Default: General alarm
OP2-5	GENERAL_ALARM_NO	Output dry contact (Normally open), the function is adjustable. Default: General alarm
OP2-6	GENERAL_ALARM_GND	OP2-4 and OP2-5 Common
OP3-1	UTILITY_FAIL_NC	Output dry contact (Normally Closed), the function is adjustable. Default: Utility abnormal
OP3-2	UTILITY_FAIL_NO	Output dry contact (Normally open), the function is adjustable. Default: Utility abnormal
OP3-3	UTILITY_FAIL_GND	OP3-1 and OP3-2 Common
OP4-4	BCB Drive	Output dry contact, the function is adjustable. Default: Battery BCB (In the EOD or EPO available)
OP4-5	GND_DRY	Ground for +24V
OP4-6	+24V_DRY	+24V



The dry contact ports can be programmed through our background monitor software.

Remote EPO Input Port

EPO1-4 is the input port for remote EPO. It requires connecting NC (EPO-4) and +24V (EPO-3) and disconnecting NO (EPO-1) and +24V (EPO-2) during normal operations, and EPO is triggered when disconnecting NC (EPO-4) and +24V (EPO-3), or connecting NO (EPO-1) and +24V (EPO-2). The port diagram is shown in Figure 3-11, and the port description is shown in Table 3-6.

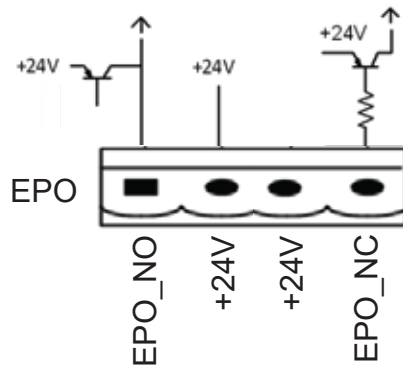

Figure 3-11 Diagram of input port for remote EPO

Table 3-6 Description of input port for remote EPO

Port	Name	Function
EPO-1	REMOTE_EPO_NO	Trigger EPO when connect with EPO-2
EPO-2	+24V_DRY	+24V
EPO-3	+24V_DRY	+24V
EPO-4	REMOTE_EPO_NC	Trigger EPO when disconnect with EPO-3



EPO-1 and EPO-2 must be disconnected in normal operations.

Interface of Battery and Environmental Temperature Detection

The input dry contact can detect the temperature of batteries and environment respectively, which can be used in environment monitoring and battery temperature compensation. Interfaces diagram for TEMP_1-4 are shown in Figure 3-12, the description of the interface is in Table 3-7.

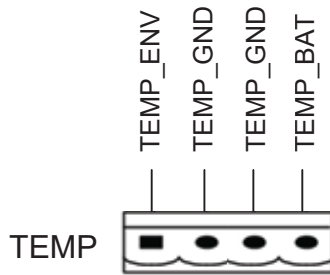

Figure 3-12 TEMP 1-4 for temperature detection

Table 3-7 Description of TEMP 1-4

Port	Name	Function
TEMP-1	ENV_TEMP	Detection of battery temperature
TEMP-2	TEMP_COM	common terminal
TEMP-3	TEMP_COM	common terminal
TEMP-4	TEMP_BAT	Detection of environmental temperature



Note

A specified temperature sensor is required for temperature detection, and it's optional, please confirm with the manufacturer or the local agency before the order.

Generator Input Dry Contact

The default function of IP3 5-6 is the interface for generator input, when connecting IP3-5 with +24V (IP3-6), the UPS judges the generator has been connected in the system. The port diagram is shown in Figure 3-13, the port description is shown in Table 3-8.

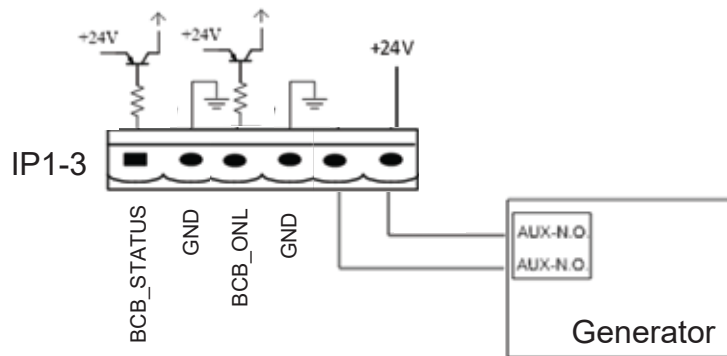

Figure 3-13 Diagram of input port for generator input

Table 3-8 Description of input port for generator input

Port	Name	Function
IP3-5	GEN_CONNECTED	Default: Generator input dry contact.
IP3-6	+24V_DRY	+24V

BCB Input Port

The default functions of OP4 4-6 are the ports for BCB tripping and BCB status, connect OP4-4 and OP4-6 to BCB tripper, the port OP4-4 can provide a driver signal (+24VDC,

100mA) to trip the battery breaker when EPO is triggered, or EOD (end of discharge) happen. The UPS would detect the BCB status, when BCB is closed, it indicates batteries are connected, when open, it alarms batteries not connected. The port diagram is shown in Figure 3-14, and the description is shown in Table 3-9.

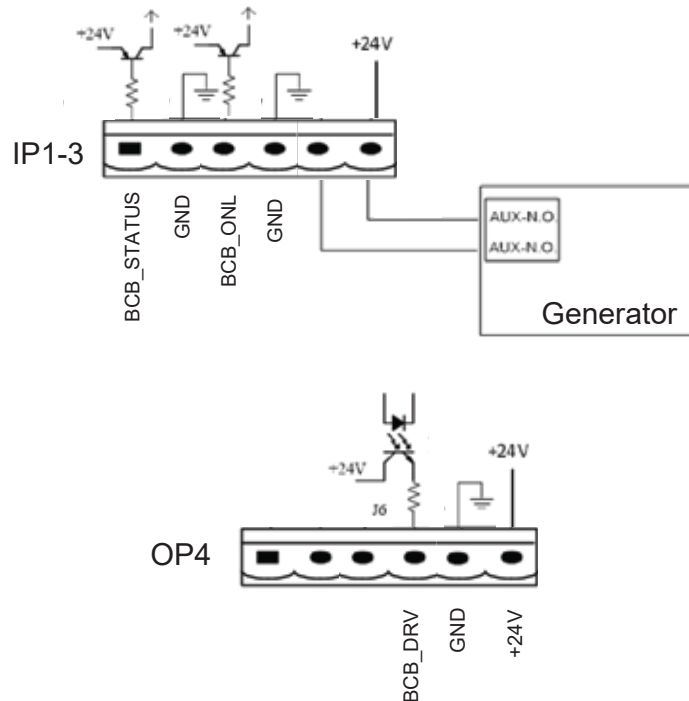

Figure 3-14 BCB Port

Table 3-9 Description of BCB port

Port	Name	Function
IP1-1	BCB_Status	BCB contact status, connect with the normally open signal of BCB
IP1-2	GND_DRY	Ground for +24V
IP2-3	BCB_Online	BCB contact status, connect with the normally open signal of BCB
IP2-4	GND_DRY	Ground for +24
OP4-4	BCB_Drive	BCB trip signal output, +24V, maximum support of 100mA
OP4-5	GND_DRY	Ground for +24V
OP4-6	+24V_DRY	+24V

Battery Warning Output Dry Contact Interface

The default function of OP1 1-3 is the output dry contact interface for battery voltage low alarm, when the battery voltage is lower than the setting value, an auxiliary dry contact signal will be activated via the relay, before UPS alarms "Battery voltage low", OP1-1 and OP1-3 are connected by the relay, OP1-2 and OP1-3 are disconnected, when UPS alarms "battery voltage low", OP1-1 and OP1-3 are disconnected by the relay, OP1-2 and OP1-3

are connected.

The port diagram is shown in Figure 3-15, and the description is shown in Table 3-10.

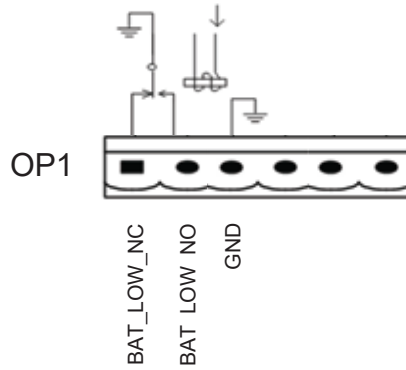

Figure 3-15 Battery warning output dry contact interface diagram

Table 3-7 Battery warning output dry contact interface description

Port	Name	Function
OP1-1	BAT_LOW_ALARM_NC	Battery warning relay (normally closed) will be open during warning
OP1-2	BAT_LOW_ALARM_NO	Battery warning relay (normally open) will be closed during warning
OP1-3	BAT LOW ALARM GND	Common terminal

General Alarm Output Dry Contact Interface

The default function of OP2 is the general alarm output dry contact dry interface. When one and more warnings are trigger, an auxiliary dry contact signal will be active via the isolation of a relay. The port diagram is shown in Figure 3-16, and the description is shown in Table 3-19.

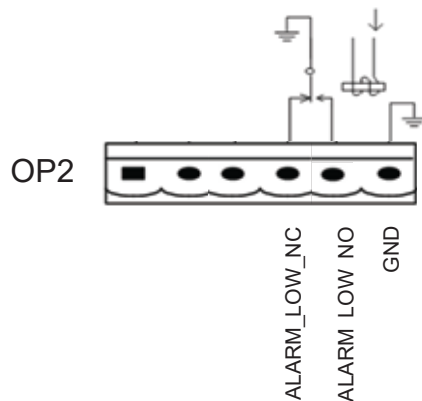

Figure 3-16 General alarm dry contact interface diagram

Table 3-8 General alarm dry contact interface description

Port	Name	Function
------	------	----------

Port	Name	Function
OP2-4	GENERAL_ALARM_NC	Integrated warning relay (normally closed) will be open during warning
OP2-5	GENERAL_ALARM_NO	Integrated warning relay (normally open) will be closed during warning
OP2-6	GENERAL_ALARM_GND	Common terminal

Utility Fail Warning Output Dry Contact Interface

The default function of OP3 is the output dry contact interface for utility failure warning, when the utility fails, the system will send a utility failure warning information and provide an auxiliary dry contact signal via the isolation of a relay. The interface diagram is shown in Figure 3-17, and the description is shown in Table 3-9.

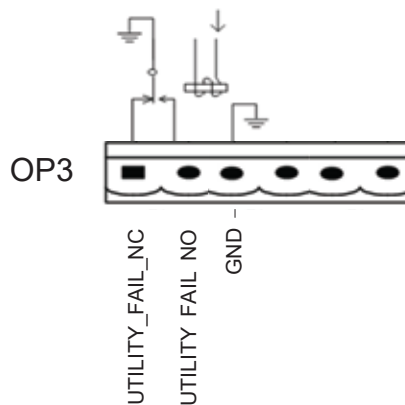

Figure 3-17 Utility failure warning dry contact interface diagram

Table 3-9 Utility failure warning dry contact interface description

Port	Name	Function
OP3-1	UTILITY_FAIL_NC	Mains failure warning relay (normally closed) will be open during warning
OP3-2	UTILITY_FAIL_NO	Mains failure warning relay (normally open) will be closed during warning
OP3-3	UTILITY_FAIL_GND	Common terminal

3.8.2 Communication Interface

RS232, RS485 and USB ports can provide series data which can be used for commissioning and maintenance by authorized engineers or can be used for networking or integrated monitoring system in the service room.

SNMP card: It is used on site for communication (Optional).

Intelligent card: It is used for extension dry contact interface (Optional).

4 UPS Control LCD Panel

4.1 UPS LCD Panel

The LCD panel for cabinet is divided into three functional areas: LED indicator, control and operation keys and LCD touch screen.

The structure of operator control and display panel for cabinet is shown in Figure 4-1.

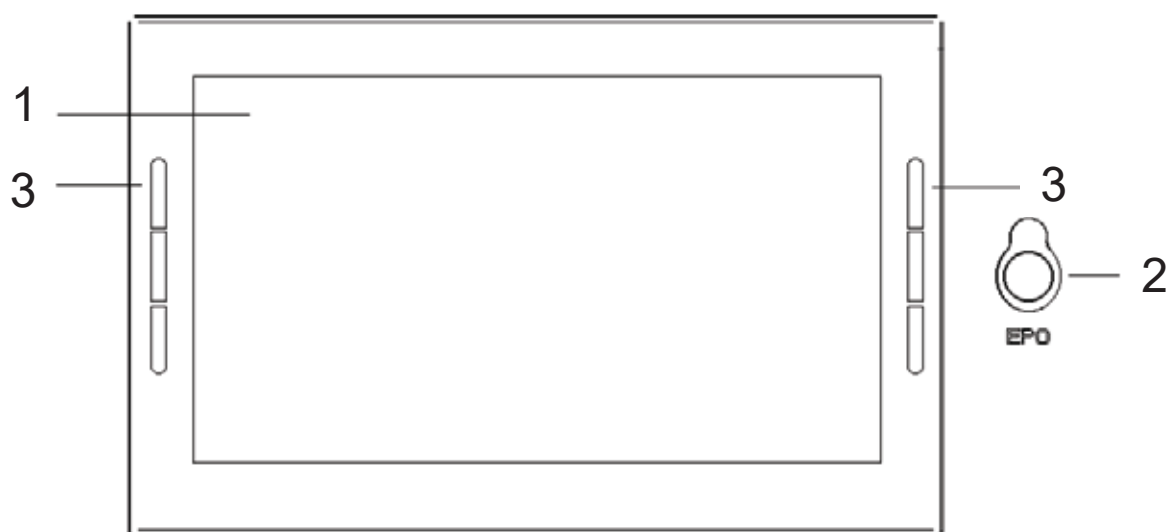

1: LCD touch screen 2: EPO switch 3: Status indicator

Figure 4-1 Control and display panel for cabinet

4.1.1 LED Indicator

There is LED on the panel to indicate the operating status and fault. The description of indicators is shown in Table 4-1.

Table 4-1 Status description of indicator

Indicator	State	Description
Status indicator	Green	Normal operation
	Red	Fault alarm
	Yellow	Warning alarm

There are two different types of audible alarm during UPS operation, as shown in Table 4-2.

Table 4-2 Description of audible alarm

Alarm	Description
Two short alarm with a long one	when system has general alarm (for example: AC fault),

Continuous alarm	When the system has serious faults (for example: fuse blown or hardware failure)
------------------	--

4.1.2 Control and Operation Keys

Control and operation keys mainly include emergency power off (EPO). The function description is shown in Table 4-3.

Table 4-3 Functions of control and operation keys

Function Key	Description
EPO	Long press, cut off the load power (shut down the rectifier, inverter, static bypass and battery)

CAUTION

When bypass frequency is over track, there is interruption time (less than 10ms) for transferring from bypass to inverter.

4.1.3 LCD Touch Screen

Users can easily browse the information, operate the UPS, and set the parameters through the LCD touch screen, which is friendly for users.

After the monitoring system starts self-test, the system enters the home page, following the welcome window. The home page is shown in Figure 4-2.



Figure 4-2 Home page

Home page consists of Status bar, Information display, warning information and main menu.

- Status Bar

The status bar contains the product, capacity, operational mode, and the number of the power module and the time of the system.

- Warning Information

Display the warning information of the cabinet. The red indicates a serious alarm, while orange indicates a general alarm.

- Information Display

Users can check the information about the cabinet in this area.

The bypass voltage, main input voltage, battery voltage, and output voltages are presented in the form of gauge. The energy flow mimics the flow of power.

- Main Menu

The main menu includes Cabinet, Module, Setting, Log, Control and Scope. Users can operate and control UPS and browse all measured parameters through main menu.

The structure of the main menu tree is shown in Figure 4-3.

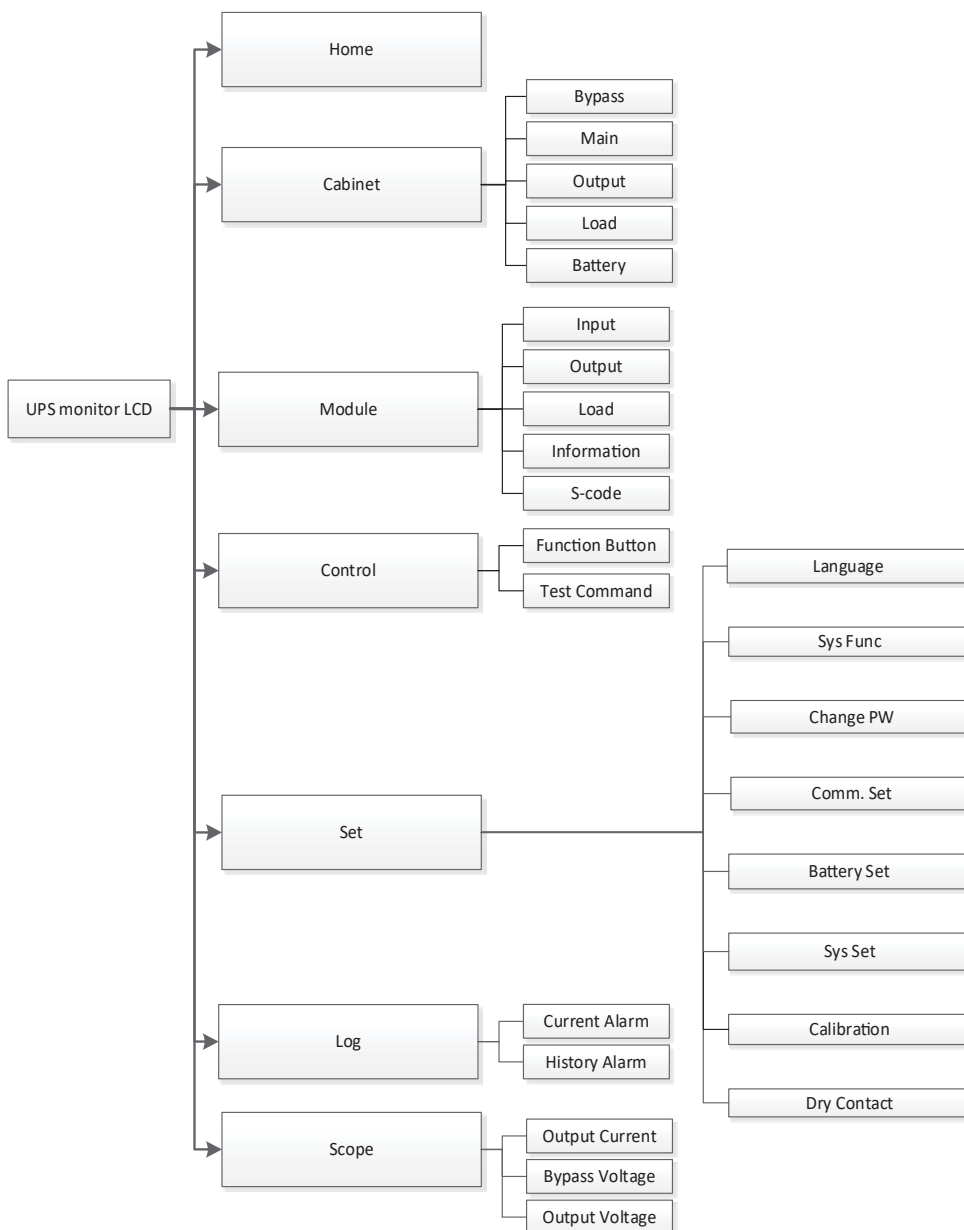

Figure 4-3 Structure of menu diagram

4.2 Main Menu

The main menu includes Cabinet, Module, Setting, Log, Control and Scope, and it is described in detail below.

4.2.1 User Login

Click on the icon  in the upper right corner of the homepage to enter the user login interface, as shown in Figure 4-4. Enter the authorized account and password to log in to the system and perform corresponding permission operations.



Figure 4-4 Login page

4.2.2 Cabinet Menu

Touch the icon  (at the left of the screen), and the system enters the page of the cabinet menu, as it is shown in Figure 4-5.



Figure 4-5 Cabinet menu

The cabinet menu interface mainly consists of sub menus for bypass, main input, output, load, and battery. Each sub-menu displays detection information for each part of the cabinet. The sub-menu of Cabinet is described in detail below in Table 4-4.

Menu information can be displayed on the next page through the flip icon 1/2 in the bottom right corner.

Table 4-4 Description of each sub-menu of Cabinet

Sub-menu	Contents	Meaning
Bypass	V	Phase voltage
	A	Phase current
	Hz	Input frequency
	PF	Power factor
Main	V	Phase voltage
	A	Phase current
	Hz	Bypass frequency
	PF	Power factor
Output	V	Phase voltage
	A	Phase current
	Hz	Output frequency
	PF	Power factor
Load	kVA	Sout: Apparent Power
	kW	Pout: Active Power
	kVar	Qout: Reactive power
	%	Load (The percentage of the UPS load)
Battery	Battery Number	Total number of battery connections per group
	Battery Status	Battery boost/float charging status
	Run time	Total battery run time
	V	Battery positive/negative Voltage
	A	Battery positive/negative Current
	Battery Capacity (%)	The percentage compared with the new battery
	Remain Time (Min)	Remaining battery backup time

Sub-menu	Contents	Meaning
	Battery Temp.(°C)	Battery temperature
	Ambient Temp.(°C)	Environmental temperature

4.2.3 Module menu

Touch the icon  (At the left of the screen), and the system enters the page of the Module menu, as is shown in Figure 4-6.



Figure 4-6 Module menu

The power module mainly menu interface includes Input, Output, Load, INFO and S-CODE etc. sub-menu.

● Power module information

- (1) Power module number, automatically displaying the power module code based on different cabinet settings.
- (2) Whether the power module is inserted and selected.
- (3) The operating status of the power module is as follows:
 - (a) The green box indicates the current module being selected for viewing.
 - (b) The black box indicates that the power module has been connected to the system and displays the status.
 - (c) If no module is displayed in the corresponding box, it means that no module has been detected in the slot.
 - (d) The status indicator lights on the right side of the module indicate the status of the input, output, and battery, with green indicating normal and red indicating abnormal.

● Version Information

Display the version information of rectifier and inverter for the selected module.

The sub-menus of Module are described below in details in Table 4-5.

Table 4-5 Description of each sub-menu of Module

Sub-menu	Contents	Meaning
Input	V	Input phase voltage of selected module
	A	Input phase current of selected module
	Hz	Input frequency of selected module
	PF	Input power factor of selected module
Output	V	Output phase voltage of selected module
	A	Output phase current of selected module
	Hz	Output frequency of selected module
	PF	Output power factor of selected module
Load	kVA	Sout: Apparent Power
	kW	Pout: Active Power
	kVar	Qout: Reactive power
	%	Load (The percentage of the UPS load)
Information	DC BUS +/- (V)	Bus voltage (positive & negative)
	Battery +/- (V)	Battery voltage (positive & negative)
	Charger (V)	Charger voltage (positive & negative)
	Charger (A)	Charger current (positive & negative)
	Discharge (A)	Discharge current (positive & negative)
	INV Voltage (V)	Inverter phase A/B/C voltage
	Fan Run Time (H)	Total fan's running time
	Capacitor Run Time (H)	Total capacitor running time
	Air Inlet Temp. (°C)	Air inlet temperature
	Air Outlet Temp. (°C)	Air outlet temperature
	REC IGBT Temp. (°C)	REC IGBT temperature of the phase A/B/C
INV IGBT Temp. (°C)	INV IGBT temperature of the phase A/B/C	
S-code	Fault Code	For the maintenance personnel

4.2.4 Set Menu

Touch the icon  (At the left of the screen), and the system enters the page of the setting, as is shown in Figure 4-7.

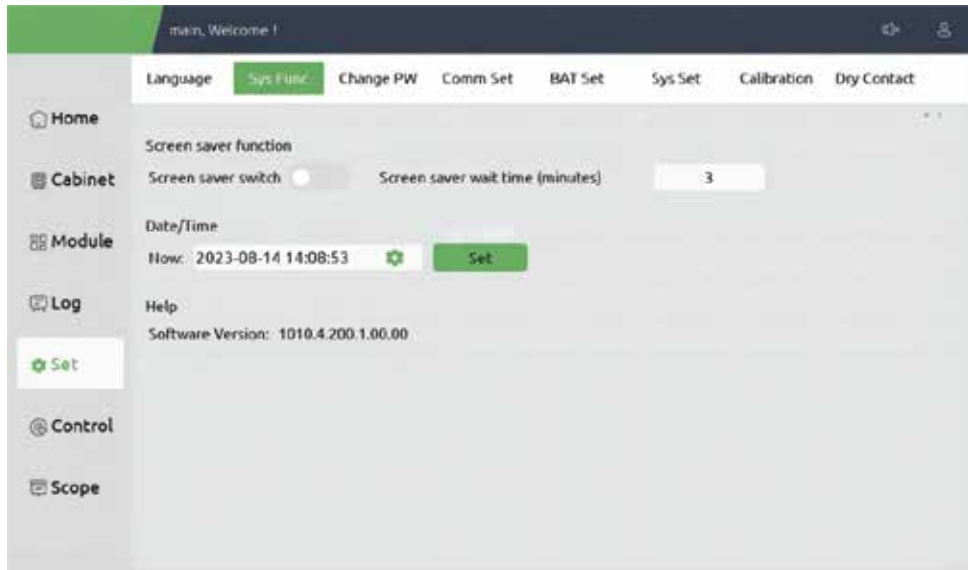

Figure 4-7 Setting menu

Under the setting menu, there are the following grading sub-menus, which are language setting, system function, network setting, general setting, communication setting, user setting, battery setting, system setting, rating setting, system code setting, calibration function and dry contact setting.

The setup subordinate sub-menu is shown in Table 4-6.

Table 4-6 Description of each sub-menu of Setting Menu

Sub-menu	Contents	Description
Language	Current language	Displays the currently selected language
	Optional language	Simplified Chinese, English and other languages for choice
Sys Func	System function setting	Setting screensaver, system time, check memory and software version
Change PW	Change password	Change the user login password
Comm Set	Comm. interface	Include RS232, RS485, USB
	Protocol	Include MEGA protocol、Modbus ASCII protocol、ModBus_RTU protocol
	Baud-rate	Setting the baud-rate
	Device Address	Setting the Device address
	Battery Number	Setting the number of the battery (12V)
	Battery Capacity	Setting of the AH of the battery
	Float Charge Voltage/Cell	Setting the floating Voltage for battery cell (2V)

Battery Set	Boost Voltage/Cell	Charge	Setting the boost Voltage for battery cell (2V)
	EOD Voltage (0.6C)		EOD voltage for cell battery, 0.6C current
	EOD Voltage (0.15C)		EOD voltage for cell battery, 0.15C current
	Charge Percent Limit	Current	Charge current (percentage of the rated current)
	Battery Compensate	Temperature	Coefficient for battery temperature
Sys Set	System Mode		Setting the system mode: Single, parallel, Single ECO, parallel ECO, LBS, parallel LBS
	United Number		Set the number of UPS in parallel system
	Cabinet ID		For parallel system, the ID starts from 0
	Output Adjustment	Voltage	Setting the Output Voltage
Calibration	Calibration parameters	product	Calibration the UPS output voltage
Dry contact	Configuration the dry contact		Configuration the dry contact



Note

1. Improper parameter settings may affect product performance, please ensure that operators receive appropriate training and authorization.
2. The C set for the battery is the ampere hour of the battery. If it is a 100AH battery, then C=100A.
3. Setting up projects may vary depending on different user permissions. For example, lithium battery settings, please contact the manufacturer.



WARNING

Ensure the number of the battery, set via the menu or the monitoring software, is completely equal to the real installed number. Otherwise, it may cause serious damage to the batteries or the equipment.

4.2.5 Log Menu

Click on the icon on the left side of the LCD screen to enter the Log menu, where history is recorded by time.

Display various events and alarm information that have occurred in the system in sequence and record the time of their set and clear. The recording menu is divided into two menus: current alarm and historical alarm. The Home screen is shown in Figure 4-8 below.

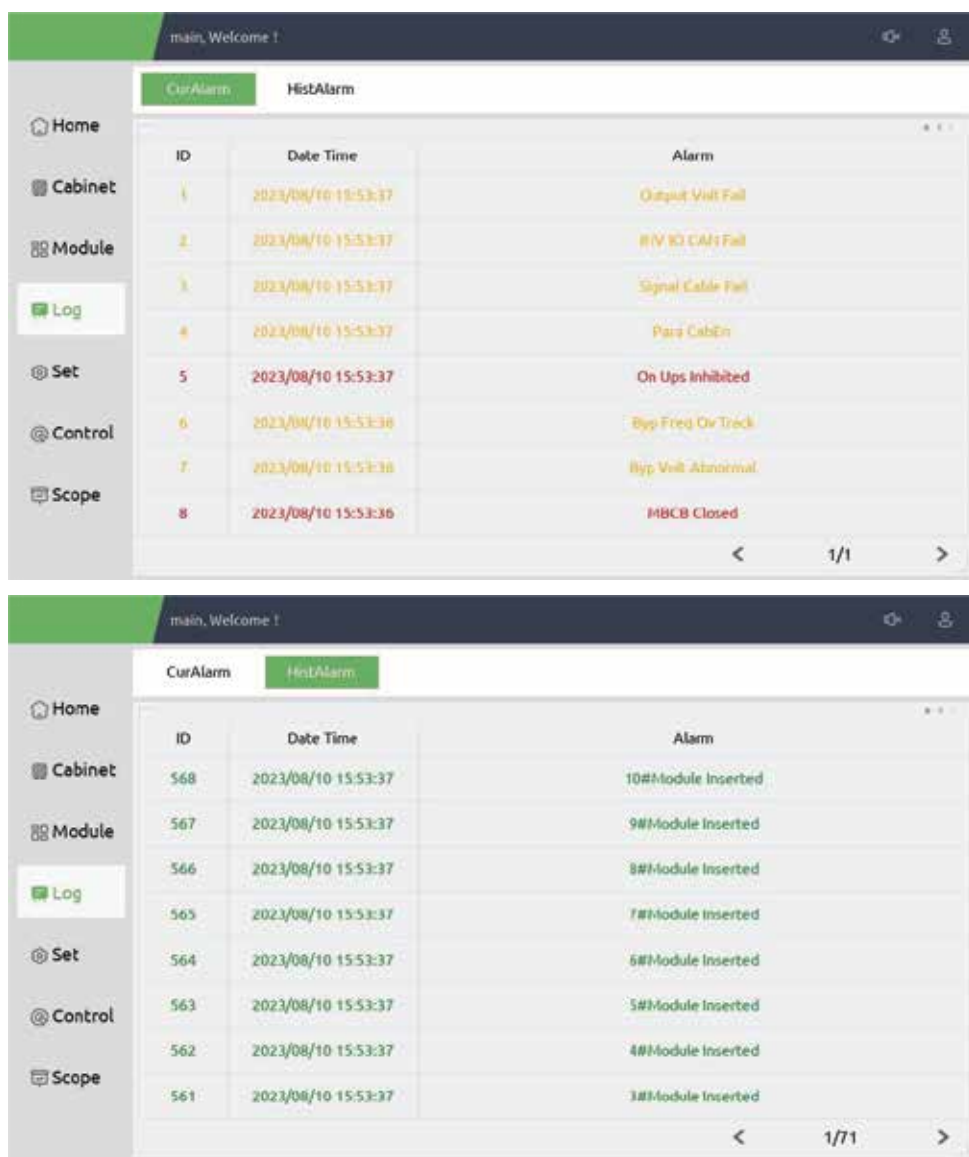

Figure 4-8 Log menu

The Table 4-7 below displays all the events and gives a brief explanation Table 4-7 the list of events

Event	Describe
-------	----------

Event	Describe
Load On UPS	The system is in a normal inverter power supply state
Load On Bypass	The system is in a bypass power state
No Load	The system has no output
Battery Boost	The battery is in Boost charging state
Battery Float	The battery is in a Floating charging state
Battery Discharge	The system operates in a battery discharge state
Battery Connected	Battery connects to the UPS
Battery Not Connected	The battery is not connected
Maintenance CB Closed	Maintenance breaker is turn on
Maintenance CB Open	Maintenance breaker is turn off
EPO	Emergency power off
EPO-Disappear	Emergency power off release
Generator Input	External generator access
Generator Input -Disappear	Disconnect the external generator
Utility Abnormal	The input mains power supply is abnormal
Utility Abnormal -Disappear	Mains power returned to normal
Bypass Sequence Error	The bypass phase sequence connect error
Bypass Sequence Error-Disappear	The bypass phase sequence connects returns to normal
Bypass Volt Abnormal	The bypass voltage is abnormal
Bypass Volt Abnormal -Disappear	The bypass voltage returns to normal
Bypass Module Fail	The bypass fails
Bypass Module Fail -Disappear	The bypass returns to normal
Bypass Overload	The bypass output is overloaded
Bypass Overload-Disappear	The bypass output returns to normal
Bypass Over Load Tout	The bypass overload continues and the overload times out.
Bypass Over Load Tout -Disappear	The bypass overload status -Cleared
Byp Freq Over Track	The bypass frequency is out of tracking range
Byp Freq Over Track -Disappear	The bypass frequency return to the tracking range

Event	Describe
Exceed Tx Times Lmt	More than 5 switching times between bypass and inverter in the last hour
Exceed Tx Times Lmt -Disappear	Disappear the number of switchovers
Output Short Circuit	The system output is short-circuited
Output Short Circuit -Disappear	The system output short circuit -Disappear s
Battery EOD	The battery voltage reaches the battery shutdown point
Battery EOD -Disappear	The battery voltage returns above the battery shutdown point
Battery Test	The system enters battery self-test mode
Battery Test OK	The system self-test battery is normal
Battery Test failed	The system self-detects a problem with the battery
Battery Maintenance	The system is in a battery maintenance state
Battery Maintenance OK	Battery maintenance status complete
Battery Maintenance failed	The battery maintenance process did not complete properly
Stop Test	The battery self-test or battery maintenance status stops
Fault Clear	Clears the failure
Log Clear	Delete all history
N#Module inserted	The N# module joins the system
N#Module Exit	The N# module exits the system
N#Rectifier Fail	The N# module rectifier has failed
N#Rectifier Fail -Disappear	N# module rectifier fault clear
N#Inverter Fail	The N# module inverter has failed
N#Inverter Fail -Disappear	N# module inverter fault -Disappear
N#Rectifier Over Temp	N# The module rectifier is over-temperature
N#Rectifier Over Temp -Disappear	N# module rectifier over-temperature
N#Fan Fail	The N# module fan is faulty, not connected or stalled
N#Fan Fail -Disappear	The N# fan returns to normal
N# Output Overload	The N# module output is overloaded
N# Output Overload -Disappear	N# module output overload clear

Event	Describe
N# Inverter Overload Tout	The N# module output is overloaded with a timeout
N# Inverter Overload Tout-Disappear	The N# module output overloaded timeout clear
N# Inverter Over Temp	The inverter of the N# module is overheated
N#Inverter Over Temp-Disappear	The over temperature of the N# module inverter-Disappears
On UPS Inhibited	The inverter prohibits power supply
On UPS Inhibited-Disappear	The inverter forbidden -Disappear
Manual Transfer Byp	Manually transfer the system to the bypass
Esc Manual Transfer Byp	Manually transfer the system to the normal
Battery Volt Low	The battery voltage low
Battery Volt Low-Disappear	The battery voltage returns to normal
Battery Wiring Error	The battery cables connect reverse
Battery Wiring Error-Disappear	The battery cables connect normal
N#Inverter Protect	The N# module has inverter protection
N#Inverter Protect-Disappear	The N# module has inverter protection -Cleared
Input Neutral Lost	Input N line disconnect
Bypass Fan Fail	The bypass module fan fault
Bypass Fan Fail-Disappear	The bypass module fan fault -Cleared
N#Manual Shutdown	The N# module shuts down manually
Manual Boost Charge	Manually adjust to the boost charging
Manual Float Charge	Manually adjust to the floating charge
UPS Locked	UPS lock shutdown occurs
Parallel Cable Error	The parallel cable connect fail
Parallel Cable Error-Disappear	The parallel cable connects normal
N#Battery or Charger Fail	The N# module has battery or charger fail
N#Battery or Charger Fail-Disappear	The N# module has battery or charger fail-Disappear
N+X Redundant Lost	The cabinet lost N+X redundant function
N+X Redundant Lost-Disappear	The cabinet recover N+X redundant function
EOD System Inhibited	

Event	Describe
EOD System Inhibited-Disappear	
Signal Cable Fail	The signal cables connect fail
Signal Cable Fail-Disappear	The signal cables connect returns to normal
Ambient Over Temp.	The battery ambient temperature over setting range
Ambient Over Temp.-Disappear	The battery ambient temperature is less setting range
REC CAN Fail	The monitor unit rectifier CAN signal abnormal
REC CAN Fail-Disappear	The monitor unit rectifier CAN signal returns to normal
INV IO CAN Fail	The monitor unit inverter CAN signal abnormal
INV IO CAN Fail-Disappear	The monitor unit inverter CAN signal returns to normal
INV DATA CAN Fail	The monitor unit inverter CAN data abnormal
INV DATA CAN Fail-Disappear	The monitor unit inverter CAN data returns to normal
N#Power Share Fail	The difference of two or more power modules' output current in system is over limitation
N#Power Share Fail-Disappear	Output current difference returns to normal
Sync Pulse Fail	The synchronization signal of each module is abnormal
Sync Pulse Fail -Disappear	The synchronization signal of each module returns to normal
N#Input Volt Detect Fail	The N# module input voltage value is abnormal
N#Input Volt Detect Fail -Disappear	The N# module input voltage value returns to normal
N#Battery Volt Detect Fail	The N# module battery voltage value is abnormal
N#Battery Volt Detect Fail -Disappear	The N# module battery voltage was detected to return to normal
N#Output Volt Detect Fail	The N# module output voltage value is abnormal
N#Output Volt Detect Fail -Disappear	The N# module input voltage value returns to normal
N#Bypass Volt Detect Fail	The N# module bypass voltage value is abnormal
N#Bypass Volt Detect Fail -Disappear	The N# module bypass voltage value returns to normal
N#INV Bridge Fail	The N# module inverter is faulty
N#INV Bridge Fail -Disappear	The N# module inverter faulty -Cleared

Event	Describe
N#Outlet Temp. Error	The N# module outlet temperature is not within the set range
N#Outlet Temp. Error-Disappear	The N# module outlet temperature returns to the normal range
N#Input Curr Unbalance	There is a difference in the three-phase input current of the N# module
N#Input Curr Unbalance -Disappear	The N# module input current returns to normal
N#DC Bus Over Volt	The N# module bus voltage is overvoltage
N#DC Bus Over Volt -Disappear	The N# module bus voltage returns to normal
N#REC Soft Start Fail	The N# module rectifier could not be started
N#REC Soft Start Fail -Disappear	The N# module rectifier returned to normal
N#Relay Connect Fail	The N# module inverter relay is open
N#Relay Connect Fail -Disappear	The N# module relay is closed
N#Relay Short Circuit	The N# module inverter switch is short-circuited
N#Relay Short Circuit -Disappear	The N# module inverter switch is short-circuited returns to normal
N#PWM Sync Fail	The rectifier and inverter PWM synchronization signals are abnormal
N#PWM Sync Fail -Disappear	The rectifier and inverter PWM synchronization signals return to normal
N#Intelligent Sleep	The N# module system enters Smart Sleep
N#Intelligent Sleep -Disappear	The N# module exit Smart Sleep
Manual Transfer to INV	Manually switch to inverter
N#Input current limit Tout	The N# module input current limit time is up
N#Input current limit Tout -Disappear	The N# module input current limit time -Cleared
N#No Inlet Temp. Sensor	The N# module air inlet temperature probe is not connected or disconnected
N#No Inlet Temp. Sensor -Disappear	The N# module inlet temperature probe returns to normal
N#No Outlet Temp. Sensor	The N# module outlet temperature probe is not connected or disconnected
N#No Outlet Temp. Sensor	The N# module outlet temperature probe returned to

Event	Describe
-Disappear	normal
N#Inlet Over Temp.	The N# module air inlet temperature is too high
N#Inlet Over Temp -Disappear	The N# module air outlet temperature returned to normal
N#Capacitor Time Reset	The N# module clears the capacitor cumulative runtime record
N#Fan Time Reset	The N# module clears the fan cumulative runtime record
Battery History Reset	Clear battery history data
Battery Over Temp.	The battery is overheated
Battery Over Temp.-Disappear	The battery overheat -Cleared
Bypass Fan Expired	Reached the bypass fan repair period
Bypass Fan Expired -Disappear	Reaching Bypass fan maintenance period alarm -Disappear
Capacitor Expired	Reached the bypass fan repair period
Capacitor Expired -Disappear	Reaching Bypass fan repair period -Cleared
Fan Expired	Module fan maintenance cycle time is up
Fan Expired -Disappear	Reaching Module fan maintenance cycle -Cleared
N#INV IGBT Driver Block	The N# module inverter driver signal block
N#INV IGBT Driver Block-Disappear	The N# module inverter driver signal block turns to normal
Dust Filter Expired	Dust filter maintenance time is up
Dust Filter Expired-Disappear	Dust filter maintenance time -Cleared
Battery Expired	Battery maintenance period is up
Battery Expired -Disappear	The battery maintenance period -Cleared
BMS RS485 Error	The BMS communication fail
BMS RS485 Error-Disappear	The BMS communication failure returns to normal
CAN Error	The monitor unit CAN signal fail
CAN Error-Disappear	The monitor unit CAN signal returns to normal
Cell Undervoltage	The single cell battery voltage low
Cell Undervoltage-Disappear	The single cell battery voltage returns to normal
Cell Overvoltage	The single cell battery voltage high

Event	Describe
Cell Overvoltage-Disappear	The single cell battery voltage returns to normal
Cell Volt Difference Fail	Excessive voltage difference between single cell battery
Cell Volt Difference Fail-Disappear	The single cell battery voltage returns to normal
Batt Low Temperature	The battery ambient temperature too low
Batt Low Temperature-Disappear	The battery ambient temperature returns to normal
Battery Over Temp.	The battery ambient temperature too high
Battery Over Temp.-Disappear	The battery ambient temperature returns to normal
BMS Charge Inhibited	The BMS system prohibits charging the battery
BMS Charge Inhibited-Disappear	The BMS system recovers the charging function
BMS Discharge Inhibited	The BMS system prohibits discharging the battery
BMS Discharge Inhibited-Disappear	The BMS system recovers the discharging function
Wave Trigger	Wave Trigger
Bypass CAN Fail	The monitor unit bypass CAN signal abnormal
Bypass CAN Fail-Disappear	The monitor unit bypass CAN signal returns to normal
Bypass Power Fuse Fail	The bypass power fuse disconnects
Bypass Power Fuse Fail-Disappear	The bypass power fuse normal
Firmware Error	Software version error
Firmware Error-Disappear	Software version update to normal version
System Setting Error	System setting error
Bypass Over Temp.	The bypass module over temperature
Bypass Over Temp.-Disappear	The bypass module temperature returns to normal
Module ID Duplicate	At least two modules are set as same ID
Module ID Duplicate-Disappear	The module setting correct ID returns to normal
Electrolyte Leakage	The battery electrolyte leakage alarm
Electrolyte Leakage-Disappear	The battery electrolyte leakage alarm -Cleared



Different colors of the words represent different levels of events:

(a)Green, an event occurs or cleared

(b)Yellow, warning occurs

(c) Red, faults happen.

4.2.6 Control Menu

Touch the icon  (at the left of the screen), and the system enters the page of the "Control",

The control menu include "Func Button" & "Test Command", as it is shown in Figure 4-9& Figure 4-10.

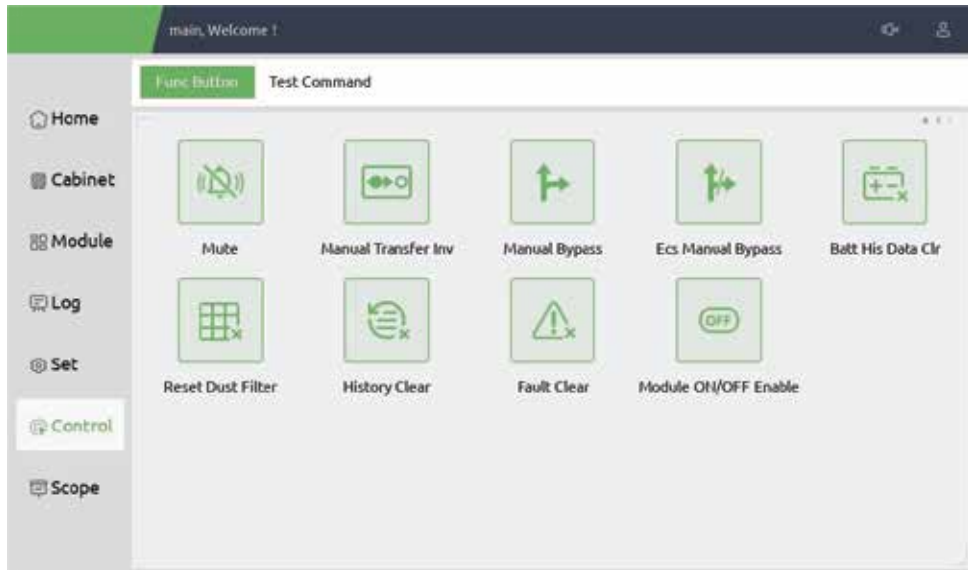

Figure 4-9 Control-Function Button menu

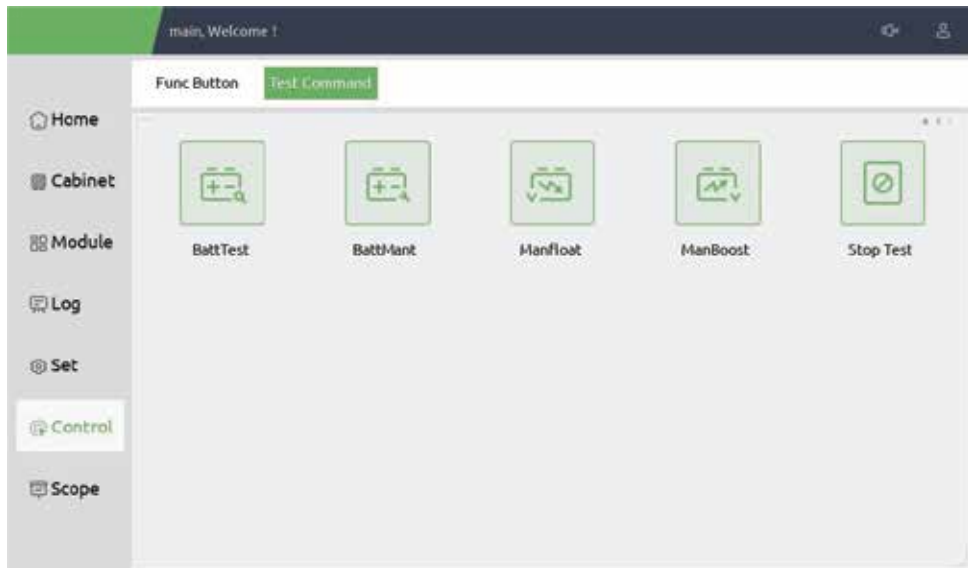

Figure 4-10 Control-Test Command menu

The "Control" menu includes "Func Button" and "Test Command". The contents are described in detail below.

Function Button

Mute and Unmute

Mute or unmute alarm of the system by touching the icon



Fault Clear

Clear the faults by touching the icon



Manual Bypass and ESC Manual Bypass

Transfer to bypass mode or cancel this command by touching the icon



Manual Transfer Inv

Transfer the bypass mode to Inverter Mode by touching the icon



Battery History Data Clear

Clear the battery history data by touching the icon , the history data includes the times of discharge, days for running and hours of discharging.

Reset Dust Filter

Reset the dust filter using by touching the icon , it includes the days of using and maintenance period.

Test Command

Battery Test

By touching the icon , the system transfers to the battery mode to test the condition of the battery. Ensure the bypass is working normally and the capacity of the battery is no less than 25%.

Battery Maintenance



By touching the icon **BattMant**, the system transfers to the battery mode. This function is used for maintaining the battery, which requires the normality of the bypass and minimum capacity of 25% for the battery.

Battery Boost



By touching the icon **ManBoost**, the system starts boost charging.

Battery Float



By touching the icon **Manfloat**, the system starts float charging.

Stop Test



By touching the icon **Stop Test**, the system stops battery test or battery maintenance.

4.2.7 Scope Menu

Click the icon  at the bottom of the LCD screen, enter the waveform menu, which mainly provides the output voltage, output current, bypass voltage and other waveforms, convenient for users to observe intuitively. As shown in Figure 4-11 below, click the upper menu option, and the display area will show the corresponding waveform, where the yellow, green and blue will represent the corresponding ABC phase respectively.



Figure 4-11 Scope menu

5 Operations

5.1 UPS Start-up

5.1.1 Startup in Normal Mode

The UPS must be started up by commissioning engineer after the completeness of installation. The steps below must be followed:

- 1) Ensure all the circuit breakers are open.
- 2) For cabinet system, one by one to turn on the output breaker (Q4), input breaker (Q1), bypass input breaker (Q2), and then the system starts initializing. (For UPS cabinet systems, there is only one manual bypass breaker in the cabinet, please one by one to turn on the external input breaker, the external bypass breaker, and then the system starts initializing.)
- 3) The LCD in front of the cabinet is lit up. The system enters the home page, as shown in Figure 4-2.
- 4) Notice the energy bar in the home page, the ups system rectifier is starting up. The power module LED indicators green.
- 5) After about 30 seconds, the "REC" indicator goes steady green; it means the finish of the rectifier startup. And at the same time the static bypass switch closes, and then the inverter starts up. The inverter LED indicators green flashing.
- 6) After 90 seconds, the UPS transfers from the bypass to the inverter after the inverter goes normally. The "BYP" LED indicators off, the "INV" LED indicator and load LED indicator green.
- 7) The UPS is in normal mode. Close the external battery circuit breaker and the UPS starts charging batteries. The Battery LED indicators off.
- 8) The startup has finished, users can close the external main output breaker and then close the branch breakers one by one.



Note

- When the system starts, the stored setting will be loaded.
- Users can browse all events during the process of the startup by checking the menu Log.

5.1.2 Start from Battery

The start from battery refers to the battery cold start. The steps of the start-up are as follows:

- 1) Confirm the batteries are correctly connected, and at least one power module is installed into the cabinet and then close the external battery circuit breakers.

2) Press the red battery start button for 3 seconds, as shown in Figure 5-1, when the monitoring module starts working.

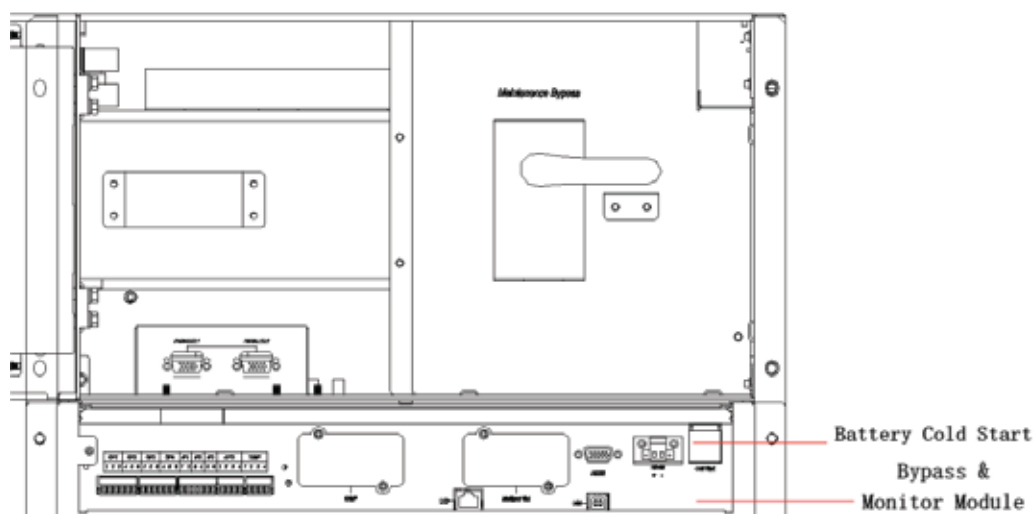

(a) 4-slot & 6-slot cabinet battery cold start

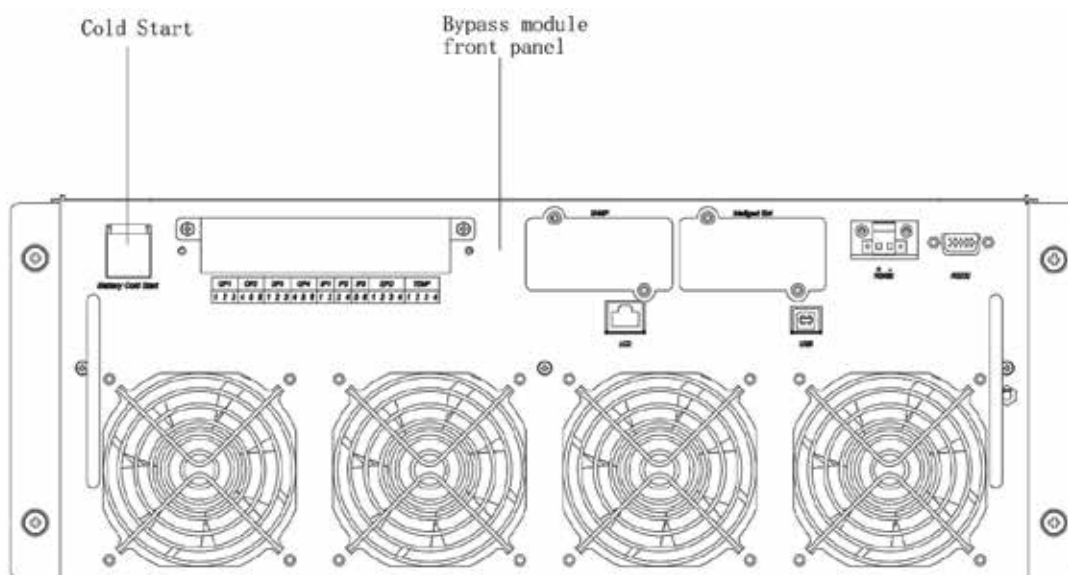

(b) 10-slot cabinet battery cold start

Figure 5-1 Monitor module battery cold start button position

3) Subsequently, the cold start button of the module is pressed, as shown in Figure 5-2, the module starts working and the system starts following the step after step 3 under normal mode startup. The system starts with the rectifier, and then starts the inverter to complete the inverter output, The whole process is about 60S, and the system operates in battery mode.

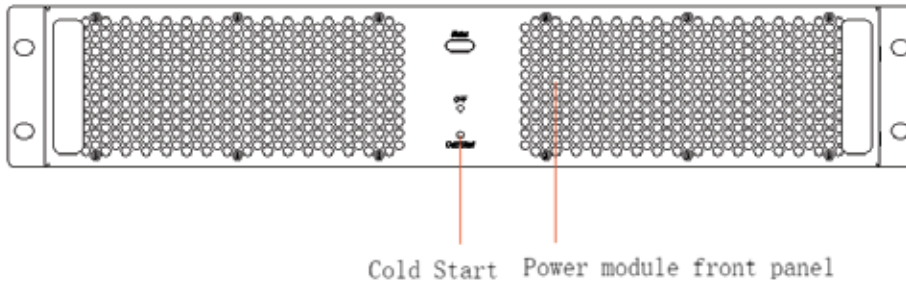

Figure 5-2 Power module battery cold start button position

4) Turn on the external output breaker is to power supply the loads, and the system is working in battery mode.

5.2 UPS Shut down

If you want to shut down UPS completely, please first ensure the load is shut down correctly, and then turn off the external battery breaker, the main input breaker (internal or external), the bypass input breaker (internal or external, if have) one by one, the display screen will be off completely.

Note: If UPS is in maintenance bypass mode, please also turn off the maintenance bypass breaker.

5.3 Procedure for Switching between Operation Modes

5.3.1 Switching the UPS from Normal Mode into Battery Mode

The UPS transfers to battery mode immediately after the utility (mains voltage) fails or drops below the predefined limit.

5.3.2 Switching the UPS from Normal Mode into Bypass Mode



Enter the menu "Control", touch the icon "transfer to bypass" and the system should transfer to bypass mode.

WARNING

Ensure the bypass is working normally before transferring to bypass mode. Or it may cause failure.

5.3.3 Switching the UPS into Normal Mode from Bypass Mode



Enter the menu "Control", touch the icon "Ecs Manual Bypass" and the system should transfer to Normal mode.



Normally, the system will transfer to the normal mode automatically. This function is used when the frequency of the bypass is over track and when the system needs to transfer to Normal mode by manual.

5.3.4 Switching the UPS into Maintenance Bypass Mode from Normal Mode

These following procedures can transfer the load from the UPS inverter output to the maintenance bypass supply.

1. Transfer the UPS into bypass mode following as per chapter 5.3.2.
2. The inverter indicator is off, the status indicator is off, and the buzzer is alarm. The load is switched to the static bypass, and the inverter is closed.
3. Turn off the battery breaker, turn on the manual bypass breaker, and the load is jointly supplied by the manual bypass breaker and the static bypass.
4. At this time, the bypass module can be pulled out, and the system supplies the load power through the manual bypass breaker.



- The UPS system only has a manual bypass breaker. In manual bypass mode (The manual bypass supplies power to loads), dangerous voltages are present on terminal and internal Copper bar.
- The UPS need to use external circuit breakers (Includes external input breaker, external bypass input breaker, external output breaker and external maintenance bypass breaker).



Before making this operation, please read messages on LCD display to ensure that bypass supply is regular and the inverter is synchronous with it, so as not to risk a short interruption in powering the load.



If you need to maintain the power module, wait for 5 minutes to let the DC bus capacitor fully discharge before removing the cover.

5.3.5 Switching the UPS into Normal Mode from Maintenance Bypass Mode

These following procedures can transfer the load from the maintenance bypass mode to the inverter output.

1. After power-on, wait for about 30S, the static bypass breaker is turned on, the bypass indicator light becomes green, and the load is jointly supplied by static bypass and manual bypass.
2. Turn off the manual bypass breaker, and the load is powered by the static bypass.
3. After 30 seconds, the rectifier is started. The indicator light is green, and the inverter is started.

After one minute, switch to the inverter mode, and the system returns to the normal mode.

5.4 Battery Maintenance

If batteries are not in use for a long time, it is necessary to test the condition of the battery. Two methods are provided:

- 1) Manual discharge test. Enter the "Control" menu, as is shown in Figure 5-3 and touch



the icon "Battery maintenance"  , the system transfers into battery mode for discharging. The system will stop discharging when batteries have 20% of capacity or in



low voltage. Users can stop discharging by touching the "Stop Test" icon  .

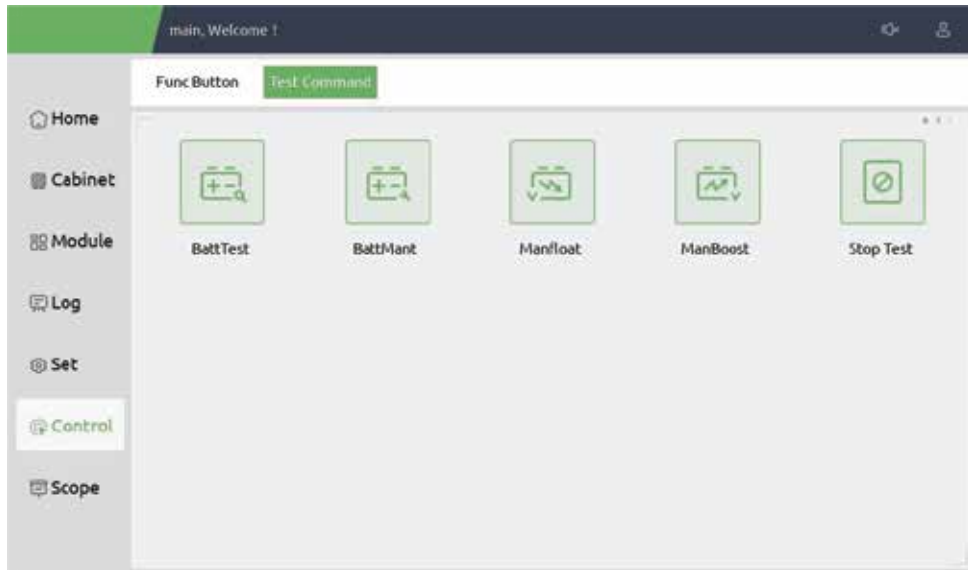

Figure 5-3 Battery maintenance

2) Auto discharging. The system can be set to discharge automatically per a certain time. The setting procedures are as follows. (this needs to be done by factory or connect the background monitor software operation).

a) Enable "battery auto discharge". Enter the "Set" page of the setting menu, tick "Battery Auto Discharge" and confirm.

b) Setting the period for "battery auto discharge". Enter the "Battery Set" page of the setting, set the period time in the item "Auto Maintenance Discharge Period" and confirm.

WARNING

The load for the auto maintenance discharge should be 20%-100%, if not, the system will not start the process automatically.

5.5 EPO

The EPO button located in the operator control and display panel (with cover to avoid wrong usage see Figure 5-4) is designed to switch off the UPS in emergency conditions (e.g. fire, flood, etc.) To achieve this, just press the EPO button, and the system will turn off the rectifier, the inverter and stop powering the load immediately (including the inverter and the bypass), and the batteries stop charging or discharging.

If the input utility is present, the UPS control circuit will remain active; however, the output will be turned off. To completely isolate the UPS, users need to switch off the external mains input supply to the UPS. Users can restart the UPS by powering the UPS again.

WARNING

When the EPO is triggered, the load is not powered by the UPS. Be careful to use the EPO function.

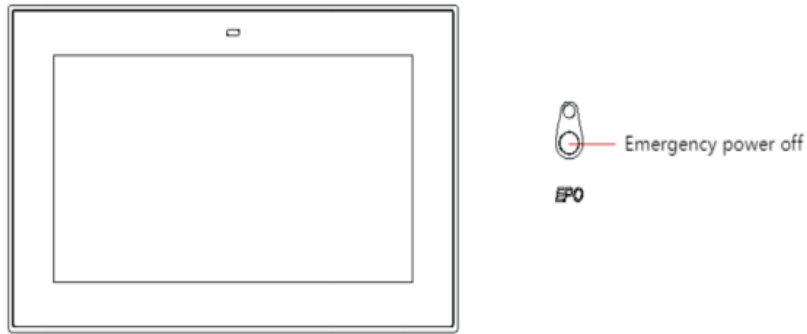

Figure 5-4 EPO Button

5.6 Installation of Parallel Operation System

For UPS system, normally 3 cabinets can be parallel; and the parallel function is optional, if users need the function, please confirm the configuration with the supplier in advance. The parallel structure diagram as shown below figure 5-5.

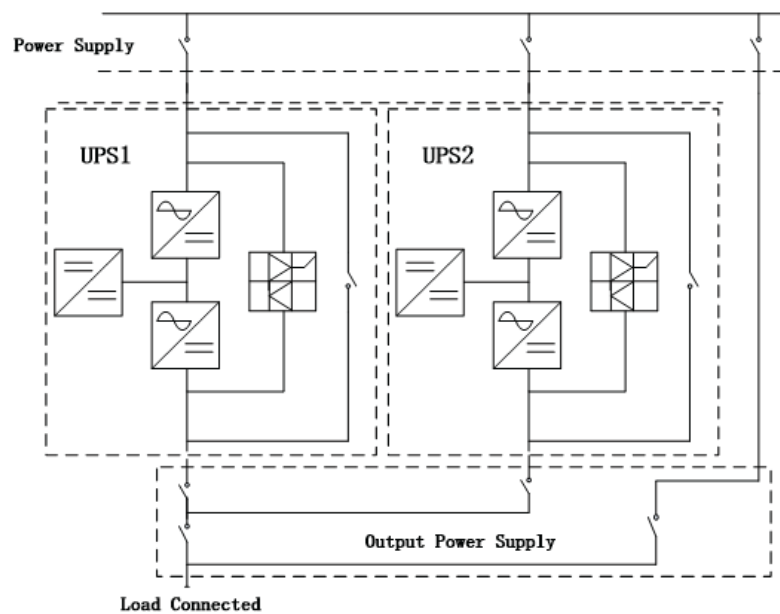
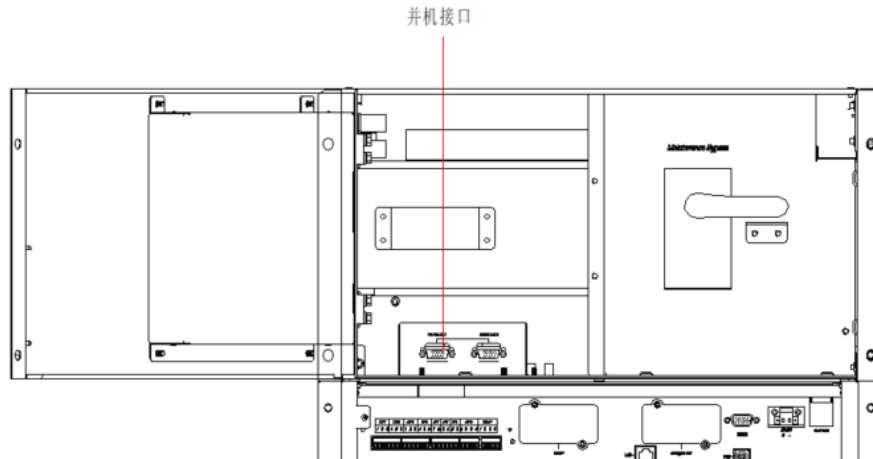

Figure 5-5 Parallel structure diagram

The parallel board is located on the front panel of the 4-6 slots cabinet, differently located back door of the 10-slots cabinet. Its location is shown in Figure 5-6.

Parallel Port



(a) 4-6 slot cabinet UPS parallel connect port position

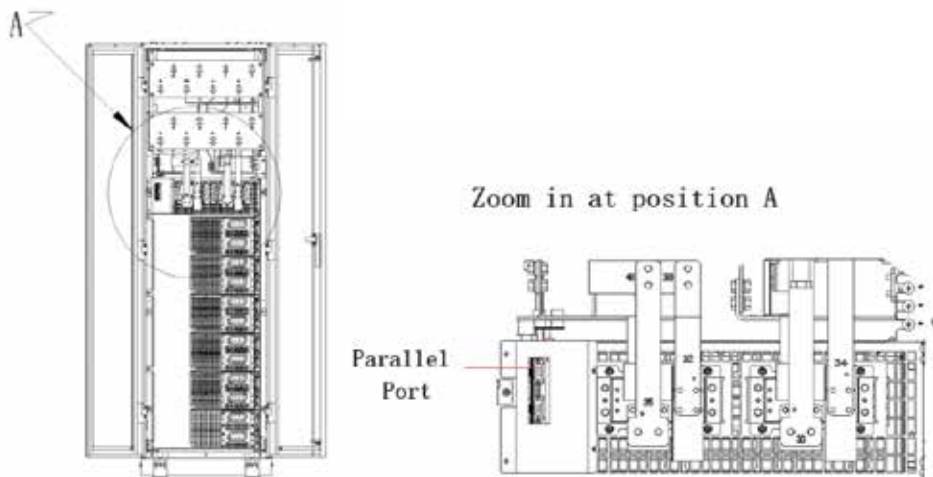

(b) 10-slot cabinet UPS parallel connect port position

Figure 5-6 UPS parallel connect port position

The parallel cables need to be connected to a cycle, the connect way as shown below figure 5-7.

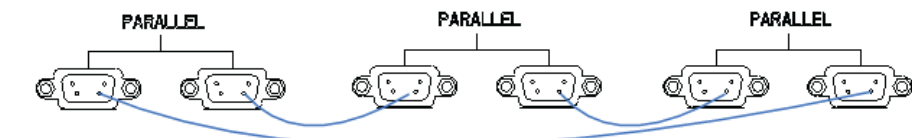

Figure 5-7 Parallel schematic diagram

For the detailed process of integration, refer to the Parallel Operation Manual.

6 Maintenance

This chapter introduces UPS maintenance, including the maintenance instructions of power module and monitoring bypass module and the replacement method of dust filter.

6.1 Precautions

Only maintaining engineers can maintain the power module and monitoring bypass module.

- 1) The power module should be disassembled from top to bottom, to prevent any inclination from high gravity center of the cabinet.
- 2) To ensure safety before maintaining power module and bypass module, use a multi-meter to measure the voltage between operating parts and the earth to ensure the voltage is lower than hazardous voltage, i.e. DC voltage is lower than 36Vdc, and AC maximum voltage is lower than 30 Vac.
- 3) Bypass module is not recommended to hot swap; only when UPS is in Manual Bypass Mode or UPS is completely powered off, the bypass module can be disassembled.
- 4) Wait 10 minutes before opening the cover of the power module or the bypass after pulling out from the cabinet.

6.2 Instruction for Maintaining Power Module

Confirm the UPS is operating in normal mode, and the bypass is working normally before pulling out the power module needed to be repaired.

- 1) Ensure the remaining power module will not be overloaded. If there is overload risk, manually transfer the UPS system to bypass mode (refer to section 5.3.2).
- 2) Power off the module.

a) Press LCD panel > Menu "Control"  > Enable Module "ON/OFF" key



- b) Press the "OFF" key for 3 seconds, the power module quits from the system.
- 3) After 10 minutes, remove the mounting screw on the two-front side of the power module and pull out the module by two persons.
- 4) After completing the power module maintenance, push the power module into the cabinet (each power module is over 10s) and tighten the screws on both sides. The power module will automatically start and join the system.
- 5) If in Step 1: manually transfer the UPS system to bypass mode. After the power module starts for 2 minutes, restore the UPS system to normal mode. Please refer to Section 5.3.3.

6.3 Instruction for Maintaining the Monitor & Bypass Unit

Confirm the UPS is operating in normal mode, and the bypass is working normally.

- 1) Use the LCD screen, switch the system into maintenance bypass mode, the load is powered by maintenance bypass.
- 2) Turn on the maintenance bypass breaker.
- 3) Turn on the external maintenance bypass breaker.
- 4) One by one turn off the battery breaker, external main input breaker, external bypass input breaker, external output breaker, the UPS power through the external maintenance bypass supply.
- 5) After the LCD screen dark, pull out the monitor module and maintenance.
- 6) When completed the maintenance, insert the power module, and tighten the screws on both sides.
- 7) One by one turn on the external output breaker, external bypass input breaker, external main input breaker and battery breaker.
- 8) After 2 minutes, the "BYP" indicator goes on of the LCD, meaning the bypass power supply normal.
- 9) Turn off the external maintenance bypass breaker.
- 10) Turn off the maintenance bypass breaker, the inverter automatically starts up, after 60 seconds, UPS transfers to normal mode.

6.4 Battery Maintenance

For the Lead-Acid maintenance free battery, when maintaining the battery according to requirements, battery life can be prolonged. The battery life is mainly determined by the following factors:

- 1) Installation. The battery should be placed in a dry and cool place with good ventilation. Avoid direct sunlight and keep away from heat source. When installing, ensure the correct connection to the batteries with same specification.
- 2) Temperature. The most suitable storage temperature is 20 °C to 25°C.
- 3) Charging/discharging current. The best charging current for the lead-acid battery is 0.1C. The maximum charging current for the battery can be 0.2C. The discharge current should be 0.05C-3C.
- 4) Charging voltage. In most of the time, the battery is in standby state. When the utility is normal, the system will charge the battery in boost mode (constant voltage with maximum limited) to full and then transfer to the state of float charge.
- 5) Discharge depth. Avoiding deep discharge, which will greatly reduce the lifetime of the battery. When the UPS runs in battery mode with light load or no load for a long time, it will cause the battery to deep discharge.
- 6) Check periodically. Observe if any abnormality of the battery, measure if the voltage of each battery is in balance. Discharge the battery periodically.

 **WARNING**

Daily inspection is very important!

Check and confirm the battery connection is tightened regularly, and make sure there is no abnormal heat generated from the battery.

 **WARNING**

If a battery has leakage or is damaged, it must be replaced, stored in a container resistant to sulfuric acid and disposed of in accordance with local regulations.

The waste lead-acid battery is a kind of hazardous waste and is one of the major contaminants controlled by the government.

Therefore, its storage, transportation, use and disposal must comply with the national or local regulations and laws about the disposal of hazardous waste and waste batteries or other standards.

According to the national laws, the waste lead-acid battery should be recycled and reused, and it is prohibited to dispose of the batteries in other ways except recycling. Throwing away the waste lead-acid batteries at will or other improper disposal methods will cause severe environmental pollution, and the person who does this will bear the corresponding legal responsibilities.

7 Product Specifications

This chapter provides the specifications of the product, including environmental characteristics mechanical characteristics and electrical characteristics.

7.1 Applicable Standards

The UPS has been designed to conform to the following European and international standards:

Table 7-1 Compliance with European and International Standards

Item	Normative
General safety requirements for UPS used in operator access	IEC62040-1-1
Electromagnetic compatibility (EMC) requirements for UPS	IEC62040-2
Method of specifying the performance and test requirements of	IEC62040-3



Note

The above-mentioned product standards incorporate relevant compliance clauses with generic IEC and EN standards for safety (IEC/EN/AS60950), electromagnetic emission and immunity (IEC/EN61000 series) and construction (IEC/EN60146 series and 60950).

7.2 Environmental Characteristics

Table 7-2 Environmental Characteristics

Item	Unit	Parameter
Acoustic noise level	dB	<65dB @ 100% load, 62dB @ 45% load
Altitude of Operation	m	≤1000, load de-rated 1% per 100m from 1000m to
Relative Humidity	%	0-95, non-condensing
Operating Temperature	°C	0-40(for UPS only), Battery life is halved for every 10°C increase above 20°C
UPS Storage	°C	-40-70

7.3 Mechanical Characteristics

Table 7-3 Mechanical Characteristics for Cabinet

Model	Uni	4-slot	6-slot	10-slot
Mechanical Dimension (W*D*H)	mm	482*816*796	482*816*1018	600*1000*2000
Weight	kg	85	130	250
color	N/A	Black		
Protection	N/A	IP20		

Table 7-4 Mechanical Characteristics for Power Module

Item	Unit	25KVA Power Module	30KVA Power Module
Mechanical Dimension, W*D*H	mm	440*678*85(2U)	
Weight	kg	20	21

7.4 Electrical Characteristics

7.4.1 Electrical Characteristics (Input Rectifier)

Table 7-5 Rectifier AC input Mains

Item	Unit	Parameter
Grid System	\	3 Phases + Neutral + PE
Rated AC Input Voltage	Vac	380/400/415(three-phase and sharing neutral with the bypass input)
Rated Frequency	Vac	50/60Hz
Input Frequency range	Hz	40~70
Input Power factor	PF	>0.99

7.4.2 Electrical Characteristics (Intermediate DC Link)

Table 7-6 Battery

Items	Unit	Parameters
Battery bus voltage	Vdc	Rated: $\pm 240V$
Quantity of	Nominal	40= [1 battery(12V)] ,240= [1 battery(2V)]

lead-acid cells		
Float charge voltage	V/cell (VRLA)	2.25V/cell (selectable from 2.2V/cell~2.35V/cell) Constant current and constant voltage charge mode
Boost charge voltage	V/cell (VRLA)	2.3V/cell (selectable from: 2.30V/cell~2.45V/cell) Constant current and constant voltage charge mode
Temperature compensation	mV/°C/cI	3.0(selectable:0~-5.0)
Final discharging voltage	V/cell (VRLA)	1.65V/cell (selectable from: 1.60V/cell~1.750V/cell) 0.6C discharge current 1.75V/cell (selectable from: 1.65V/cell~1.8V/cell) 0.15C discharge current (EOD voltage changes linearly within the set range according to discharge current)



Note

The default battery number is 40. When the actual battery in use is 32-44, ensure the actual number and the set number are the same, otherwise, batteries may be damaged.

7.4.3 Electrical Characteristics (Inverter Output)

Table 7-7 Inverter Output (To critical load)

Item	Unit	Parameter
Rated capacity	kVA	25~300
Rated AC voltage	Vac	380/400/415 (Line-Line)
Rated Frequency	Hz	50/60
Frequency Regulation	Hz	50/60Hz±0.1%

7.4.4 Electrical Characteristics (Bypass Mains Input)

Table 7-8 Bypass Mains Input

Item	KVA	25-300
Rated AC voltage	Vac	380/400/415 (three-phase four-wire and sharing neutral with the bypass)
Rated Current	A	58~720
Overload	%	110%, Long term operation 110%~125%, for 5 min 125%~150%, for 1 min >150%, 1S
Current rating of neutral cable	A	1.7×In
Rated frequency	Hz	50/60
Switch time (between bypass and inverter)	ms	Synchronized transfer: 0ms
Bypass voltage range	%	Adjustable, default -20%~+15% Up limited: +10%, +15%, +20% Down limited: -10%, -15%, -20%, -30%, -40%
Bypass frequency range	Hz	Adjustable, ±1Hz, ±3Hz, ±5Hz

7.5 Efficiency

Table 7-9 Efficiency

System Efficiency		
Normal mode (dual conversion)	%	96 (max)
Battery discharging efficiency (battery at nominal voltage 480Vdc and full-rate linear load)		
battery mode	%	96 (max)

7.6 Display and Interface

Table 7-10 Display and Interface

Display	LED + LCD Color touch screen
Interface	Standard:RS232, RS485, USB, Dry Contact Option: SNMP, AS400